

TEST EDITION



THE TEXTBOOK OF

PHYSICS

For Class **10**



Sindh Textbook Board, Jamshoro



Published by:

Gaba Sons Urdu Bazar, Karachi.



All rights are reserved with the **SINDH TEXTBOOK, BOARD, JAMSHORO**.
Prepared by **Association For Academic Quality (AFAQ)** for Sindh Text Book Board
Reviewed by **Directorate of Curriculum Assessment and Research Sindh, Jamshoro**
Prescribed by the Board of Intermediate and Secondary Education Hyderabad, Sukkur,
Larkana, Mirpurkhas, Shaheed Benaziranad and Karachi for Secondary School Examination.
Approved by the **Education and Literacy Department, Government of Sindh**.
No. SELD/CA/CW/396/2021, dated 18, July 2022.

Patron in Chief

Prrvaiz Ahmed Baloch

Chairman, Sindh Textbook Board.

Managing Director

Shahid Warsi

Association for Academic Quality (AFAQ)

Project Director

Khawaja Asif Mushtaq

Association for Academic Quality (AFAQ)

Project Manager

Rafi Mustafa

Association for Academic Quality (AFAQ)

Cheif Supervisor

Yousuf Ahmed Shaikh

Sindh Textbook Board, Jamshoro

Supervisor

Daryush Kafi

Sindh Textbook Board, Jamshoro

AUTHORS

- Dr. Imran Ali halepoto
- Dr. Murad Ali Khaskheli
- Dr. Najam Shaikh
- Dr. Mazhar Ali Abbasi
- Miss. Shams Parveen khokhar
- Mr. Abdul Majeed Tanwari

EDITORS

- Dr. Mazhar Ali Abbasi
- Mr. Noor Ahmed Khoso
- Mr. Abdul Rehman Indhar

Coordinator

- Mr. Abdul Rehman Indhar
(Assistant Subject specialist Physics)
- Mr. M. Ayoub Junejo
(Junior Subject specialist Physics)

REVIEWERS

- Dr. Mazhar Ali Abbasi
- Dr. Barkat Ali Laghari
- Mr. Sarwaruddin Jamali
- Mr. Noor Ahmed Khoso
- Mr. Zaheer Hussain Abbasi
- Ms. Rozina Channar

INTERNAL REVIEWERS

- Mr. Khalid Ahmed Abbasi
- Mr. Mian Saeed Ahmed Indhar
- Mr. Abdul Qadeer Laghari
- Mr. Mian Ayaz Ahmed Indhar
- Mr. Attaullah Shar

Technical Assistance

- Mr. M. Arslan Shafaat Gaddi

Composing Designing & Illustration

- Mr. Muhammad Arslan Chauhan

Printed at: A.S. Gaba & Printer, Karachi.



PREFACE

The century we have stepped in, is the century of Science and technology. The modern disciplines of Physics are strongly influencing not only all the branches of science but each and every aspect of human life.

To keep the students abreast with the recent knowledge; it is must that the curricula at all the levels be updated. Moreover regularly by introducing the rapid and multidirectional development taking place in all the branches of Physics.

The recent book of Physics for class X has been written in this preview and in accordance with the revised curriculum. Prepared by Ministry of Education, Govt of Pakistan, Islamabad. Reviewed by independent team of Bureau of Curriculum, Jamshoro Sindh. Keeping in view the importance of Physics, the topics have been revised and re-written according to the need of the time.

Among the new editions the introductory paragraphs, information boxes, summaries and a variety of extensive exercises have been included. Which i think will not only develop the interest but also add a lot to the utility of the book.

The Sind Textbook Board has taken great pains and incurred expenditure in publishing this book inspite to its limitations. A textbook is indeed not the last word and there is always room for improvement. While the authors have tried their level best to make the most suitable presentation, both in terms of concept and treatment. There may still have some deficiencies and omissions. Learned teachers and worthy students are therefore requested to be kind enough to point out the short comings of the text or diagrams and to communicate their suggestions and objections for the improvement of the next edition of this book.

In the end, I am thankful to Association for Academic Quality (AFAQ), our learned authors, editors and specialist of Board for their relentless service rendered for the cause of education.

Chairman
Sindh Textbook Board





CONTENTS

Sr. No	Unit Name	Page No.
Unit 10	General Waves Properties	01
Unit 11	Sound	21
Unit 12	Electromagnetic Spectrum	41
Unit 13	Geometrical Optics	57
Unit 14	Electrostatics	86
Unit 15	Current Electricity	109
Unit 16	Electromagnetism	132
Unit 17	Introductory Electronics	153
Unit 18	Information and Communication Technology ICT	179
Unit 19	Atomic Structure	198
Unit 20	Nuclear Structure	208
	Glossary	234



Unit - 10

General Wave Properties

Students Learning Outcomes (SLOs)

After learning this unit students should be able to

- Describe wave motion as illustrated by vibrations in rope, slinky spring, experiments with water waves
- Identify transverse and longitudinal waves in mechanical media, slinky springs
- Describe that waves are means of energy transfer without transfer of matter
- Distinguish between mechanical and electromagnetic waves
- Describe properties of waves such as reflection, refraction, and diffraction with the help of ripple tank
- Define the terms speed (v), frequency (f), wavelength (λ), time-period (T), amplitude, crest, trough, cycle, wavefront, compression, and rarefaction
- Solve problems by applying the relation $f = 1/T$ and $v = f\lambda$
- State the conditions necessary for an object to oscillate with SHM
- Explain SHM with simple pendulum, ball, and bowl examples
- Draw forces acting on a displaced pendulum
- Solve problems by using the formula $T = 2\pi\sqrt{l/g}$ for a simple pendulum
- Understand that damping progressively reduces the amplitude of oscillation

When the calm water surface is disturbed by a stone dropping into it, circular water ripples spread out from the point where the stone hits the water. The continuous disturbance of the water surface by the blasts of the wind caused by a helicopter hovering above creates water waves that move outwards. The disturbance on the water surface moves outwards, carrying energy, and no water, because after the waves pass, the water remains where it was before the wave was produced

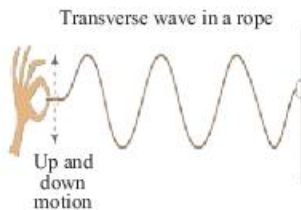

Fig: 10.1 Up and down movements produce a wave

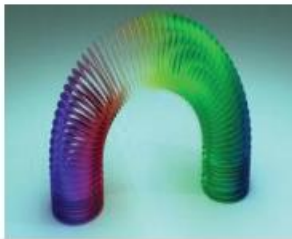

Fig: 10.2 slinky spring

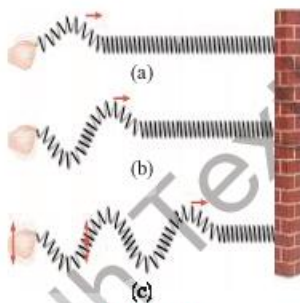

Fig: 10.3
An upward pulse moves to the right, followed by (b) A downward pulse. (c) When the end of the Slinky is moved up and down continuously, a transverse wave is produced

We experience the impacts of waves every day in our daily life. Every sound we listen to depends on sound waves. Every sight we see depends on light waves. A little wave can travel across the water in a glass, and a very large tide can travel over the sea. Sound waves, light waves, and water waves appear very different. So, what similarities do all these different forms of waves have? What, exactly, is a wave? What are the characteristics of a wave? We will study it all in detail in this unit.

10.1 Waves and nature of waves

A method transport energy from one point to another point without transfer of matter is called wave.

Formation of waves

Disturbance of medium cause of formation of wave like, we can produce waves by using a rope, slinky spring, and water waves in ripple tanks. Let us discuss them in detail.

Wave Motion by using a Rope

We can produce waves on a rope by attaching one end to a wall and continuously moving the other end up and down, as shown in figure 10.1. These up-and-down movements produce oscillations or vibrations. We can observe that the generated rope waves travel towards the wall, whereas the rope itself moves only up and down. The rope is the medium through which the waves travel or propagate.

Waves in a Slinky Spring

A slinky spring is a pre-compressed helical or coiled spring as shown in fig 10.2.

We can perform several experiments with a slinky in the laboratory to understand the phenomenon of different types of wave motion.

Attach one end of the spring with a wall. Now moving the free end of the slinky horizontally left and right continuously on the table will be able to see the coils of the spring moving left and right, whereas humps travel to the other end. (10.3) (a,b,c).



Now moving the free end of the attached wall slinky spring continuously back and forth as horizontally shown in fig 10.4. You can observe the individual coils moving forwards and backwards. Where the coils are compressed, are seen traveling from the fixed end to the other end.

In both of the above experiments, the slinky spring is said to be the medium through which the waves travel or propagate.

Water wave in (Ripple Tank)

A ripple tank is a shallow glass tank of water used to demonstrate the basic properties of waves.

It is a particular type of wave tank. The ripple tank is usually illuminated from above so that the light shines through the water to visualize the wave being produced.

In the laboratory, we can produce water waves with the ripple tank. In the ripple tank, a small vibrator moves up and down the water surface, resulting in the water particles at the surface that are in contact with the dipper being made to move up and down. This up and down motion soon spread to other parts of the water surface in the tank in the form of ripples; fig.10.5. Here the water is the medium through which the ripples travel or propagate.

Types of Wave Motion

The direction in which the displacement takes place within a wave motion affects the properties of the wave. These wave types can be illustrated using a slinky, long flexible steel coil or spring, which rests on a smooth table during use. Wave energy can be transmitted, for example, by a slinky, and for illustrations, each of the coil turns can represent a particle of the medium through which a wave is traveling.

Transverse Wave

The slinky illustrates the transverse wave in Fig. 10.5. Move the free end of the slinky up and down repeatedly. These up and down movements of the coils produce oscillations. Have you noticed that when coils move up and down, the direction of the wave motion is

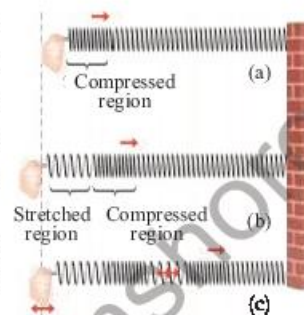

Fig: 10.4 (a)
A compressed region moves to the right, followed by (b) a stretched region. (c) When the end of the Slinky is moved back and forth continuously, a longitudinal wave is produced.

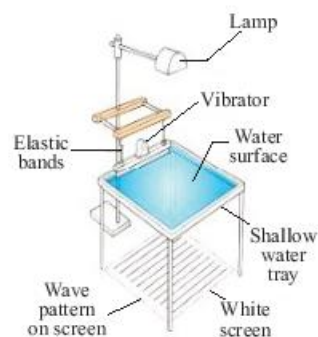

Fig: 10.5.
Schematic diagram of a ripple tank

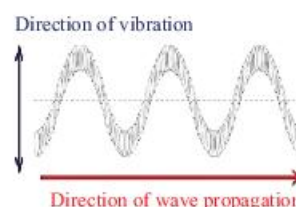

Fig: 10.6.
A transverse wave in a slinky

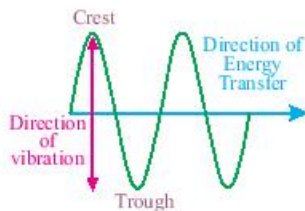

Fig: 10.7
Transverse wave



Weblinks

Encourage students to visit the below link for longitudinal waves and transverse waves.
<https://www.sciencelearn.org.nz/resources/2681-waves-and-energy-transfer>

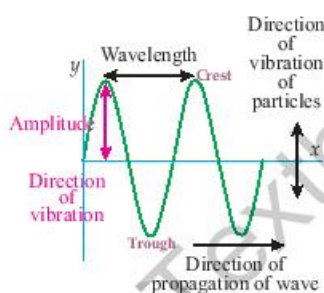

Fig: 10.8.
The transverse wave is represented by Amplitude, Crest, Trough, and wavelength spreading

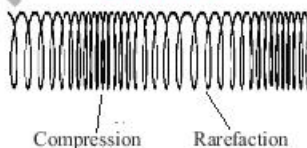

Fig: 10.9 Longitudinal Wave in a Slinky

perpendicular to the direction of oscillation? We call this type of wave is a transverse wave; Fig. 10.7.

In the light of the above experiment, transverse waves can be defined as

Transverse waves are waves that travel in a direction perpendicular to the direction of wave motion”.

Transverse wave motion can also be observed on the surface of the water in a pond or a ripple tank, vibrations in a guitar string. Another essential type of transverse wave is electromagnetic waves, e.g., light waves, microwaves, radio waves.

Amplitude is the maximum displacement moved by a point on a vibrating body from the rest or mean position.

It is the height of a crest or depth of a trough measured from the rest position as shown in fig 10.8. Its SI unit is meter (m).

Crest is a point on a surface wave where the displacement of the medium is at a maximum. OR

The positive/upper part of wave is called crest.

Trough is a point on a surface wave where the displacement of the medium is at a maximum.

Longitudinal Wave

The slinky illustrates the longitudinal wave in Fig. 10.8. Move the free end of the slinky forward and backward (i.e. push and pull) to expand and compress the slinky repeatedly. These forwards and backwards movements of the coils produce oscillations. Have you noticed that when coils move forwards and backwards, the direction of the wave motion is parallel to the direction of oscillation? We call this type of wave is a longitudinal wave.

Longitudinal waves can be defined as

“Longitudinal waves are waves that travel in a direction parallel to the direction of wave motion”.

Another common example of a longitudinal wave is sound waves.

Compression, in the longitudinal waves this is a region where turns of the coil or particles are closer together than average.



Rarefaction, in the longitudinal waves this is a region where turns of the coil or particles are further apart than average.

Waves are means of energy transfer without transfer of matter

The wave is a disturbance in a medium that transfers energy from one place to another

Waves transfer energy over a distance. Can waves move matter the entire distance? For example, a tide can travel many kilometers. The water moves up and down- a disturbance that travels in a wave, transferring energy, not matter.

Mechanical and electromagnetic waves

Difference between these waves on the basis of medium.

Mechanical waves	Electromagnetic waves
Mechanical waves are such waves that need a medium for propagation.	Electromagnetic waves are such waves that do not need a medium for propagation.
Mechanical waves are produced by vibratory motion in the respective medium.	Electromagnetic waves are produced by a changing of electric and magnetic fields.
Sound waves, water waves, and seismic waves are some examples of mechanical waves.	Radio waves, microwaves, light waves, U.V waves and infrared waves are some examples of electromagnetic waves.
Mechanical waves consist of transverse as well as longitudinal waves.	Electromagnetic waves are only comprised of a transverse wave in nature.
Mechanical waves cannot travel through the vacuum.	Electromagnetic waves travel through the vacuum at the speed of 3×10^8 m/s.
All mechanical waves travel through their media at different speeds depending upon the physical properties of the respective medium.	All electromagnetic waves can travel through transparent media at different speeds depending upon the refractive index of the respective medium.

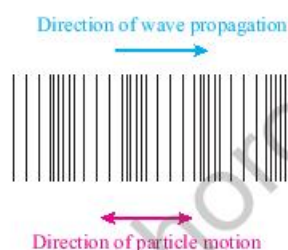

Fig: 10.10 Longitudinal Wave



Do You Know!

We can produce plane waves by using a straight dipper in a ripple tank. These waves can be seen as bright and dark lines on a screen below the tank. These bright and dark lines represent the crests and troughs of the plane waves respectively



SELF ASSESSMENT QUESTIONS:

- Q1:** Distinguish between transverse and longitudinal waves.
Q2: Wave motion transfers energy without moving matter. Justify this statement with an example.
Q3: What is the main difference between mechanical waves and electromagnetic waves?

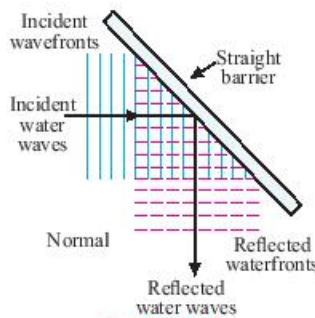

Fig: 10.11
Reflection of the water waves

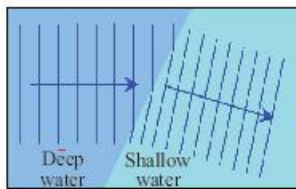

Fig: 10.12
when a barrier is placed to decrease the depth of water in a ripple tank

Water waves being slowed down in a ripple tank

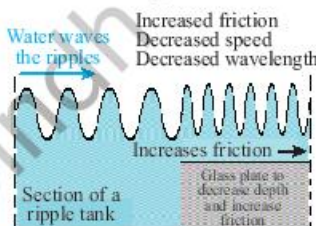

Fig: 10.13
Change in the direction of wave front and decrease in wavelength

10.2 Properties of Waves

The depth at which the dipper is placed affects the amplitude of the waves, while the frequency of vibration of the dipper corresponds to the frequency of water waves produced.

Let us demonstrate some wave properties such as reflection, refraction, and diffraction concerning the ripple tank.

Reflection of the waves

Figure 10.11 shows how one can demonstrate the reflection of the waves? When a vertical straight surface is placed in the path of the incoming waves. The incident waves are reflected from the surface at the same angle. It can be seen that the reflected waves obey the law of reflection, Example, the angle of the incident wave along the normal will be equal to the angle of the reflected wave. Hence we define the reflection of waves as:

Bouncing back of waves into same medium by striking other medium surface is called reflection.

Refraction of waves

Figure 10.12 shows how refraction of the waves can be demonstrated. When a flat piece of a block is immersed in the ripple tank, water depth becomes shallow. You will find that the wavelength of the plane waves shortens and changes direction; Fig. 10.13 as they move from the boundary between two media, deep to shallow water. However, the frequency of water waves stays the same in both waves because it is the same as the frequency of the vibrator. This result shows that the speed of a wave in water depends on water depth. Waves travel faster in deep



water than in shallow water. This effect is called refraction. Hence we can define the refraction of the waves as:
When a wave enters from a region of deep water to a region of shallow water at an angle, the wave will change its direction.

Diffraction of waves

Figure 10.14 shows when an obstruction or a straight surface with a gap in the ripple tank is placed in the path of the incoming water waves, they strike it, the waves will bend around the sides of an obstruction or spread out as they pass through a gap. This phenomenon is called diffraction.

Diffraction is only significant if the size of the gap is about the same as the wavelength of the incident wave, narrow the gap whose width is equal to the wavelength of the incoming ripples, the ripples that pass through the gap are almost circular and seem to originate from a point source situated in the gap. Wider gaps produce less diffraction. Hence we define the diffraction of waves as.

The spreading of the waves near an obstacle is called diffraction.

Waves Characteristics

The following are some terms used to describe wave motion.

Time-Period (T), is the time taken for any one point on the wave to complete one oscillation.

The SI unit of the period is second (s).

Frequency (f), is the number of complete waves produced by a source per unit of time.

Thus,

Frequency = Number of complete waves produced/ time taken

If the number of waves produced = 1

And time is taken = T Then $f = 1/T$

In general,

Frequency is also defined as the reciprocal of the period.

The SI unit of frequency is the hertz (Hz).

Wavelength (λ), is the linear distance between two successive crests or troughs in a transverse wave and two

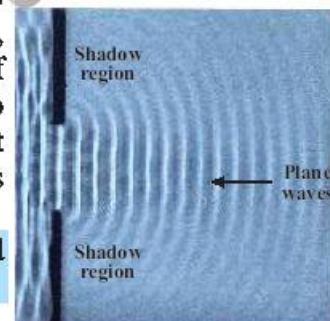
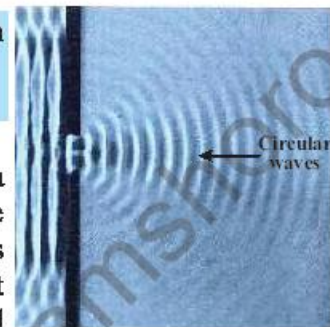

Fig: 10.14.
Diffraction of waves near an obstacle (a) Wider the gap, less spreading (b) narrow the gap, more spreading

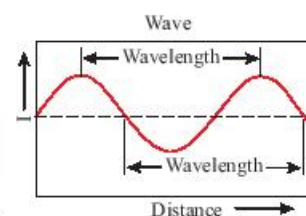

Fig: 10.15 (a)

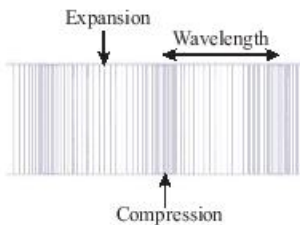

Fig: 10.15 (b)
Wavelength (λ)

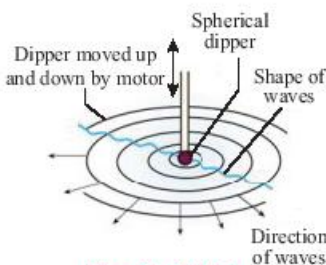

Fig: 10.16 (a)
concentric circles

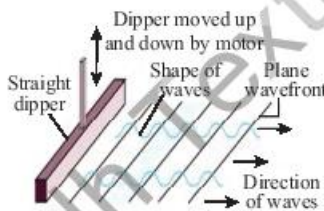
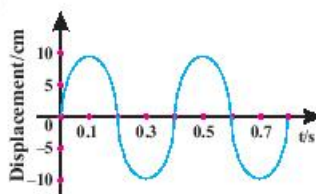

Fig: 10.16 (b)
Straight Line



successive compressions and rarefactions in a longitudinal wave. Its SI unit is meter (m).

Wave speed (v), is the speed at which a wave travels.

It is defined as the distance traveled by a given point on the wave, such as a crest in a given interval of time.

Speed = Distance traveled/time taken or

Let us consider for a wave,

Distance travelled = λ and time is taken = T , then

$$v = \frac{S}{t}$$

Hence $S = \lambda$

so $t = T$

$$v = \frac{\lambda}{T} \quad \rightarrow (i) \quad \therefore \quad \frac{1}{T} = f$$

$$v = f\lambda$$

$$S = v \times t$$

$$\lambda = v \times T \quad \rightarrow (ii)$$

The speed of wave can also be written as $V = f\lambda$

In the SI system, the wave speed is measured in m/s.

The Wavefront is an imaginary line on a wave that joins all points that are in the same phase.

A wavefront is usually drawn by joining all wave crests. There are two types of the wavefront, depending on how the waves are produced, which are concentric circles; figure 10.16. (a) and plane straight lines; figure 10.16. (b).

Figure 10.16 (a). In a ripple tank, a dipper can produce circular waves. These waves have a circular wavefront.

Figure 10.16 (b). In a ripple tank, a plane dipper can produce plane waves. These waves have a plane wavefront.

Worked Example 1

The given figure shows the displacement vs the time of a wave traveling to the right with a speed of 4 m/s.

(a) What is the time period and frequency of the wave?

(b) Calculate the wavelength of the wave?

Solution:



Step 1: Write down the known quantities and quantities to be found.

- (a) $v = 4 \text{ ms}^{-1}$
i. $T = ?$,
ii. $f = ?$
(b) $\lambda = ?$

Step 2: Write down the formula and rearrange if necessary.

- (a) (i) T , use graph, and
(ii) $f = 1/T$
(b) $v = f \times \lambda$

Step 3: Put the values and calculate

- a. (i) From the graph
 $T = 0.4 \text{ s}$
(ii) $f = 1/(0.4\text{s})$
 $= 2.5 \text{ Hz}$
b. $\lambda = 4(\text{ms}^{-1})/(2.5\text{Hz})$

Result: $= 1.6 \text{ m}$.

Worked Example 2

A fisherman notices that his boat is moving up and down regularly due to waves on the surface of the water. It takes 4.0 s for the boat to travel from the highest to the lowest point, a total distance of 3.0 m. The fisherman sees that the wave crests are spaced 8.0 m apart.

- (a) What is the period, frequency, amplitude, and wavelength of the waves?
(b) How fast are the waves moving?

Solution:

Step 1: Write down the known quantities and quantities to be found.

Moving from the highest point to the lowest point

Time taken = 4.0 s

Distance = 3.0 m

Distance between the crests = 8.0 m

- (a)
i. $T = ?$
ii. $f = ?$
iii. $A = ?$
iv. $\lambda = ?$



Weblinks

Encourage students to visit below link for displacement time graphs
https://www.youtube.com/watch?v=TG2Y2MDx-zE&ab_channel=FuseSchool-GlobalEducation



Weblinks

Encourage students to visit below link for period, frequency and amplitude
https://www.youtube.com/watch?v=TG2Y2MDx-zE&ab_channel=FuseSchool-GlobalEducation



Weblinks

Encourage students to visit below link for
Waves Ripple
Tank Interference

https://www.youtube.com/watch?v=0c0gvy_OOKc&ab_channel=launchSCIENCE



Weblinks

Encourage students to visit below link for
Waves - Frequency, Speed,
and Wavelength

https://www.youtube.com/watch?v=4yfXp1jNBn8&ab_channel=JonWhite

(b) $v=?$

Step 2: Write down the formula and rearrange if necessary.

a.

i. T is the time taken to move from the highest point to the lowest point and from the lowest point to the highest point.

ii. $f = \frac{1}{T}$

iii. A is the one-half of displacement from the highest point to the lowest point

iv. λ is the distance between the two consecutive crests

b. $v = f \times \lambda$

Step 3: Put the values and calculate

a.

i. $T = 2(4.0s)$
 $= 8.0s$

ii. $f = \frac{1}{80s}$
 $= 0.125 \text{ Hz.}$

iii. $A = \frac{1}{2}(3.0m)$
 $= 1.5m.$

iv. $\lambda = 8.0 \text{ m.}$

b. $v = (0.125\text{Hz})(8.0\text{m})$

Result: $= 1.0 \text{ m/s.}$

Thus, the period, frequency, amplitude, and wavelength of the waves are 8.0s, 0.125Hz, 1.5m, and 8.0m respectively. The wave is moving at the speed of 1.0 m/s.

SELF-ASSESSMENT QUESTIONS:

Q1: How spherical wavefronts are produced in the ripple tank?

Q2: What is the difference between displacement and amplitude of the wave?

Q3: Drive the relation between wave speed and frequency.



10.3 Simple Harmonic Motion (SHM)

Periodic Motion

A motion repeating itself in an equal time interval is referred to as periodic or oscillatory motion.

Simple Harmonic Motion

An object in such a periodic motion oscillates about an equilibrium position due to a restoring force or a restoring torque. Such force or torque will return the system to its equilibrium position. This type of motion is called Simple Harmonic Motion that is defined as:

When an object oscillates about a fixed position (mean position) its acceleration is directly proportional to its displacement from the mean position and is always directed towards the mean position as shown in fig 10.17, its motion is called SHM.

$$a \propto -x$$

$$a = -kx \quad \text{where } k \text{ is spring constant}$$

Many phenomena include electromagnetic waves, alternating current circuits, musical instruments, bridges, and molecular motion that executes the simple harmonic motion.

10.4 Simple pendulum

Forces acting on a displaced pendulum

When the bob of the pendulum is displaced at a small angle ' θ ' to an extreme position; Fig. 10.18. The forces that act upon it are as given underneath:

- i. Tension 'T' along the direction of the string, and
- ii. Weight $W = mg$, acting vertically downwards.

The weight is further resolved into its components $mg \sin \theta$ and $mg \cos \theta$.

Motion of a simple pendulum and SHM

Let us think of an experiment to prove that a simple oscillating pendulum executes Simple Harmonic Motion. Old-fashioned clocks, a child's swing, and a fishing sinker are pendulum examples. A pendulum's restoring force is proportional to its displacement for minor displacements under 15 degrees. Simple pendulum has simple harmonic motion.

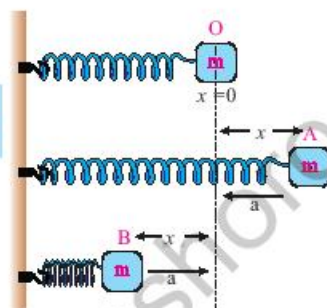

Fig: 10.17
Simple harmonic motion

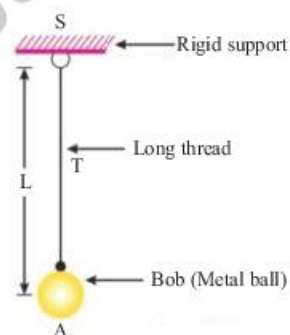

Fig: 10.18. Forces acting on the bob in simple pendulum



Do You Know!

The restoring force is a force which acts to bring a body to its equilibrium position.



A simple pendulum consists of a small metallic bob of mass 'm' suspended from a light inextensible string of length 'l' fixed at its upper end.

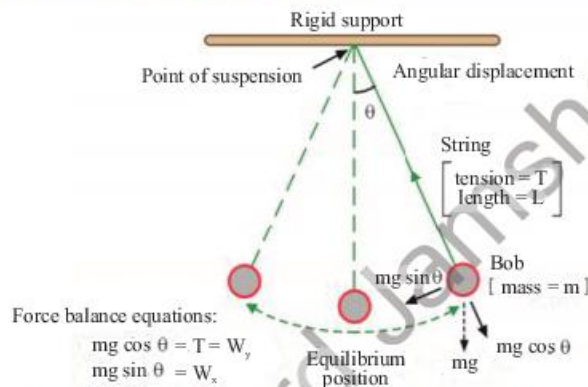

Fig: 10.19. Forces acting on the bob in simple pendulum

At the mean position O, a pendulum is in its equilibrium position. If no external force were applied, the bob of a pendulum would naturally settle here as illustrated in fig 10.19.

The curve path s is the distance the bob of a pendulum travels. The weight mg consists of the components $mg \cos \theta$ along the string and $mg \sin \theta$ perpendicular to the arc. For each given string, the component $mg \cos \theta$ perpendicular to the string is exactly cancelled by the tension in the string. The resulting net force, which is directed back toward the equilibrium point, is tangential to the arc and equals $mg \sin \theta$.

Simple pendulum period is affected by length and gravity acceleration. The period is independent of mass and amplitude.

For the simple pendulum executing SHM, we have the following formula for its period;

$$T = 2\pi \sqrt{\frac{l}{g}}$$

This formula shows that the period 'T' of a simple pendulum depends upon its length 'l' and acceleration due to gravity 'g' over that place. The period of the pendulum is independent of its mass and its amplitude.



Weblinks

Encourage students to visit below link for Simple pendulum stimulation

✓ <https://www.myphysicslab.com/pendulum/pendulum-en.html>

✓ https://phet.colorado.edu/sims/html/pendulum-lab/latest/pendulum-lab_en.html



Ball and bowl system and SHM

Let us examine that the motion of a ball placed in a bowl executes simple harmonic motion. When the ball is placed at the mean position 'O' as shown in figure 10.20, that is, at the center of the bowl. In this position, the net force acting on the ball is zero. Hence there is no motion.

Now, what if we displace the ball to an extreme position 'A' and then release it? The ball starts moving towards the mean position 'O' due to the restoring force caused by its weight component. At position 'O' the ball gets maximum speed and due to inertia, it moves towards opposite extreme position 'B' with the restoring force that acts towards the mean position, the speed of the ball starts to decrease. The ball stops for a while at 'B' and then again moves towards the mean position 'O'. This ball's to and fro motion continues about the mean position 'O'. This result shows that the acceleration of the ball is directed towards 'O'. Hence, the ball's to and fro motion about a mean position placed in a bowl is also an example of simple harmonic motion.

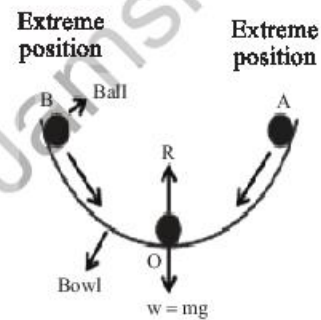

Fig: 10.20.
The motion of a ball in the bowl executing Simple Harmonic Motion

Worked Example 3

Find the period and frequency of a simple pendulum 1.0 m long at a location where $g = 9.8 \text{ m s}^{-2}$.

Solution:

Step 1: Write down the known quantities and quantities to be found.

$$L = 1.0 \text{ m}$$

$$g = 9.8 \text{ m/s}^2.$$

$$\pi \cong \frac{22}{7} \cong 3.141 \text{ and } \pi^2 \cong 9.86$$

i. $T = ?$

ii. $f = ?$

Step 2: Write down the formula and rearrange if necessary.

$$i. \quad T = 2\pi\sqrt{\frac{L}{g}}$$

$$ii. \quad f = 1/T$$

Step 3: Put the values and calculate

$$i. \quad T = 2 \times 3.14 \times \sqrt{1.0(\text{m}) / 9.8(\text{m/s}^2)}$$

$$T = 2.01 \text{ s}$$



Weblinks

Encourage students to visit below link for Pendulum clock invention, oscillation and periodic motion

https://www.youtube.com/watch?v=0c0gvy_OOKc&ab_channel=launchSCIENCE

$$\begin{aligned} \text{ii. } f &= 1/2.01 \text{ s} \\ &= 0.50 \text{ Hz} \end{aligned}$$

Result: The period of the pendulum is 2.01s and its frequency is 0.50 Hz.

Worked Example 4

Pendulum clocks with a pendulum measuring out the passing of a second. How long of a pendulum is required to have a period of 1 second? $g = 9.8 \text{ m/s}^2$.

Solution:

Step 1: Write down the known quantities and quantities to be found.

$$\begin{aligned} L &= ? \\ T &= 1.0 \text{ s} \\ g &= 9.8 \text{ m/s}^2 \\ \pi &\cong \frac{22}{7} \cong 3.141 \end{aligned}$$

Step 2: Write down the formula and rearrange if necessary.

$$T = 2\pi \sqrt{\frac{L}{g}}$$

Square both the sides

$$T^2 = 4\pi^2 \frac{L}{g}$$

Multiply both the sides by g

$$T^2 g = 4\pi^2 L$$

Divide each side by $4\pi^2$

$$L = \frac{T^2 g}{4\pi^2}$$

Step 3: Put the values and calculate

$$L = \frac{(1\text{s})^2 (9.8\text{m/s}^2)}{4\pi^2}$$

$$L = \frac{9.8\text{m}}{4\pi^2} \quad \therefore \quad \pi \cong \frac{22}{7} \cong 3.141$$

$$L = 0.25\text{m} \quad \therefore \quad \pi^2 \cong 9.86$$

Result: The length of a pendulum should be 0.25 m.



SELF ASSESSMENT QUESTIONS:

- Q1:** Calculate the frequency of seconds pendulum?
Q2: Which component of force (weight) is responsible for the oscillatory motion of a simple pendulum?
Q3: At what position acceleration of the simple oscillatory pendulum is maximum, and why?
Q4: The normal reaction of the bowl on the ball is in the upward direction. Why is it not moving in that direction?
Q5: Where is the ball in the bowl system moving fastest, slowest?

10.5. Damped Oscillation

The oscillating system, can not be assumed to have a fixed amplitude unless energy is provided to them. The resistive or damped forces progressively reduce the amplitude of the oscillation.

For example, A knock against a table causes the table to vibrate. This reverberation also fades away often after completing many hundreds of vibrations.

An oscillating system in which friction has an effect is a damped system.

If a simple harmonic motion is subjected to frictional forces, the amplitude of freely oscillating objects progressively decreases. The friction not only affects the amplitude but also slightly reduces the frequency. An oscillation that fades away over time is called damped oscillation; Fig. 10.21, 10.22.

The oscillations of a system in the presence of some resistive forces are damped oscillations.

SELF ASSESSMENT QUESTIONS:

- Q1:** What will happen if there is no damping in an oscillating drum skin?

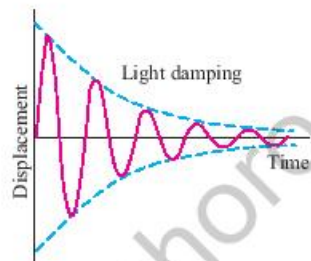

Fig: 10.21.
Variation of amplitude with the time of damping system

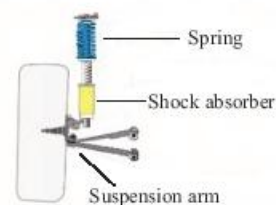

Fig: 10.22.
Shock absorber

Do You Know!

The practical application of damped motion is shock absorbers in automobiles. A shock absorber consists of a piston that moves through a liquid such as oil. The upper part of the shock absorber is firmly connected to the body of the automobile, when travels over a bump, the automobile may vibrate violently. The shock absorbers dampen these vibrations and convert their mechanical energy into the thermal energy of the oil.



SUMMARY

- Up-and-down movements in the rope produce oscillations or vibrations.
- A slinky is a pre-compressed helical or coiled spring.
- A **ripple tank** is a glass tank of water used to demonstrate the basic properties of waves.
- The particle movement is at right angles to the direction of the wave motion is a transverse wave.
- A transverse wave is comprised of crest and trough.
- The particle movement is in the same direction as the direction of wave motion, a longitudinal wave.
- A longitudinal wave is comprised of compression and rarefaction.
- The wave is a disturbance that transfers energy from one place to another.
- Any substance that a wave can propagate through it is known as a medium.
- Waves that transfer energy through matter are known as mechanical waves.
- All mechanical waves travel through their media at different speeds depending upon the elasticity and inertial properties of the respective medium.
- Waves that transfer energy without the material medium are known as electromagnetic waves.
- Ripple tank experiments demonstrate that water waves can be reflected, refracted, and diffracted.
- When a wave enters from a region of deep water to a shallow, its wavelength and speed decrease.
- The bending of waves around obstacles or sharp edges is called the diffraction of waves.
- When an object oscillates about a fixed position its acceleration is directly proportional to its displacement and is directed towards the mean position, its motion is called SHM.
- A simple pendulum consists of a small metallic bob suspended from a light and inextensible string fixed at its upper end.
- The period of a simple pendulum depends upon its length and acceleration due to gravity over that place.
- An oscillating system in which friction has an effect is a damped system. The amplitude of freely oscillating objects progressively decreases.



CONCEPT MAP

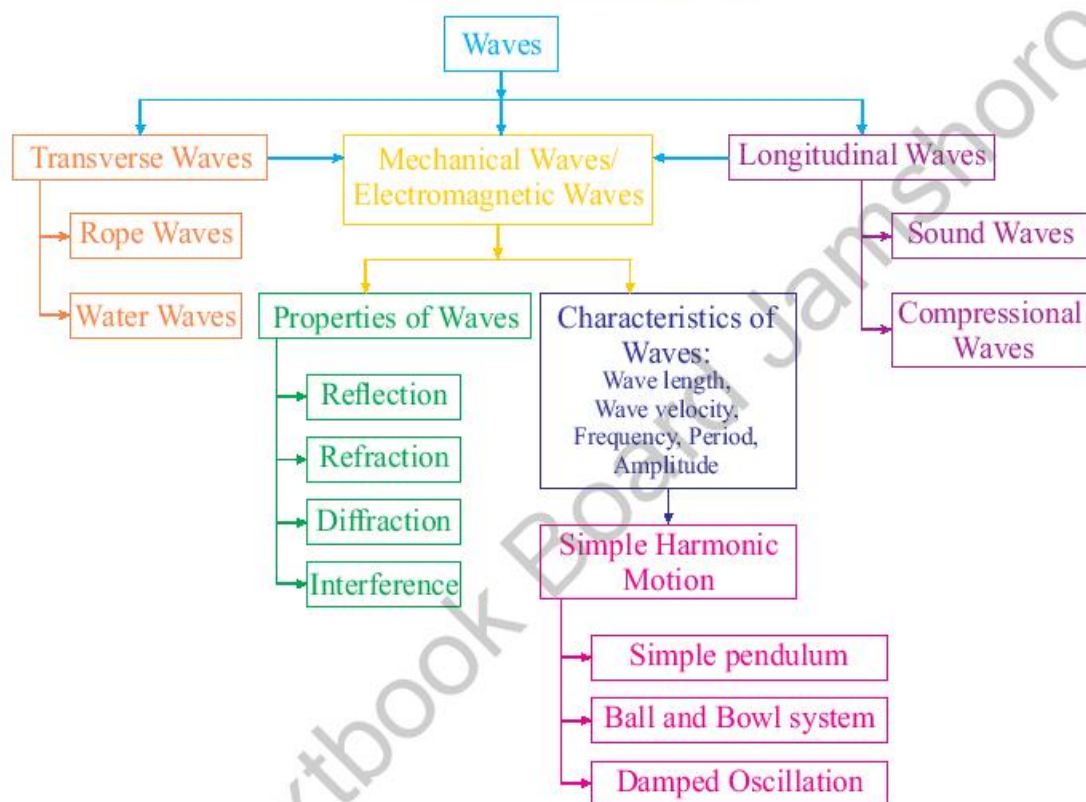

Section (A) Multiple Choice Questions (MCQs)

1. A girl throws a small stone into a lake. Waves spread out from where the stone hits the water and travel to the bank of the lake. She notices that ten waves reach the side of the pond in a time of 5.0s. What is the frequency of the waves?
- a) 0.50Hz b) 15Hz
c) 2.0Hz d) 50Hz



2. Water waves can be used to show reflection, refraction, and diffraction. For each of these, which row shows whether or not the speed of the water waves changes?

	Reflection	Refraction	Diffraction
a)	Yes	yes	Yes
b)	Yes	No	yes
c)	No	yes	no
d)	No	no	no

3. The diagrams show water waves that move more slowly after passing into shallow water. Which diagram shows what happens to the waves?

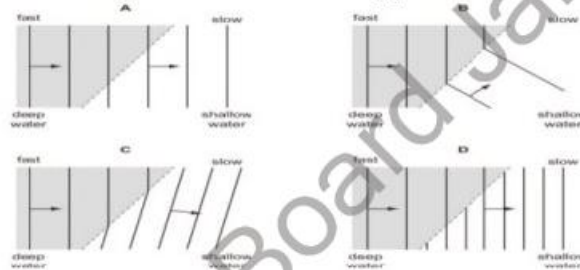

4. The diagram shows a water wave approaching a barrier with a gap.

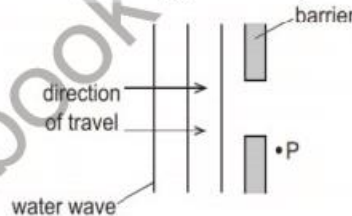

The wave reaches point P. What is the name of the effect that causes the wave to reach point P?

- a) Diffraction b) Dispersion
c) reflection d) Refraction
5. Water waves pass from deep into the shallow region then refracted. The characteristics of wave which will remains constant is:
- a) Direction b) Frequency
c) Speed d) Wavelength.
6. Which is not a characteristic of wave?
- a) An amplitude b) Period
c) Mass d) Velocity
7. When an oscillating object is in simple harmonic motion, its maximum speed occurs when the object is at its



- a) Highest point. b) Lowest point
c) Equilibrium point d) Extreme point
8. In an oscillating pendulum, the bob accelerates from its extreme position due to
a) Inertia b) Tension in the string
c) Wind d) Gravitational force
9. In the ball and bowl system, the mean position is at
a) The earth b) Floor of the bowl
c) Center of bowl d) Extreme position
10. Oscillations are damped due to the presence of
a) Linear motion b) Restoring force
c) Frictional force d) Mechanical force

Section (B) Structured Questions

- Define the term transverse wave.
- Define the term longitudinal wave.
- a) Write a short note on the mechanical wave.
b) How can you say that mechanical waves are also material waves?
- Waves are the means of energy transfer without matter. Justify this statement with the help of everyday life examples.
- a) Define the following terms of a wave:
i) amplitude ii) period
iii) frequency iv) wavelength
b) Derive the formula of wave speed, $v = f \lambda$.
- a) What is a ripple tank, and explain its working?
b) Define the wavefront?
- Reference an experiment to explain the refraction of waves concerning the ripple tank.
- What is the phenomenon of diffraction?
- a) What is simple harmonic motion?
b) What are the necessary conditions for a body to execute simple harmonic motion?
- a) With the help of a diagram, explain SHM in the pendulum.
b) The period of simple pendulum executing the formula gives SHM

$$T = 2\pi \sqrt{\frac{L}{g}}$$

What will be the effect of the period if there is an increase in its

- i) length ii) mass.
11. a) With the help of a diagram, explain SHM in the ball and bowl system.



b) Why is the motion of a ball in the bowl executing SHM is maximum at its equilibrium position?

12. a) What are damped oscillations?
 b) How does damping progressively reduce the amplitude of oscillation?
 c) A boy is swinging in the swing. Explain, why its amplitude reduces progressively with time.

Section (C) Numericals

- What is the wavelength of a radio wave broadcasted by a radio station with a frequency of 1300 kHz?
 Where $1\text{K} = 10^3$, and the speed of the radio-wave is $3 \times 10^8 \text{ ms}^{-1}$. **(230.76m)**
- The waves moving in the pond have a wavelength of 1.6 m, and a frequency of 0.80 Hz. Calculate the speed of these water waves. **(1.28ms⁻¹)**
- If 50 waves pass through a point in the rope in 10 seconds, what are the frequency and the period of the wave? If its wavelength is 8 cm, calculate the wave speed.
 Explain the type of wave produced. **(5Hz, 0.2s, 0.4ms⁻¹)**
- A slinky has produced a longitudinal wave. The wave travels at a speed of 40 cm/s and the frequency of the wave is 20 Hz. What is the minimum separation between the consecutive compressions? **(0.02m)**
- Suppose a student is generating waves in a slinky. The student's hand makes one complete forth and back oscillation in 0.40 s. The wavelength in the slinky is 0.60m. For this wave, determine
 - Period and frequency
 - Wave speed **(0.40s, 2.5Hz, 1.5ms⁻¹)**
- If 80 compressions pass through a point in spring in 20 seconds. Calculate the frequency and the period? If two consecutive compressions are 8 cm apart, calculate the wave speed. **(4Hz, 0.25s, 0.32ms⁻¹)**
- Waves on a swimming pool propagate at 0.90 m/s. If you splash the water at one end of the pool, observe the wave go to the opposite end, reflect, and return in 30.0 s. How far away is the other end of the pool? **(0.033Hz, 27.27m)**
- A simple oscillating pendulum has a length of 80.0 cm. Calculate its
 - Period
 - Frequency
 When $g = 9.8 \text{ m s}^{-2}$ **(1.794s, 0.557Hz)**

Unit - 11

Sound

SHAH JAHAN MASJID THATTA

Students Learning Outcomes (SLOs)

After learning this unit students should be able to

- Describe the production of sound by vibrating sources.
- Describe the longitudinal nature of sound waves and describe compression and rarefaction.
- Explain why a medium is required to transmit sound waves and describe an experiment to demonstrate this.
- Describe a direct method for the determination of the speed of sound in air and make the necessary calculation.
- State the order of magnitude of the speeds of sound in air, liquids, and solids.
- Describe the factors which affect the speed of sound (temperature, humidity, etc.)
- Describe how the shape of a sound wave as demonstrated by an oscilloscope is affected by the quality of the sound wave
- Explain that noise is a nuisance.
- Describe how the reflection of sound may produce an echo.
- Define ultrasound.
- Describe how ultrasound techniques are used in medical and industry

Shah Jahan Masjid Thatta has 93 domes (the largest number in Pakistan) and 33 arches. It does not have a single minaret. When the loudness exceeds 100 decibels, a person speaking on one end of the masjid can be heard on the other end.

The quietest room in the world (Anechoic Chambers)

Specially designed rooms that are mostly utilized for technology testing.

In 2015, Microsoft built the quietest place on earth. But while it may sound like a sanctuary of meditative bliss, few can stand being in the room for an elongated amount of time.

After a number of minutes, you will begin to hear your own heartbeat. Stick it out a little longer, and you will hear your own blood flowing and bones grinding.



Weblinks

Encourage students to visit below link for Sound waves experiment

https://www.youtube.com/watch?v=2mlBh5d1IUY&ab_channel=FuseSchool-GlobalEducation

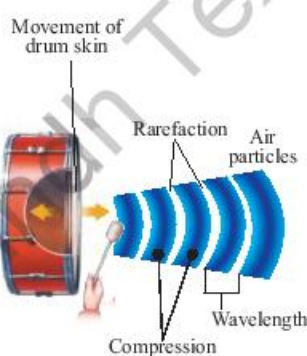

Fig: 11.1
Vibration of drum skin

Do you know that elephants can hear a storm from a distance of 200 km away? Also, communicate over great distances using sound that we cannot hear. Some animals such as bats, use sound echoes to find their way and catch prey. Scientists use ultrasound (echoes) to detect objects underwater or even to produce images of the organs inside of the human body. How are they able to do this? The physics behind it will explain the phenomenon.

11.1 Sound waves

Sound waves are mechanical, longitudinal waves comprising compressions and rarefactions.

Production of sound by vibrating sources

When you hit the skin of a drum, it starts vibrating, and it moves back and forth very quickly. These vibrations squeeze and stretch the air in its front and disrupt the surrounding molecules. This series of squeezes and stretches accordingly produce compressions and rarefactions which travel through the air. It produces sound waves.

Sound is produced by vibrating sources placed in a medium.

A vibrating object in the medium causes of alternating compressions and rarefactions that carry the sound further away through the medium.

Sound is the form of energy related to the vibrating motion of molecules.

This energy travels from one point to another as a wave. For example, a guitar produces a musical note when the string vibrates.

Longitudinal nature of sound waves

A sound is a mechanical longitudinal wave. The direction of vibration of air molecules is parallel to wave motion, similar to the longitudinal waves produced when a slinky spring is vibrated parallel to its direction of motion, as we studied in the previous unit page no 4.

Let us consider the drum how can produce longitudinal sound waves by disturbing the molecules surrounding it; Fig. 11.1. Note the compressions (C) and rarefactions (R) produced by vibrating drum skin.



Now, we can consider that the compressions and rarefactions of sound waves are due to a slight change in the air pressure.

Compressions are regions where air pressure is slightly higher than surrounding air pressure and

Rarefactions are regions where air pressure is slightly lower than the surrounding air pressure.

This rising and falling of air pressure take place continuously as long as the drum produces the sound. Thus, we can illustrate the region where the sound travels through air as in figure 11.2.

Electric bell jar Experiment

Sound is a mechanical wave that needs a material medium such as gases, liquids, solids to propagate due to the vibratory motion of particles of the medium that transport sound waves in the form of energy from one point to another. Sound cannot travel through a vacuum, demonstrated by the following experiment.

Take an electric bell and an airtight glass bell jar and then suspend the electric bell inside the jar. Connect the bell jar to a vacuum pump; Fig. 11.3. When you switch on the electric bell, you can hear the sound of the bell coming from inside air and glass material. Now start the vacuum pump. As the air in the jar is gradually pumped out, the sound becomes fainter, although the same current is passing through the bell and hammer that strikes the gong. After a while, you will hear the faintest sound, when there is less air. What happens when the air is completely removed? Will you still be able to hear the sound of the bell?

The electric bell still produces the sound, but now we cannot hear it. This is because sound waves always need a medium to propagate sound energy. In the bell jar, it was a vacuum hence sound waves cannot travel.

This experiment makes sure that the bell does not touch glass and that the connecting wires used are thin. This prevents the sound energy from being transmitted through the glass and wires to the outside of the jar as the hammer vibrates vigorously.

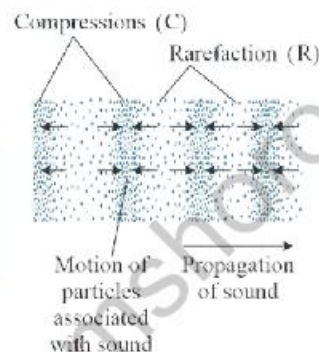

Fig: 11.2. The vibrating drum skin produce alternating regions with high density and low density of air molecules

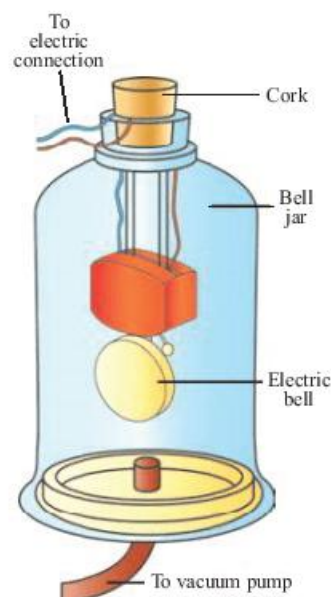

Fig: 11.3 Bell jar experiment showing sound cannot travel in a vacuum



SELF-ASSESSMENT QUESTIONS:

- Q1:** Why pressure is greater at compression region of longitudinal waves.
- Q2:** Why can we not hear the explosives sound produced in the Sun?
- Q3:** Can sound travel through solids and liquids?

11.2 Speed of sound

A direct method for the determination of the speed of sound in air

As we know, sound travels quite fast, but it is still possible to measure its speed in the air by direct methods. To do this, we have to measure the time it takes for sound to travel a measured distance. However, how do we measure the speed of sound? The following experiment demonstrates the direct method.



Do You Know!

Trundle wheel is a mechanical device which is used to measure distance and it is also known as Surveyor wheel

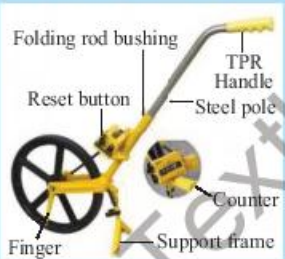

Experiments to Determine the Speed of Sound

- There are several experiments that can be carried out to determine the speed of sound
- Two methods are described below
- The apparatus for each experiment is given in **bold**

Method 1: Measuring Sound Between Two Points

Measuring the speed of sound directly between two points

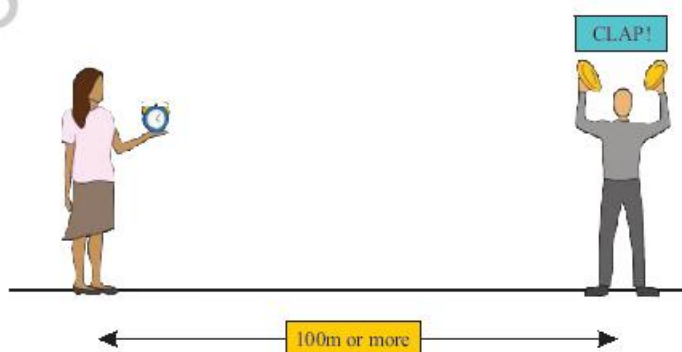

1. Two people stand a distance of around 100 m apart
2. The distance between them is measured using a **trundle wheel**
3. One person has **two wooden blocks**, which they bang together above their head



4. A second person with a stopwatch starts watch when he hears one of the claps and ends timing after 20 claps.
5. This is then repeated several times and an average value is taken for the time.
6. The speed of sound can then be calculated using the equation:

$$\text{Speed of sound} = \frac{\text{Distance traveled by sound}}{\text{Time taken}}$$

Method 2: Using Echoes

Measuring the speed of sound using echoes

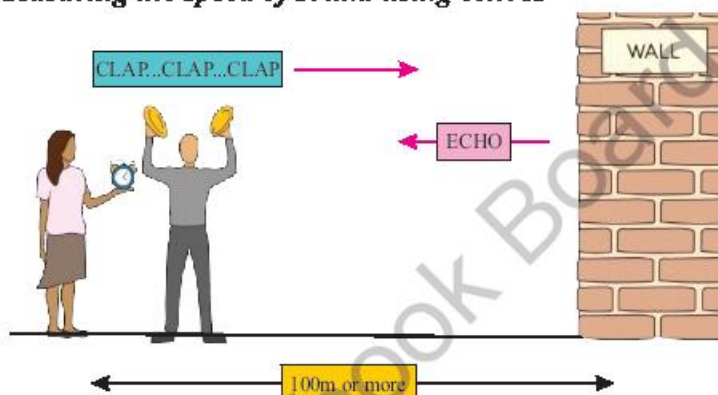

1. A person stands about 50 m away from a wall (or cliff) using a **trundle wheel** to measure this distance
2. The person claps two **wooden blocks** together and listens for the echo
3. The person then starts to clap the blocks together repeatedly, in rhythm with the echoes
4. A second person has a **stopwatch** and starts timing when they hear one of the claps and stops timing 20 claps later
5. The process is then repeated and an average time calculated
6. The distance travelled by the sound between each clap and echo will be (2×50) m
7. The total distance travelled by sound during the 20 claps will be $(20 \times 2 \times 50)$ m



Weblinks

Encourage students to visit below link for measuring speed of sound by using echo

https://www.youtube.com/watch?v=1wrD4JLgblc&ab_channel=VTPhysics



Weblinks

Encourage students to visit below link for echo method determination of speed of sound

https://www.youtube.com/watch?v=Hb5z2d6G5jU&ab_channel=CBSE



8. The speed of sound can be calculated from this distance and the time using the equation:

$$\text{Speed of sound} = \frac{2 \times \text{Distance to the wall}}{\text{Time taken}}$$

Speed of sound in solids, liquids, and gases.

Sound waves are mechanical waves. Any medium that contains particles can transmit sound. The speed of sound is not the same in all mediums. Sound waves travel at different speeds in different mediums. Remember that the speed of sound depends on the properties such as temperature, pressure and density of the medium through which it travels. Sound moves faster in solid because the molecules/ particles of solid are very close to each other, as compare to liquid and gases.

The speed at which a sound wave travels depends upon the medium and state of the medium (steel, water, air). The rate of sound wave travel decreases when we go from solid to the gaseous state. The speeds of sound at 25°C in various media are listed in Table 11.1.

The speed of sound is defined as the distance which a point on a wave, such as a compression or a rarefaction, travels per unit of time.

We know,

$$\text{Speed } v = \text{distance} / \text{time}$$

$$v = \frac{\lambda}{T}$$

Where λ is the wavelength of the sound wave. It is the distance traveled by the sound wave in one time period (T) of the wave. Thus,

$$v = \lambda f (\because 1/T = f)$$

$$\text{or } v = \lambda f$$

The speed of sound remains almost the same for all frequencies in a given medium under the same physical conditions.



Weblinks

Encourage students to visit below link for speed of sound through solid, liquid and gases

https://www.youtube.com/watch?v=bSA4gfiahNw&ab_channel=Clapp



Weblinks

Encourage students to visit below link for the speed, distance and time rules and how to apply them to real life

https://www.youtube.com/watch?v=7fz-4BUDyqg&ab_channel=XcelerateMath



Table 11.1 Speed of sound in different media at 25 °C

Speed of sound in different media at 25 °C		
State	Substance	Speed in m/s
Solids	Aluminum	6420
	Nickel	6040
	Stainless Steel	5960
	Brass	4700
	Copper	2270
	Glass (Pyrex)	3980
Liquids	Water (Sea)	1531
	Water (distilled)	1498
	Ethanol	1207
	Methanol	1103
Gases	Hydrogen	1284
	Helium	965
	Air	340
	Oxygen	316
	Sulfur dioxide	213



Weblinks

Encourage students to visit below link for how sound travels across different medium

https://www.youtube.com/watch?v=AxNdr0Bcx20&ab_channel=KnowledgePlatform

Factors that affect the speed of sound

The speed of sound is affected by a variety of factors. Two of the factors affecting the speed of sound in the air are given in detail below.

Effect of Temperature

Temperature is also a condition that affects the speed of sound. Heat is a form of energy that depends upon the kinetic energy of molecules. Molecules of the medium at higher temperatures have more energy. Thus, they can vibrate at a higher rate. As the molecules vibrate faster, sound waves can travel more quickly. The speed of sound at room temperature (25°C) in the air is 346 meters per second. It is faster than 331 meters per second, which is the speed of sound in air at (0°C).

The formula to find the speed of sound at temperature T in the air is given as follows:

$$v = 331 \times \sqrt{\frac{T}{273K}}$$

Here v is the speed of sound, and T is the absolute temperature of the air. This formula shows that the speed of sound in air is directly proportional to the square root of the

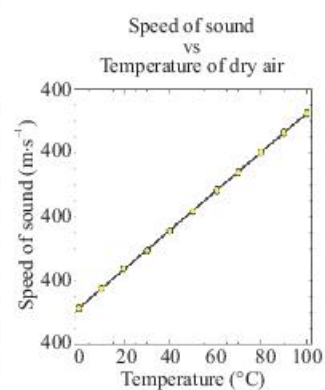

Fig: 11.4 Graphical representations for speed of sound against temperature



Weblinks

Encourage students to visit below link for why moist air is less dense than dry air

https://www.youtube.com/watch?v=-75kAiV6y-s&ab_channel=How-ToWeather

absolute temperature; Fig. 11.4. Thus, the temperature of the air increases, so the speed will also increase.

Effect of humidity:

Humidity also affects the speed of sound in the air. The effect of water vapor on the speed of sound is **minimum** than that of dry air. The presence of moisture in air replaces oxygen and nitrogen gases that reduce the density of air because the molecular mass of water vapors (Molecular Mass = 18) is less than that of oxygen (Molecular Mass = 32) and nitrogen (Molecular Mass = 28) gases since the speed of sound in gases are inversely related to the square root of its

$$\text{density} \left(v \propto \frac{1}{\sqrt{\rho}} \right).$$

Thus, humidity increases, the density of the air decreases and sound travels faster.

Worked Example 1

A sound wave has a frequency of 6 kHz and wave length 25 cm. How long will it take to travel 1.5 km?

Solution:

Step 1: Write down the known quantities and quantities to be found.

$$f = 6 \text{ kHz} = 6000 \text{ Hz}$$

$$\lambda = 25 \text{ cm} = 0.25 \text{ m}$$

$$d = 1.5 \text{ km} = 1500 \text{ m}$$

$$t = ?$$

Step 2: Write down the formula and rearrange if necessary.

$$v = \lambda f, \text{ and}$$

$$d = v \times t$$

$$t = d/v$$

Step 3: Put the values and calculate.

$$v = (0.25 \text{ m}) \times (6000 \text{ Hz})$$

$$v = 1500 \text{ m/s, and}$$

$$t = d/v$$

$$t = 1500 \text{ m} / 1500 \text{ ms}^{-1}$$

$$t = 1 \text{ s.}$$

Result: Time = $t = 1.0$ second



Worked Example 2

Calculate the speed of sound in air at 30°C? Given that speed of sound at 0°C is 331 m/s.

Solution:

Step 1: Write down the known quantities and quantities to be found.

$$T = 30^\circ\text{C} = 30 + 273\text{K}$$

$$T = 303\text{K}$$

Step 2: Write down the formula and rearrange if necessary.

$$v = 331 \times \sqrt{T/273}$$

Step 3: Put the values and calculate.

$$v = 331 \times \sqrt{303\text{K}/273\text{K}}$$

$$v = 331 \times \sqrt{1.1099}$$

$$v = 331 \times 1.05352$$

$$v = 348.7\text{ m/s.}$$

Result: Speed of sound $V = 348.7\text{m/s}$

SELF-ASSESSMENT QUESTIONS:

Q1: Can any object produce a sound without any vibrations in it?

Q2: How can the pressure affect the speed of the sound in the air?

Q3: A sound wave traveling in a solid pass into the air. What will happen to the speed of a sound wave when it enters the air? Explain.

11.3 Seeing sounds

When we listen to a musical song on a radio, we can distinguish between the notes of various instruments such as a recorder and a violin being played in the song. It is due to the varying quality of these notes. Figure 11.5 shows the waveform of the sound produced by a violin, oboe, and French horn. If the loudness and the pitch of these three sounds are the same, then how their waveforms are different. How do their qualities differ? How can they be distinguished from one another? To understand this, let us consider figure 11.5. Most of the sounds like our voice, chirping of birds, and notes from different musical instruments produce

Do You Know!

Timbre is what makes one instrument or voice sound different from other

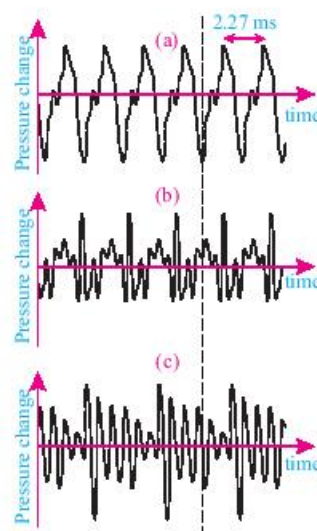

Fig: 11.5
wavefronts produced by
(a) violin
(b) oboe and
(c) French horn



Fig: 11.6
Formation of a note on
the oscilloscope

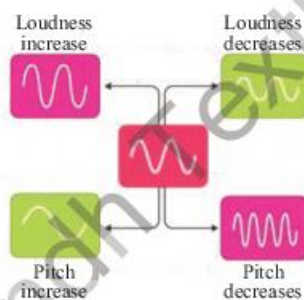

Fig: 11.7
Pitch and loudness
Loudness of the sound
is dependent on the
amplitude of sound.
Pitch the pitch of the
sound is dependent on
the frequency of sound.

varying waveforms. These waveforms are produced by blending different frequencies.

Quality: It is defined as the characteristic of sound by which we can distinguish between two sounds of the same loudness and pitch.

To understand this, let us consider a fundamental frequency and other two frequencies; if we combine these waves on an oscilloscope, we will get a single waveform with two overtones in it; Fig. 11.6.

loudness: It refers to the ability to distinguish between a loud and a quiet sound.

Pitch: It is the quality of sound that distinguishes between a shrill and a flat sound.

Loudness and pitch depends upon amplitude and frequency respectively as shown in figure 11.7.

Sound intensity or acoustic intensity: It is defined as the power carried by sound waves per unit area in a direction perpendicular to that area.

The SI unit of intensity, which includes sound intensity, is the watt per square meter (W/m^2).

SELF-ASSESSMENT QUESTIONS:

- Q1:** What characteristic determines the quality of the sound?
Q2: If two sounds from different sources have the same frequency and loudness. Can you distinguish the sounds?

11.4 Noise pollution

In our daily life, we enjoy hearing sounds of different qualities. We hear the sound produced by musical instruments such as the recorder, guitar, violin, drum. The sound of these instruments has a tone with characteristics such as controlled pitch and quality that have a pleasant effect on our hearing sensation.

The sounds that are pleasant to our ears are called musical sounds.

However, some sounds have unpleasant effects on our ears, such as the sound of motor vehicles, the slamming of a door, and the sounds of machinery.



Sound which has an unpleasant effect on our ears is called noise.

Noise corresponds to irregular and sudden vibrations generated by some sources. Noise is pollution, has become a significant issue of concern all over the world. *Noise* is an unpleasant sound that is harmful not only to human health but also to other species. Transportation equipment and heavy machinery are the primary sources. For example, the noise of the machinery in industrial areas, loud vehicle horns, hooters, and alarms. The excessive noise level has harmful effects on human health as they can cause conditions such as stress and disturb concentration. Over time, hearing loss, sleeping disorder, aggression, hypertension, high-stress levels can occur.

A safe level of noise depends on two factors: the noise level; and the duration of exposure to the noise. The noise level recommended in most countries is usually 85-90 dB over an eight-hour workday. Noise pollution can be reduced to an acceptable level by replacing the noisy machinery with environment-friendly machinery and equipment, placing sound-reducing barriers, or using hearing protection devices.

Table 11.2 Noise levels in decibels

Noise	Noise levels in decibels (dB)
Personnel stereo, very loud	150
Damage to hearing	140
Rock concert	110
Sound of drill machine, 3 meters away	90
Busy road	70
Normal conversation	60
Whispering	30
Threshold of hearing	0

SELF ASSESSMENT QUESTIONS:

Q1: What types of sounds have pleasant effects on our hearing sensations?

Q2: How can we reduce noise pollution?



Do You Know!

The decibel (dB) unit is usually used for measuring the relative loudness of sounds detectable by human hearing. The term *bel* is derived from the name of Alexander Graham Bell, Inventor of the telephone. Decibel is the smaller unit of bell.



Do You Know!

Irregular repeating sound waves create noise, while regular repeating waves produce musical notes.

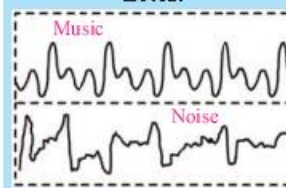

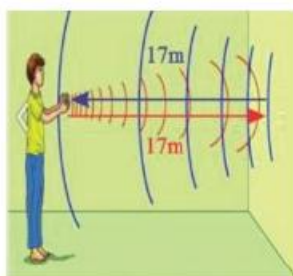

Fig: 11.8. A boy standing in front of a wall produces an echo



Do You Know!

The sound sensitivity persists in our brain for about 0.1 s. To hear a clear echo, the time interval between the produced original sounds and the reflected one must be at least 0.1s



Do You Know!

Echolocation is a technique to determine the location of objects using echo sound. Some incredibly blind people have also developed the ability to echolocate by actively creating sounds: for example, by lightly stomping their feet, tapping their canes, snapping their fingers. People trained to orient by echolocation can interpret the sound waves reflected by nearby objects, accurately identifying their location.

Reflection of sound or an echo.

If we stand in front of a suitable reflecting object such as a tall building or a mountain and shout or clap our hands once, we will hear the exact sound repeat after a short moment; Fig.11.8.

The repetition of the sound after reflection is known as an echo.

If we take the speed of sound 340 m/s at a temperature of 20 °C in air, the sound travels to the obstruction and reaches back to the listener on reflection after 0.1s. Hence, the total distance covered by the sound from the point of production to the reflecting surface and back should be at least

$$\begin{aligned} \text{distance} &= \text{speed} \times \text{time} \\ d &= 340 \text{ m/s} \times 0.1 \text{ s} \\ d &= 34 \text{ m.} \end{aligned}$$

Thus, for hearing clear echoes, the minimum distance of the obstruction from the source of sound should be half of this distance, that is, 17 m.

Worked Example 3

A boy clapped his hands near a wall and heard the echo after 1.6 s. What is the distance of the wall from the boy if the speed of the sound, v is taken as 340 ms^{-1} ?

Solution:

Step 1: Write down the known quantities and quantities to be found.

$$\begin{aligned} t &= 1.6 \text{ s} \\ v &= 340 \text{ m s}^{-1} \\ d &=? \end{aligned}$$

Step 2: Write down the formula and rearrange if necessary.

$$d = v \times t$$

Step 3: Put the values and calculate.

$$\begin{aligned} d &= (340 \text{ m s}^{-1}) \times (1.6 \text{ s}) \\ d &= 544 \text{ m} \end{aligned}$$

In 1.6s sound has to travel twice the distance, towards the wall and then back to the boy.

Result: the distance between the wall and the boy will be

$$\begin{aligned} d &= 544 \text{ m}/2 \\ d &= 272 \text{ m.} \end{aligned}$$



11.5 Ultrasound

We know that a vibrating body produces sound in a medium. The normal human ear is not able to detect sounds of all frequencies. If we could hear infrasound, we would hear the vibrations of a pendulum. Likewise, we hear the vibrations of the wings of a mosquito. Not only infrasonic of very low frequencies, but our ears also cannot hear very high frequency sounds known as ultrasound.

The sound with frequencies above the upper limit of the human range of audibility is known as **Ultrasound**.

Generally, we classify ultrasound as those having frequencies above 20,000 Hz.

The range of frequencies of sound that a person can hear is called the range of audibility or the **audible frequency range**.

Sound with frequencies below the lower limit of the human range of audibility is known as **infrasonic**.

Different animals can hear different ranges of frequencies as shown in figure no. 11.9 and as well as in table 11.3.

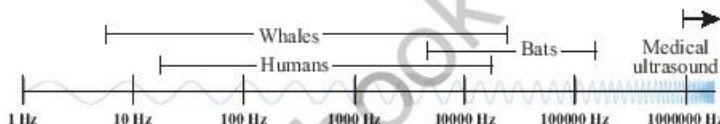

Fig: 11.9

The spectrum of sound frequencies for humans and other animals

Table 11.3 The audible frequency ranges of living organisms

Species	Frequency (hertz)	
	The lower limit of the audible frequency	The upper limit of the audible frequency
Elephants	16	12000
Human	20	20000
Horses	31	40000
Dogs	40	40000
Whales and dolphins	70	15000
Cats	100	32000
Locust	100	50000
Seals and sea lions	200	55000
Bats	1000	150000



Do You Know!

Different people have a different range of audibility. It also decreases with age as people grow older. Their hearing senses become less sensitive to higher frequencies. For the average human ear, the lower limit of audible frequency is 20 Hz, and the upper limit is 20000 Hz. In other words, our ears only respond to frequencies above 20 Hz and below 20000 Hz.



Fig: 11.10.
Ultrasound cleaning

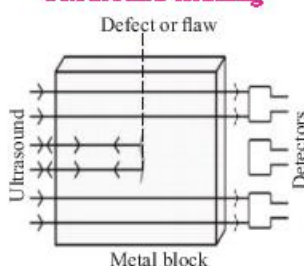

Fig: 11.11. A defect is detected by the ultrasound in metallic block

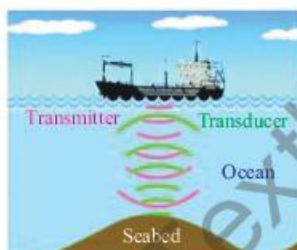

Fig: 11.12. Measuring the depth of seabed in the ocean by using ultrasound

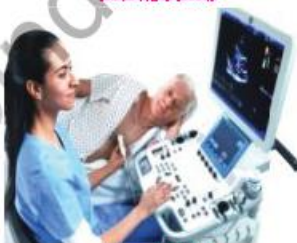

Fig: 11.13.
Echocardiography to see the heart functions

Applications of ultrasound techniques in industry and medicine

Ultrasounds, high-frequency sound waves can propagate along well-defined straight paths, Ultrasounds are used extensively in industries and for medical diagnostic (imaging) purposes.

Cleansing

Ultrasound is commonly used to clean many objects even in hard-to-reach places, including jewelry, dental and surgical instruments, musical instruments. In this process, objects to be cleaned are placed in a cleaning solution, and ultrasonic waves are sent into the solution. Due to its high frequency, dust, grease, and contamination particles detached and dropped. The objects thus get thoroughly cleansed.

Quality control

Ultrasound has higher penetrating power due to its very high frequency. Thus, ultrasounds are also used to detect cracks, cavities, and flaws in metal and concrete blocks. These invisible cracks or cavities inside the blocks reduce the strength of the structure. Ultrasonic waves pass through the metal block, and detectors are used to detect the transmitted waves. If there is any defect, the ultrasound will be reflected, indicating the presence of the defect; Fig. 11.11.

Sound navigation and ranging (SONAR)

SONAR is extensively used in marine applications. Due to their high frequencies, ultrasound waves can travel greater distances. In this method, the transmitter sends out ultrasound pulses and measures the time it takes for the pulses to reflect off a distant object and return to the source or transducer. The position of that object can be identified, and its movement can be tracked. This technique is used to measure the depth of sea beds, locate and track submarines at sea, and locate explosive mines below the surface of the water; Fig. 11.12.

Echocardiography

Echocardiography is a painless and non-invasive medical imaging procedure. A transmitter sends out pulses of very high frequency. The transducer is positioned on the chest at specific locations and angles, the pulses move across the skin



and other body tissues to the heart tissues, where the pulses bounce or echo of the heart structures; Fig. 11.13. These pulses are then transmitted to a computer to create moving images of the heart walls and valves. The image produced is called an echocardiogram.

Ultrasonography

It is a technique that uses an instrument ultrasound scanner. This scanner uses high-frequency sound waves to obtain images of the internal organs of the human body and to examine the fetus during pregnancy. A sonologist visualize the organs of the patient, such as the liver, gall bladder, uterus, kidney, etc. It helps the doctor to identify abnormalities, such as stones in the gall bladder and kidney or tumors and abnormalities in different organs. In this technique, the sound waves penetrate the body and hit a boundary between tissues, e.g., between fluid and soft tissue, bone and soft tissue, and get reflected from an area where their tissue density changes; Fig. 11.14. The instrument calculates the distance from the probe to the tissue or organ boundaries using the speed of sound in tissue and the time of the return of each echo. These pulses are then converted into electrical signals used to create two-dimensional images of the organ.

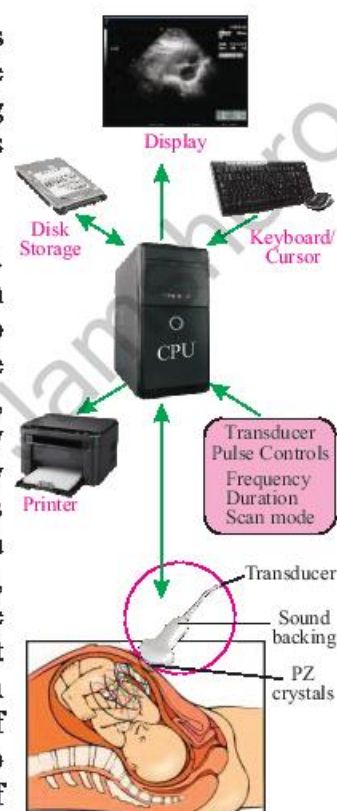

Fig: 11.14. The schematic diagram of the ultrasound scan machine

SELF-ASSESSMENT QUESTIONS:

Q1: Which one has a higher speed sound or light?

Q2: Is it possible to produce an echo in a room of length 10m?



Do You Know!

RADAR

is used in Air traffic control and vehicle speed detection

SONAR

is used to measure ocean floor and locate submarines.

LiDAR

is used in autonomous driving forestry, canopy heights, biomass measurement and LiDAR speed guns.



SUMMARY

- Sound is the form of energy related to the motion of vibrating molecules.
- Sound is a longitudinal wave; the direction of vibration of molecules is parallel to the direction of wave motion.
- Sound wave is comprised of successive compressions and rarefactions in the medium.
- Compressions are regions where air pressure is slightly higher than surrounding air pressure.
- Rarefactions are regions where air pressure is slightly lower than the surrounding air pressure.
- Sound needs a material medium to pass through energy.
- Sound cannot travel through a vacuum.
- Sound waves travel at different speeds in different mediums depending on their properties.
- The speed of sound is faster in solid materials and slower in liquids or gases.
- Temperature affects the speed of sound in air sound travels faster when the temperature of the medium rises.
- Humidity slightly affects the speed of sound in air, and sound travels faster when the humidity of the air rises.
- Quality is the characteristic of sound by which we can distinguish between two sounds of the same loudness and pitch.
- Sounds that are pleasant to our hearing sensations are called musical sounds.
- Sounds that are unpleasant to our hearing sensations are called noises.
- The high noise level has harmful effects on human health.
- The range of audibility is the range of sound frequencies that a person can hear.
- The normal human ear, the lower limit of audible frequency is 20 Hz, and the upper limit is 20K Hz.
- Ultrasound is the sound with frequencies above the upper limit of the human range of audibility.
- The echo is the reflection of the sound after reflection from an obstacle.
- In industry, ultrasounds can be used to detect cracks, cavities, and flaws in metal and concrete blocks.
- Sound navigation and ranging (SONAR) is used to measure the depth of sea beds, locate and track submarines at sea, and locate explosive mines below the surface of the water.
- Echocardiography uses ultrasound to produce the motional images of the heart and its valves.
- Ultrasonography uses ultrasound to scan soft organs and tissues.



CONCEPT MAP

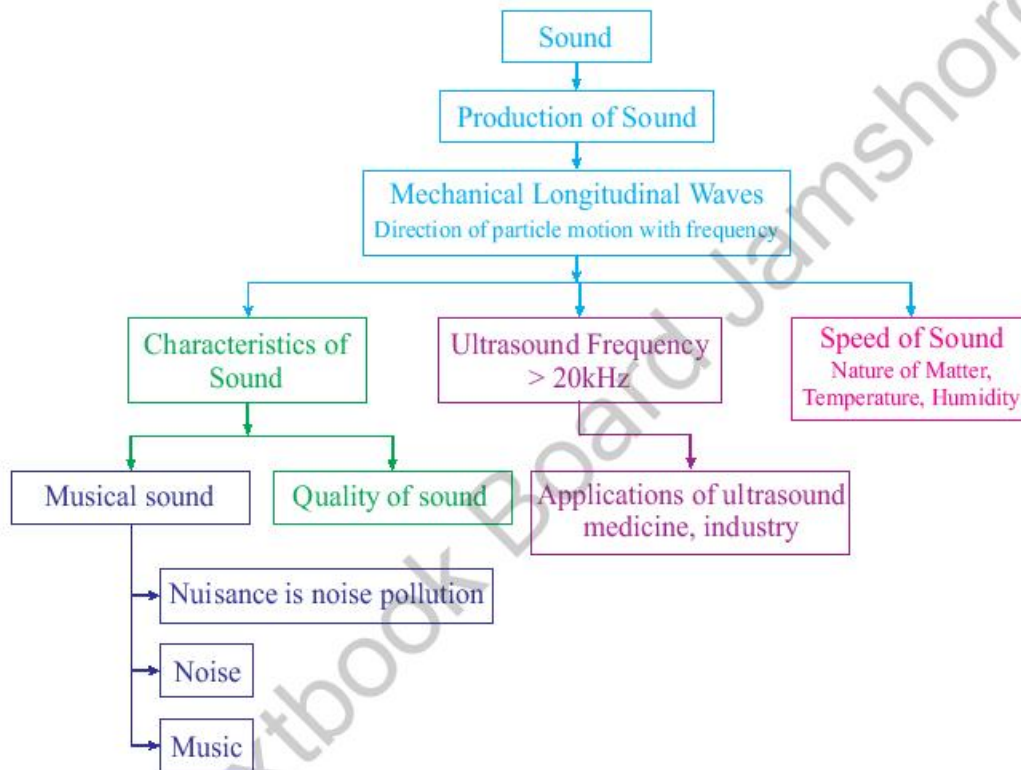

**Section (A) Multiple Choice Questions (MCQs)**

Choose the correct answer from the following choices:

1. Sound is a form of:
a) Electrical energy b) Mechanical energy
c) Thermal energy d) Chemical energy
2. Audible frequencies range that a normal human ear can detect is:
a) 10 Hz and 10 kHz b) 20 Hz and 20 kHz
c) 25 Hz and 25 kHz d) 30 Hz and 30 kHz
3. The approximate value of the speed of sound in air at 0°C temperature is:
a) 332 m / s b) 34 m / s
c) 17 m / s d) 680 m / s
4. Sound travel faster in solid as compare to gases because of:
a) Gas molecules are packed loosely.
b) Sound does not travel faster through a solid than a gas.
c) Solid molecules are packed tightly.
d) Gas molecules move faster.
5. The two factors that affect the speed of sound in air are:
a) Humidity and volume of the air
b) Temperature and mass of the air
c) Volume and mass of the air
d) Temperature and humidity of the air
6. The separation between two consecutive compressions of the sound wave is called:
a) Time period b) Amplitude
c) Frequency d) Wavelength
7. The order of speed of the sound in different mediums from faster to slowest is
a) Gas → Liquid → Solid b) Liquid → Solid → Gas
c) Solid → Liquid → Gas d) Gas → Solid → Liquid
8. Ultrasound has several uses in medicine and industry. Which one has use of ultrasound?
a) Absorption b) Pre-natal scanning
c) Dispersion d) Measuring humidity of air
9. The causes of the echo is:
a) Absorption b) Dispersion
c) Reflection d) Refraction



10. Which type of wave cannot travel through a vacuum?
- a) Sound waves
 - b) Infra-red radiation
 - c) Microwaves
 - d) X-rays

Section (B) Structured Questions

1. a) How is the sound produced?
b) With the help of a diagram, describe how compressions and rarefactions are produced in the air near a source of the sound.
2. a) Why are sound waves referred to as mechanical waves?
b) Sound requires a material medium for its propagation. Cite an experiment to prove this statement.
3. a) Distinguish between musical sound and noise.
b) Explain how noise is harmful to humans?
4. a) Define the quality or timbre of the sound.
b) Is it possible that two or more waves from different musical instruments combine to form a single wave?
5. a) Why is the speed of the sound greater in solids than in liquids or gases?
b) Explain the effect of the following factors on the speed of sound in the air.
i. Temperature
ii. Humidity
6. a) Define echo.
b) Explain the working and application of a sonar.
c) How can defects in a metal block be detected using ultrasound? Explain with the help of a diagram.
7. a) Define the following terms
i. Infrasonic
ii. The audible frequency range of hearing
iii. Ultrasound
b) How is ultrasound used for cleaning?
c) Explain two applications of ultrasound that are used in hospitals for medical imaging.



Section (C) Numericals

1. Calculate the speed of sound in air at 50°C ? Given that speed of sound at 0°C is 331m/s . **(360.0 ms^{-1})**
2. A person has an audible range from 20 Hz to 20 kHz. What are the distinguishing wavelengths of sound waves in air corresponding to these two frequencies? Take the speed of sound in air as 340 m s^{-1} . **(58.8mm and 58.82m)**
3. A ship uses ultrasonic pulses to measure the depth of the submarine beneath the ship. A sound pulsing is transmitted into the sea, and the echo from the sea-bed is received after 40 ms. The speed of sound in seawater is 1480 m / s . Calculate the deepness of the submarine. **(29.6 = 30m)**
4. At night, bats emit pulses of sound to detect their prey. The speed of sound in air is 340 m / s .

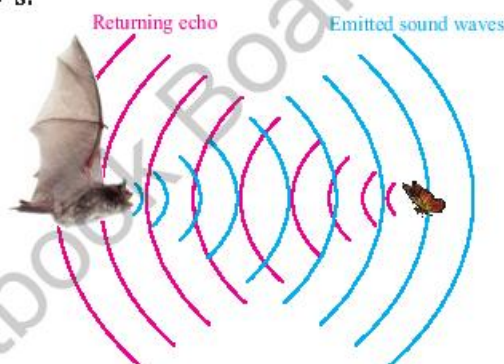

- (i) A bat emits a pulse of the sound of wavelength 0.0080 m . Calculate the frequency of the sound. **(42.5Hz)**
- (ii) The pulse of sound hits its prey and is reflected in the bat. The bat receives the pulse 0.10 s after it is emitted. Calculate the distance traveled by the pulse of sound during this time. **(17m)**
- (iii) Calculate the distance of prey from the bat. **(8.5m)**

Unit - 12

Electromagnetic Spectrum

Radio

Students' Learning Outcomes (SLOs)

After learning this unit, students should be able to

- Describe the dispersion of light as illustrated by the action on the light of a glass prism
- State the colors of the spectrum and explain how the colors are related to frequency/wavelength.
- Describe the behavior of light when passing through water droplets.
- State that all electromagnetic waves travel with the same high speed in air and state the magnitude of that speed.
- Describe the main components of the electromagnetic spectrum.
- Discuss the role of the following: (i) radio waves – radio and television communications, (ii) microwaves – satellite television and telephone, (iii) infra-red – household electrical appliances, television remote controller, and intruder alarms, (iv) light – optical fibers in medical uses and telephone, (v) ultra-violet – sunbeds, fluorescent tubes, and sterilization, (vi) X -rays – hospital use in medical imaging and killing cancerous cells, and engineering applications such as detecting cracks in metal, (vii) gamma rays – medical treatment in killing cancerous cells, and engineering applications such as detecting cracks in metal.

May 16,
the International Day
of Light

UNESCO celebrates the role of light in science, education. It plays an essential role in our lives. It is the origin of life through photosynthesis on its most fundamental level. The light has led us to alternative energy sources and many other discoveries that have shaped our understanding of the Universe. For centuries, the study of light and its properties has revolutionized every science discipline, from Ibn Al Haytham to Einstein. From gamma rays to radio waves, the spectrum of light provides understandings both far-ranging and near.



Do You Know!

The prism is a triangular transparent block of glass or plastic. It is a solid structure having three rectangular and two triangular surfaces.

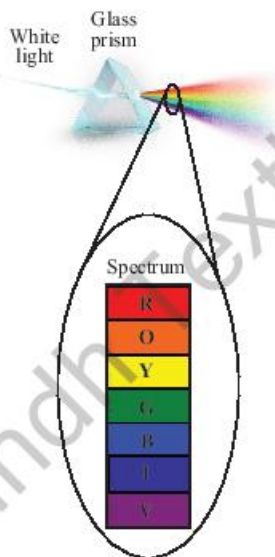
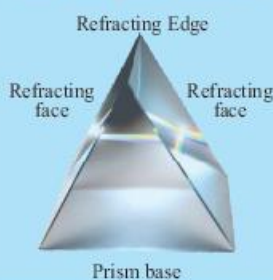

Fig: 12.1
Dispersion of white light by a glass prism

We live in a technologically advanced world, where more and more electronic appliances are going wireless. We use mobile phones, laptops, and even mobile televisions. It seems like these cordless appliance scans detect and read information from our surroundings, and we can also communicate and share digital information through electronic media. Where does all this information come from? How does this information travel through in air or a vacuum? We will try to understand all this in detail.

12.1 Dispersion of light

Have you ever seen the rainbow? What the physics behind this phenomenon is; Let us learn it by using a glass prism. Suppose a narrow beam of white light entering from the air is passed through a prism of the denser medium. A prism refracts the light at both the refracting surfaces, and it produces a range of colors called a spectrum.

Splitting white light into its constituent colors when it passes through a glass prism is called dispersion of white light.

White light is not a single color but a mixture of all the spectrum colors. The prism refracts each individual color differently depending on their refractive index.

The spectrum of White light

When a narrow beam of white light splits, the color sequence produced in the spectrum is indicated by the acronym V I B G Y O R, which stands for Violet, Indigo, Blue, Green, Yellow, Orange, and Red, as shown in figure 12.1. The speed and direction of white light vary depending on the wavelength. The red color has a maximum speed in the glass prism, with the slightest deviation. In contrast, the violet color has minimum speed, which with most deviation because color has its own refracted path in the air and becomes distinct on the spectrum.

The color pattern produced in the dispersion is called a spectrum of light.

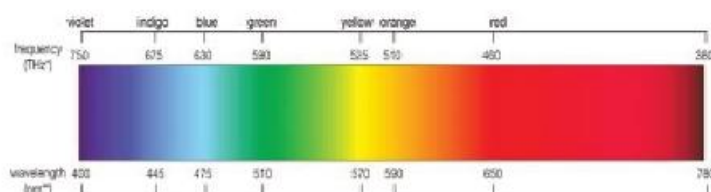

Figure: 12.2 Spectrum of visible light with corresponding wavelengths and their frequencies of each color

Table: 12.1.

Index of Refraction in crown glass at Various Wavelengths. The table shows different colors have different wavelengths so, as the refractive index

Color	Wavelength/ nm	Refractive Index
Red	650	1.332
Orange	625	1.333
Yellow	575	1.334
Green	525	1.336
Blue	450	1.340
Indigo	425	1.342
Violet	400	1.344

Dispersion of light through water droplets

The rainbow is one of nature's most beautiful creations. When a rainbow appears, it serves as an excellent demonstration of light dispersion and further evidence that visible light has a spectrum of wavelengths, each of which is associated with a distinct color. At an angle of approximately 40 degrees above ground level, you must look into an area of atmosphere with suspended droplets of water, or even a light mist, in order to see a rainbow in the sky. Every droplet of water acts as a tiny prism, dispersing and reflecting light to your eye. When you look at the sky, droplets emit wavelengths of light associated with a color. There are several ways sun rays can enter through a drop. The bending toward and away from the normal is a defining characteristic of each and every path. The path of light as it enters the droplet, internally reflects, and then refracts out of the droplet is an important consideration when discussing rainbows. Figure 12.3 shows the complete process of dispersion of light through water droplet.

Do You Know!

The red color is used in the traffic signals. Red light has the highest wavelength of all the colors, and the air molecules least scatter it. So, it can travel the longest distance and penetrate through rain, mist, and fog. This is why red is being used in traffic signals to make the stop signal visible from a far distance.

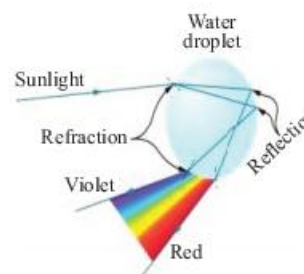

Fig: 12.3.
The dispersion by a water droplet



Do You Know!

When you listen to the radio, watch TV or make food in a microwave oven, you use electromagnetic waves.



Do You Know!

Light-year is the distance that light travels in one year. Light travels through interstellar space at 300,000 kilometers per second.

1 year = 365 days
 = 365 × 24 days
 = 365 × 24 × 60 minutes
 = 365 × 24 × 60 × 60 seconds
 = 31536000 seconds
 1 light year = Velocity × Time
 = 300000 km/s × 31536000 s
 = 9.46 × 10¹² m.

Speed of electromagnetic waves

Electromagnetic waves are radiated out when charged particles oscillate. For example, vibrating atoms in a hot, glowing bulb filament emit infrared and visible light in the house. An oscillating electric current sends out radio waves from a radio station. The other types of EM radiation that make up the electromagnetic spectrum are microwaves, ultraviolet light, X-rays, and gamma rays that radiate out from their respective sources.

Electromagnetic waves are transverse waves. It is electric and magnetic fields that are oscillating, not material. Thus, they can travel through a vacuum or space.

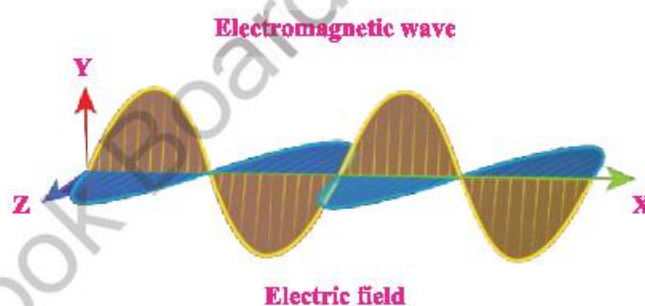

Like all other waves, it obeys the equation

$$\text{Speed} = \text{frequency} \times \text{wavelength}$$

$$c = f \times \lambda$$

All electromagnetic waves travel through the space or vacuum at the same speed of 300000 kilometers per sec or $3 \times 10^8 \text{ m.s}^{-1}$.

Worked Example 1

Ruby laser emits the beam of red light having a wavelength of 694.3 nm. Calculate its frequency.

Solution:

Step 1: Write down the known quantities and quantities to be found.

$$\lambda = 694.3 \text{ nm} = 694.3 \times 10^{-9} \text{ m}$$

$$\lambda = 6.93 \times 10^{-7} \text{ m}$$

$f = ?$ and we know that

$$c = 3 \times 10^8 \text{ m.s}^{-1}$$



Step 2: Write down the formula and rearrange if necessary

$$v = \lambda f, \text{ and}$$

$$f = c/\lambda$$

Step 3: Put the values and calculate.

Speed = wavelength \times frequency

$$f = \frac{c}{\lambda}$$

or $f = (3 \times 10^8 \text{ m/s}) / (6.943 \times 10^{-7} \text{ m})$

Result: $f = 4.32 \times 10^{14} \text{ Hz}$

The frequency produced by the laser is $4.32 \times 10^{14} \text{ Hz}$.

SELF-ASSESSMENT QUESTIONS :

Q1: A ray of blue light deviates more than a ray of red when passing through a prism. Explain why?

Q2: Give the sequence of colors produced in the dispersion through a prism.

Q3: X-rays have a higher frequency than radio waves. What is their speed in space?

12.2 Characteristics of electromagnetic waves

Some of the common characteristics of electromagnetic waves are given as under;

1. Electromagnetic waves are transverse waves in nature. They are composed of varying electric and magnetic fields that oscillate perpendicularly. The direction of wave motion is perpendicular to both electric and magnetic fields.
2. It can not carry electric charge.
3. It can travel through space, traveling at the speed of $c = 3 \times 10^8 \text{ m.s}^{-1}$.
4. It will travel through a transparent medium; however, they will slow down when traveling through a denser medium like water or glass.
5. It obeys the laws of reflection, refraction, and diffraction.
6. Its frequencies depend only on the source that produces the wave. Thus, frequencies do not change when it travel from one medium to another (air to glass).



Do You Know!

Electromagnetic waves can travel through a transparent medium at different speeds according to their respective refractive index.



Do You Know!

Ultraviolet radiation from the electromagnetic spectrum can not be seen, but it tans our skins and causes some substances to become fluorescent.



Main components of the electromagnetic spectrum

The electromagnetic spectrum has a wide range of frequencies, wavelengths, and energies. The spectrum covers the range of all electromagnetic radiation and consists of many sub-ranges that are generally referred to as components, such as visible light or ultraviolet radiation. There are no precise accepted boundaries between these continuous portions, so the ranges may tend to overlap. The electromagnetic spectrum is the entire distribution of electromagnetic waves according to their frequencies or wavelengths.



Do You Know!

The electromagnetic waves of higher frequencies, such as X-rays or gamma rays, are more hazardous due to their higher energies (or higher frequencies)

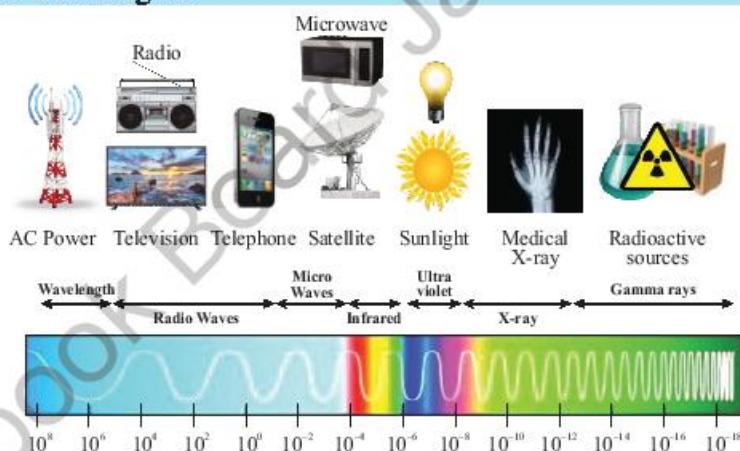

Fig: 12.4.

The electromagnetic spectrum with decreasing wavelengths as well comparison of wavelengths with the size of objects



Do You Know!

Radio waves have the longest wavelength in the electromagnetic spectrum.

From the lowest to the highest frequency or longest to shortest wavelength, the entire electromagnetic spectrum contains all radio waves, microwaves, infrared radiation, visible light, ultraviolet radiation, X-rays, and gamma rays. Radio waves have the longest wavelength, and gamma rays have the shortest wavelength.



Table 12.2 Electromagnetic Spectrum

Type of Electro-Magnetic wave	Sources	Applications
Radio and TV	Accelerating point charges	Communications, remote control devices, Magnetic Resonance Imaging (MRI)
Microwaves	Accelerating point charges and thermal agitation	Communications, microwave ovens, radar, Sterilization
Infrared	Thermal agitations and electronic transitions	Heating, Heat therapy, Thermal imaging,
Visible light	Thermal agitations and electronic transitions	All pervasive, optical fiber, Human vision, Photosynthesis
Ultraviolet	Thermal agitations and electronic transitions	Cancer Control, Sterilization Sunbeds, Vitamin D production
X-rays	Inner electronic transitions and fast collisions	Imaging, Cancer therapy, Medical diagnosis
Gamma rays	Nuclear decay	Nuclear medicine, Radiography, Cancer therapy



Microwave oven



RADAR



Optical fiber

SELF-ASSESSMENT QUESTIONS:

- Q1:** State two different components of the electromagnetic spectrum that have wavelengths more significant than the wavelengths of red light.
- Q2:** State at least four properties common to all electromagnetic waves.

12.3 Uses of electromagnetic waves

Electromagnetic waves have many advanced technological uses in our day-to-day life. Some of the implied uses of the main components of the spectrum are given shortly below;

(i) Radio waves – radio and television communications

Radio waves have the longest wavelengths in the electromagnetic spectrum. Stars are natural transmitters of radio waves. However, radio waves can be artificially

Fig: 12.5.
Some examples for application of EM spectrum



Do You Know!

Magnetic resonance imaging (MRI) is an advanced medical imaging technique that uses computer-generated radio waves and magnetic fields to create meticulous images of the organs and tissues in the body.

When the patient lies inside an MRI machine, the magnetic field temporarily realigns water molecules in the body. Radio waves cause these aligned molecules to produce faint signals, computed to produce 3-D MRI images — like slices in bread.

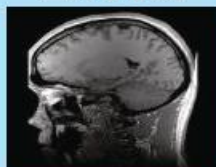

Do You Know!



Bluetooth is a short-range wireless technology standard used to exchange data between fixed and mobile devices over short distances. Blue tooth using UHF radio waves.

Wi-Fi is a networking technology that uses radio waves to allow high-speed data transfer over short distances.

generated by oscillating the current in a transmitting antenna. In a radio system, a microphone controls the current to the antenna so that the radio waves pulsate. The incoming pulsations in the radio receiver control a loudspeaker to create a copy of the original sound. Radio waves can diffract around hills, so radio can receive signals even if a hill blocks the direct route from the transmitting antenna. **Long waves** will also diffract around the curved surface of the Earth.

Radio waves are also used in television communication. Radio waves of very high-frequency VHF and ultra high-frequency UHF waves are used to telecast television programs. These waves have shorter wavelengths, and they do not diffract around hills. So, there must be a straight path between the transmitting and receiving antenna for good reception.

(ii) Microwaves – satellite television and telephone,

Microwaves have a shorter wavelength in the micrometer range and a higher frequency than all radio waves. These are usually generated inside the specialized oven by an electron tube. Satellite phones use microwaves for communication, and satellite television uses microwaves to receive satellite television programs. Microwaves can penetrate haze, light rain, clouds, and smoke as they have a higher frequency of all ranges of radio waves. However, because these waves are highly directional, the satellite dish and related components must be aligned appropriately, without any obstruction between the transmitted satellite signals and receiving satellite dish.

(iii) infra-red – household electrical appliances, television controllers and intruder alarms,

Infrared (IR), or infrared light, is electromagnetic radiation (EMR) with wavelengths longer than visible light. Infrared radiation is radiated or absorbed by molecules when they change their rotational-vibrational movements. Infra-red wireless remote controllers control various household electrical appliances that send invisible signals to an infrared receiver on a device such as televisions, video recorders, or hi-fi (High fidelity) systems.



The human body also gives out infrared radiations because of the rotational-vibrational motion of its atoms or molecules that motion sensors can detect. Intruder alarms use these motion sensors that detect the changing pattern of infrared radiations emitted by a warm body of an approaching person. This characteristic of infrared waves has been used for security purposes, particularly in military technology.

(iv) Light – optical fibers in medical uses and telephone,

The high flexibility of optical fibers makes them also ideal for use in the medical industry.

An endoscope, a medical device, is a long tube consisting of optical fibers that enable doctors to see abnormalities in organs such as the stomach intestines inside a human body.

(v) Ultra-violet – sunbeds, fluorescent tubes, sterilization,

Very hot objects, such as the Sun, emit radiations beyond the violet end of the visible spectrum, known as ultraviolet radiations. The ultraviolet is also produced by passing an electric current through the mercury vapors in the tube.

Ultraviolet radiation is further divided into three bands in order of increasing energy UV-A type, UV-B type, and UV-C type.

Wave type	UV-A	UV-B	UV-C
Wavelength	315-399nm	280-314nm	100-279nm

In fair skin, the rays can penetrate deeper and are harmful to live cells. Excess ultraviolet exposure can result in several skin diseases.

Sunbeds: Ultraviolet lamps that emit UVA and UVB radiation are used in sunbeds for artificial tanning. It is popular in countries with long periods of limited sunlight. Under medically controlled supervision, sunbeds beautify, provide the body with vitamin D, and treat certain skin conditions.

Fluorescent: When absorbed in ultraviolet, some materials convert their energy into light and glow. This phenomenon is called fluorescence.

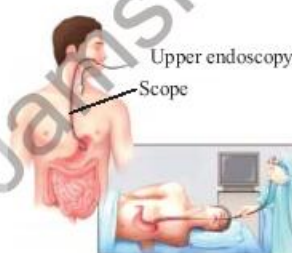

Fig: 12.6.
Endoscopy



Fig: 12.7.
Sunbed



Fig: 12.8.
Fluorescent watch dial



Do You Know!

- Many invisible things to the human eye become visible under UV light.
- Ultraviolet rays are visible to bees.
- Ultraviolet means beyond white light.
- UV light can damage the human skin



Fig: 12.9.
CT Scan



Fig: 12.10.
Radio therapy



Do You Know!

Gamma rays have wavelength of less than 100 picometer (pm)
Gamma rays have the greatest energy.

In fluorescent lamps, the inside of the tube is coated with white powder (fluoresce), which gives off light when it absorbs ultraviolet. They are commonly used in lighting houses, shops, and offices for decorating purposes.

Sterilization; as ultraviolet kills harmful bacteria, strong UVB and UVC radiations are used to sterilize food and medical equipment in hospitals.

(vi) Applications of X-rays

X-rays are produced when fast-moving electrons lose their energy quickly. For example, in an x-ray tube, the radiation is given off when a beam of fast-moving electrons hits the metal target.

The long-wavelength or low-frequency x-rays are highly penetrating that can pass through flesh but not bones. In the medical imaging field, radiologists use low-frequency x-rays to produce the x-ray images to diagnose the fracture in the bones or even tooth decay, tumors, and abnormal masses inside the body.

Computed Tomography (CT) scan is a computational diagnostic tool for detecting diseases and injuries. It uses a series of low-frequency X-rays and a computer to produce a 3D image of soft tissues and bones.

Radiation Therapy is a cancer treatment that uses controlled doses of high-frequency x-rays to kill cancerous cells and shrink tumors.

Industrial radiography is a technique of inspecting materials to detect inside defects by using high-frequency X-rays. In this method, a beam of x-rays points at the tested item. A detector is aligned with the beam on the other side of the item. The detector records x-rays that pass through the material. The thicker the material, the fewer x-rays can pass through. More rays move through that region because the material is thinner with a crack or flaw. The detector computes a picture from the rays that pass through, which shows cracks or flaws in that material.

(vii) Applications of Gamma rays

Gamma rays come from radioactive materials. They are produced when the nuclei of unstable atoms decay into a



stable nucleus or lose energy. They tend to have high energy than x-rays.

Gamma rays are used to treat cancer. These high-energy rays are directed at the cancerous tumor to kill cancer cells in oncology.

The Gamma Knife Radiosurgery is a medical procedure that uses gamma rays to destroy small tumors in the brain with less damage to surrounding cells.

Positron Emission Tomography (PET) is a functional medical imaging method. In a PET scan, a short-lived positron-emitting radioactive sampling taken suitable for a particular function (e.g., brain function) is injected into the body. Radiated positrons quickly fuse with nearby electrons and lead to two gamma rays of 511-keV traveling in opposite directions. After detecting the gamma rays, a computer generates an image that highlights the location of the biological process being examined.

Gamma rays are highly penetrating and can pass through metals; because of their extreme power, gamma rays used to radiograph holes and defects in metal castings and other structural parts.

SELF-ASSESSMENT QUESTIONS:

- Q1:** State health risks associated with high energy components of electromagnetic radiations?
Q2: What is the advantage of optical fibers in telecommunication over copper cables?
Q3: State the role played by gamma radiations in radiosurgery.



Fig: 12.11
Gamma Knife



Do You Know!

X-rays are shorter in wave length than UV rays and longer than gamma rays wavelength range (0.01 – 10 nm)



Do You Know!

PET scans are used to trace imaging of brain tumors



SUMMARY

- A prism is a transparent block of glass that produces dispersion.
- The prism refracts the narrow beam of white light that cause the spectrum of colors.
- Dispersion of white light is splitting white light into its constituent colors.
- Every wavelength of light changes speed and direction accordingly when it passes through another transparent medium.
- Dispersion of white light in a water droplet is the combination and total internal reflection.
- The electromagnetic spectrum is the range of all electromagnetic waves or radiations.
- The electromagnetic waves are transverse; oscillations of their electric and magnetic fields are perpendicular to energy transfer.
- All electromagnetic waves travel through a vacuum at the same speed of $c = 3 \times 10^8 \text{ m.s}^{-1}$.
- The electromagnetic waves travel through a transparent medium; however, they slow down when traveling through other denser mediums.
- The electromagnetic waves obey the laws of reflection, refraction, and diffraction.
- The electromagnetic spectrum, from the longest to shortest wavelength, includes all radio waves, microwaves, infrared radiation, visible light, ultraviolet radiation, X-rays, and gamma rays.
- Radio waves have the longest wavelengths in the electromagnetic spectrum.
- Microwaves have wavelengths in the micrometer range.
- Infra-red is used in wireless remote controllers.
- Intruder alarms use infrared radiations that detect the changing pattern emitted by a warm body at night.
- The white light is a small portion of the electromagnetic spectrum that is only visible to our eyes.
- Optical fibers work on the principle of total internal reflection.
- Optical fibers are widely used in communications technology.
- An endoscope is a medical device of optical fibers that enables doctors to see abnormalities in organs inside a human body.



- Ultraviolet radiations are commonly used in sun beds, fluorescence, and sterilization.
- X-rays are used in CT scans for medical imaging and radiotherapy to treat cancer.
- The cyberknife uses gamma rays in radiosu cancerous cells.
- PET uses the gamma rays in medical imaging to produce functional three-dimensional images of abnormal tissues or tumors.

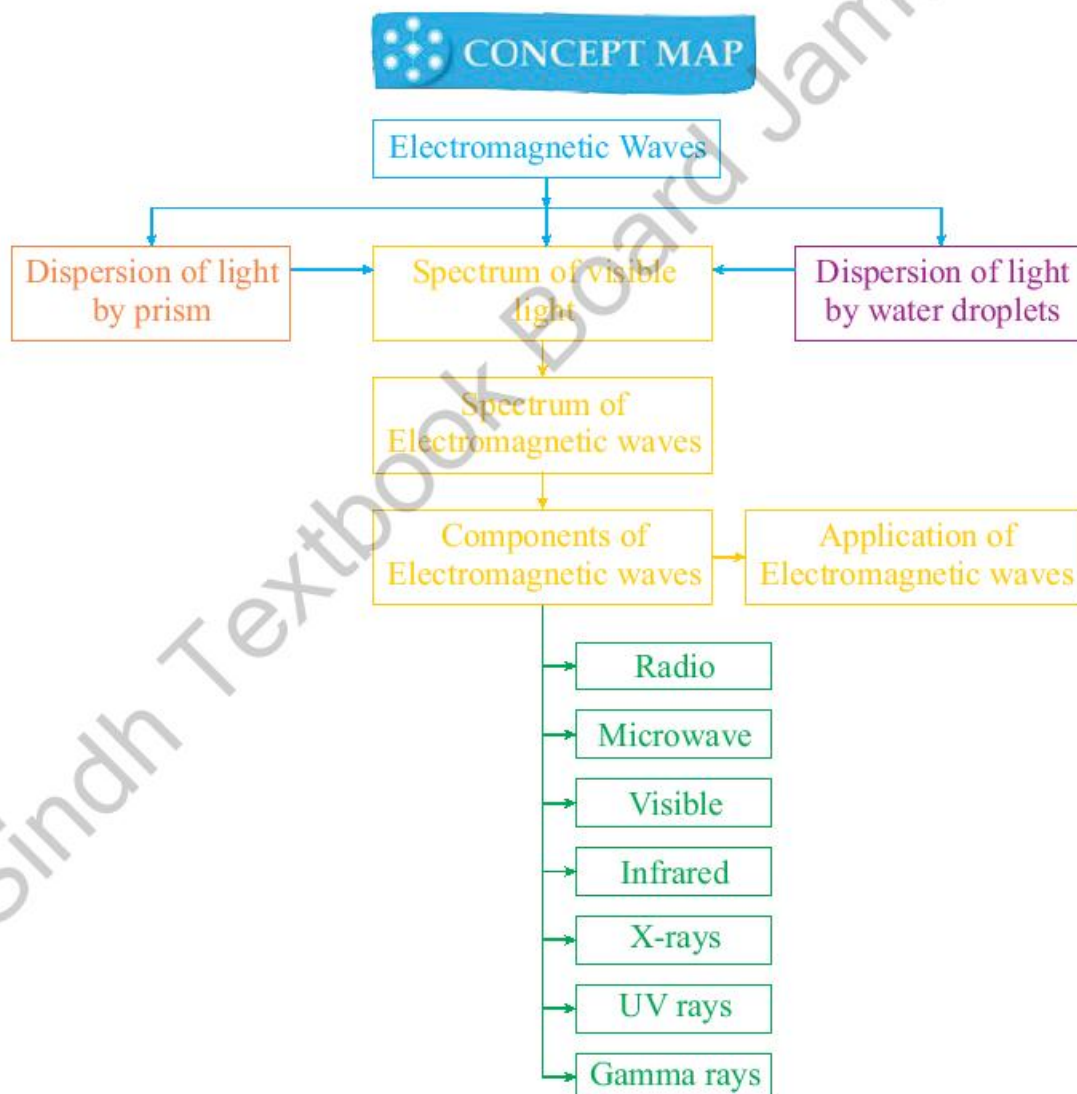



Section (A) Multiple Choice Questions (MCQs)

Choose the correct answer from the following choices:

- The waves that have maximum penetrating power to treat tumors are;
a) Ultraviolet radiation b) Microwaves
c) Gamma-rays d) Radio waves
- The electromagnetic rays used in radiotherapy to destroy cancer cells are;
a) Infrared rays b) Visible rays
c) X - rays d) Ultraviolet rays
- The Velocity of light in a diamond is
(whereas the refractive index of a diamond with respect to vacuum is 2.5)
a) 1.2×10^8 m/s b) 5×10^8 m/s
c) 1.2×10^{10} m/s d) 2.5×10^8 m/s
- The group containing only electromagnetic waves is;
a) Light waves, Radio waves, Microwaves
b) Light waves, Radio waves, Sound waves
c) Light waves, Sound waves, Microwaves
d) Radio waves, Sound waves, Microwaves
- The list that shows electromagnetic waves in order of an increasing wavelength is;
a) Microwaves, X-rays, Gamma-rays
b) Microwaves, Gamma-rays, X-rays
c) X-rays, gamma-rays, Microwaves
d) Gamma-rays, X-rays, Microwaves
- The type of electromagnetic wave used in security scanners at night is;
a) Infra-red b) Microwaves
c) Radio waves d) X-ray
- A narrow beam of white light passes from air into the glass and is refracted.
The wave characteristic remains unchanged in its;
a) Direction b) Frequency
c) Speed d) Wavelength
- The type of waves that are used in the television remote controllers;
a) Radio waves b) Infra-red waves
c) Ultra-violet waves d) Visible light



9. The color that is least deviated by a prism;
- a) Violet ray b) Green ray
c) Red ray d) Yellow ray
10. The optical phenomenon in which the splitting of white light into seven distinct colors occur is called;
- a) Refraction b) Reflection
c) Dispersion d) Diffraction

Section (B) Structured Questions

1. a) Define dispersion of light.
b) Describe the dispersion of light when passing through a glass prism.
2. a) Explain how the rainbow is produced on a rainy day?
b) Explain how the colors are related to distinct frequency or wavelength?
3. a) What are electromagnetic waves?
b) List the main components of the electromagnetic spectrum in decreasing order of their wavelengths.
c) Ultraviolet rays have a higher frequency than radio waves. Can UV rays travel faster in a vacuum?
4. Compare the properties of ultraviolet rays and radio signals.
- a) Which one travels at a faster speed?
b) Which wave has a greater frequency?
c) Which wave has a greater wavelength?
5. a) What are the main sources of radio waves?
b) What is the main advantage of using radio waves in communication?
6. Why are microwaves preferred in satellite communication?
7. a) What type of radiation is commonly used in remote controllers for household appliances?
b) How do the molecules emit infrared radiations?
c) How intruder alarms help security personnel visualize the thermal images?
8. a) On what principle do optical fibers work?
b) Reference the daily life applications of optical fibers in;
i. telecommunication
ii. medical industry?



9. a) Exposure to sunlight can damage the skin. Exposure to sunlight does not damage the skin. State the possible reason.
b) Why are ultraviolet rays used under medically supervised control in sunbeds?
10. a) Explain fluorescence.
b) Describe sterilization.
11. X-rays are used to detect cracks in metals. Explain how?
12. a) Where do gamma rays come from?
b) How are gamma radiations used in radiosurgery for destroying cancerous cells?
c) Explain the applications of gamma rays used in hospitals for medical imaging.

Section (C) Numericals

1. Electromagnetic radiation having a $15.0\text{-}\mu\text{m}$ wavelength is classified as infrared radiation. What is its frequency? Given that the speed of light is $3 \times 10^8 \text{ m/s}$. **($2 \times 10^{13}\text{Hz}$)**
2. What is the frequency of the 193-nm ultraviolet radiation used in laser eye surgery? **($1.55 \times 10^{15}\text{Hz}$)**
3. Calculate the wavelength of 100-MHz radio waves used in an MRI unit? **(3m)**
4. The distance from earth to sun is 1.49×10^{11} meters. How long a radio pulse radiated from the sun takes to reach on the earth? **(496.67 sec)**
5. Distances in space are often measured in units of light-years, the distance light travels in one year. Find the distance in kilometers in a light-year? **($9.33 \times 10^{12}\text{Km}$)**
6. What is the frequency of green light with a wavelength of $5.5 \times 10^7\text{m}$? **(5.45Hz, $5.45 \times 10^{14}\text{Hz}$)**
7. A typical household microwave oven operates at a frequency of 2.45-GHz . What is the wavelength of this radiation? **(0.1224m or 122.4mm)**

Unit - 13

Geometrical Optics

Students Learning Outcomes (SLOs)

After learning this unit students should be able to

- Describe the terms used in reflection including normal, angle of incidence, angle of reflection, and state laws of reflection
- Solve problems of image location by spherical mirrors by using mirror formula.
- Describe the use of spherical mirrors for safe driving, blind turns on hilly roads, dentist mirrors.
- Define the terminology for the angle of incidence i and angle of refraction r and describe the passage of light through the parallel-sided transparent material.
- Solve problems by using the equation $\sin i / \sin r = n$ (refractive index)
- State the conditions for total internal reflection
- Describe how total internal reflection is used in light propagation through optical fibers
- Describe the use of optical fibers in telecommunications, and the medical field and state the advantages of their use.
- Describe the passage of light through a glass prism.
- Describe how light is refracted through lenses.
- Define the power of a lens and its unit.
- Solve problems of image location by lenses using lens formula.
- Describe the use of a single lens as a magnifying glass and in a camera, projector, and photographic enlarger and draw ray diagrams to show how each forms an image.
- Define the terms resolving power and magnifying power of the lens.
- Draw a ray diagram of a simple microscope and mention its magnifying power.
- Draw a ray diagram of the compound microscope and mention its magnifying power.
- Describe the exploration of the world of microorganisms by using microscopes and of distant celestial bodies by telescopes
- Draw ray diagram of a telescope and mention its magnifying power
- Describe the correction of short-sight and Long-sight.
- Describe the use of lenses/ contact lenses for rectifying vision defects of the human eye.
- Draw ray diagrams to show the formation of images in the normal eye, short-sighted eye, and long-sighted eye.

Surface of calm water behaves like a plane mirror as shown in figure, you can see a clear image of regular reflection of Lansdowne bridge Sukkur.

REFLECTION OF LANSDOWNE BRIDGE SUKKUR



Do You Know!

Ibn al- Haytham (965-1039) realized that he was seeing images of objects outside that were lit by the sun. He concluded that light rays travel in straight path and that accomplished when these rays pass into our eyes



Do You Know!

Ibn al- Haytham's most important work is kitab al Manazir (a book about optics). His long work in optics made possible the world of media and communications we live in today.

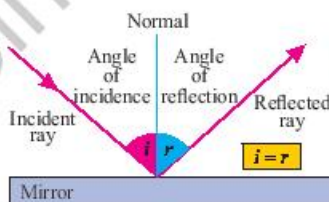

Fig: 13.1
Experimental setup

What makes things visible? During the day, the sunlight make able us to see objects. An object reflects light that falls on it. Our eyes detect reflected light, enabling us to see things. We can also see through a transparent medium as light is transmitted. Several beautiful phenomena are associated with light, such as the twinkling of stars, the beautiful colors of a rainbow, and the bending of light by a medium. The study of the properties of light helps us to explore them.

We shall study the phenomena using the rectilinear propagation of light and their application in real-life situations in this unit.

13.1. Reflection of light

To begin with, light is reflected whenever a beam of light strikes a smooth, polished surface and then returns. In other words, when a ray of light hits a surface, the surface reflects the light. In addition, the ray of light that strikes the surface is referred to as an Incident ray, but the ray of light that is reflected back is referred to as a Reflected ray. The term "normal" refers to the line that is created when a perpendicular is made between two rays on a reflecting surface.

Incident Ray = It is the ray that falls on the surface

Reflected Ray = The ray which is reflected from the surface

Normal = Perpendicular on the polished surface

P = Point of reflection

i = Angle of Incidence

r = Angle of Reflection

Laws of Reflection

Having a basic comprehension of the concept of reflection, you must also be aware of its two essential laws. It is possible to determine the reflection of an incident ray on a variety of surfaces, such as a plane mirror, water, and metal surfaces, by applying these principles. Here are the laws of reflection:



- The angle of incidence is equal to the angle of reflection (i.e. $\angle i = \angle r$) is also known as the **first law of reflection**.
- The incident ray, reflected ray and the normal to the reflecting surface all lie in the same plane is also known as the **second law of reflection**

These laws of reflection apply to all types of reflections, including reflections from spherical surfaces. These are also applicable to regular and irregular types of reflections.

SELF ASSESSMENT QUESTIONS:

Q1: Why narrow beam of white light is used in the experiment?

Q2: List everyday examples of reflection of light.

Q3: Why the angle of incidence is always equal to the angle of reflection?

13.2 Image location by spherical mirror equation

Image Formation by Spherical Mirrors

Do you know how the images are formed by spherical mirrors? How can we locate the image formed by a concave mirror? Are the images real or virtual? Are they diminished, have the same size, or enlarged?

Image formation by Concave Mirror

The ray diagrams illustrate the formation of images by a concave mirror for various positions of the object; Figure 13.2.

You can see in the ray diagrams that the nature, position, and size of the image formed depends on the position of the object at points P, F, and C. The images formed are real for some positions of an object and virtual images for a particular other position. An image formed is either reduced, has the same size, or is magnified. It depends on the position of the object. A summary of these observations is given for your reference in Table 13.1.

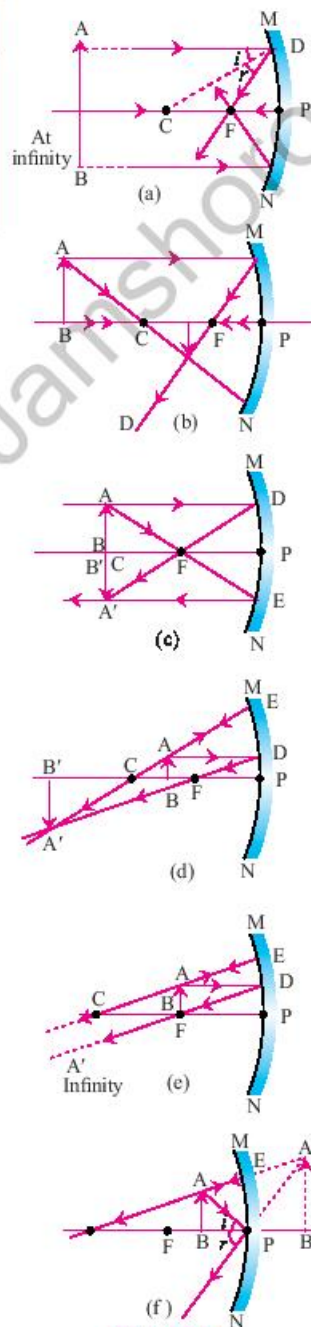

Fig: 13.2.
Ray diagrams for the image formation by a concave mirror



Do You Know!

If two plane mirrors are placed parallel, then infinite number of images are formed



Do You Know!

A spherical mirror is a mirror with a curved reflecting surface. Most curved mirrors have surfaces that are shaped like parts of a sphere. A **convex mirror** is a spherical mirror in which the reflective surface bulges towards the light source. Convex mirrors reflect light outwards and are therefore not used to focus light.

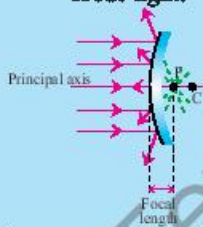

A **concave mirror** has a reflecting surface that is recessed inward away from the light source. Concave mirrors reflect light inward to one focal point. They are used to focus light.

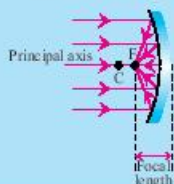

Table 13.1.
Summary of images formed by ray diagrams for different positions of the object

Position of the object	Position of the image	Size of the image	Nature of the image
At infinity	At the focus F	Highly diminished point-sized	Real and inverted
Beyond C	Between F and C	Diminished	Real and inverted
At C	At C	Same size	Real and inverted
Between C and F	Beyond C	Enlarged	Real and inverted
At F	At infinity	Highly enlarged	Real and inverted
Between P and F	Behind the mirror	Enlarged	Virtual and erect

C, the center of curvature, F, the focal point, P, optical center, p , object distance, f , focal length, q , image distance

Spherical Mirror Equation

Let us think of an object placed p cm in front of a spherical mirror of focal length f cm. The image is formed q cm from the mirror, then p , f , and q are related by the equation,

$$\frac{1}{f} = \frac{1}{p} + \frac{1}{q}$$

This is known as the mirror equation. This equation applies to both concave and convex mirrors as shown in figure 13.3.

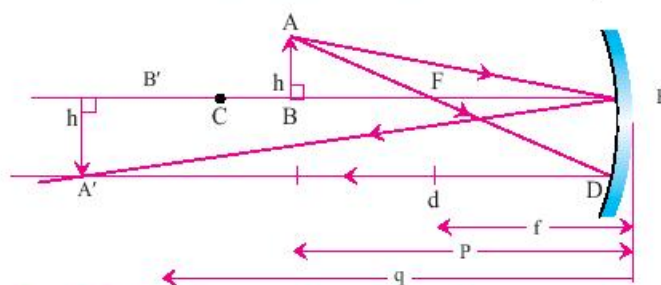

Fig: 13.3. Ray diagram of image formed by concave mirror
When applying the mirror equation, the following points must be observed:

- That all distances p , f , and q are measured from the optical center P as an origin.



- All real distances are taken positively, while all virtual distances are taken negatively.
- A concave mirror has a positive focal length, while a convex mirror has a negative focal length.

Worked Example 1

A concave mirror forms a real image at 25.0 cm from the mirror surface along the principal axis. If the corresponding object is at a 10.0 cm distance, what is the focal length of the mirror?

Solution

Step 1: Write down the known quantities and quantities to be found.

$$q = 25.0 \text{ cm}$$

$$p = 10.0 \text{ cm}$$

$$f = ?$$

Step 2: Write down the formula and rearrange if necessary.

$$\frac{1}{f} = \frac{1}{p} + \frac{1}{q}$$

Step 3: Put the values and calculate

$$\frac{1}{f} = \frac{1}{10} + \frac{1}{25}$$

$$\frac{1}{f} = \frac{5+2}{50}$$

$$\frac{1}{f} = \frac{7}{50}$$

$$f = \frac{50}{7}$$

$$f = 7.14 \text{ cm}$$

Result: The focal length of the mirror is 7.14 cm.

Use of spherical mirrors

Spherical mirrors have various applications in our everyday life such as sunglasses, rear-view mirrors, shaving mirrors. Let us discuss some of the applications given below:

Use of convex mirrors

Convex mirrors are often used as rear-view mirrors or wing mirrors in vehicles, also called driver mirrors; Fig. 13.4. These mirrors are fitted on the sides of the vehicle so the driver can see traffic behind them for safe driving. Convex



Weblinks

Encourage students to visit below link for image formation by concave mirror

https://www.youtube.com/watch?v=gPYIVBB8gyY&ab_channel=Learnhvfun



Fig: 13.4.
A wider rear view image



Fig. 13.5.
The convex mirror used
to see the vehicles on
blind turns



Fig. 13.6.
A dentist mirror

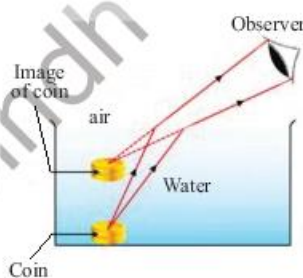

Fig. 13.7.
The coin appears to be
raised in the water

mirrors are curved outwards that reflect the light outwards, allowing the drivers view of a much larger area of the field behind them. These mirrors always give an upright, diminished, and complete image of the vehicles.

Convex mirrors are also used for Traffic Safety purposes to see the blind turns on the roads; Fig. 13.5. Convex Mirrors are easy to install – they are mounted simply and easily with the brackets. Wide-angle vision allows drivers to see around blind corners and into hidden corners. These mirrors need to be placed at the blind corners and locations to avoid accidents and collisions of vehicles.

Concave mirrors also used by dentists, can see the tooth clearly and diagnose any infection or germ attack.

SELF ASSESSMENT QUESTIONS

Q1: Are the images formed by spherical mirrors always real?

Q2: Convex mirrors are used as a rear-view mirror in vehicles that produce diminished images. Why are these mirrors preferred over plane mirrors?

13.3 Refraction of light

You know that light seems to travel along a straight pathway in a transparent medium. What happens when light enters from one transparent medium to another? Does it always move along a straight-line path? Let us recall some of our daily experiences.

When a thick glass slab is placed over printed matter, the letters appear raised when viewed through the glass slab? Similarly, the coin placed at the bottom of a water tank appears to be raised; Fig. 13.7.

Why does it happen? A pencil partly immersed in water in a beaker appears to be bent at the interface of air and water. A fish kept in water in a glass aquarium appears larger than its actual size. What is the physics behind such daily observations? We call these;

The bending effect of light as it passes from one transparent medium to another is **refraction of light**.

Consider the rectangular glass slab depicted in the following illustration.

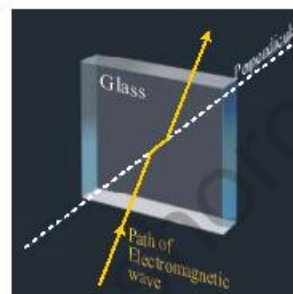
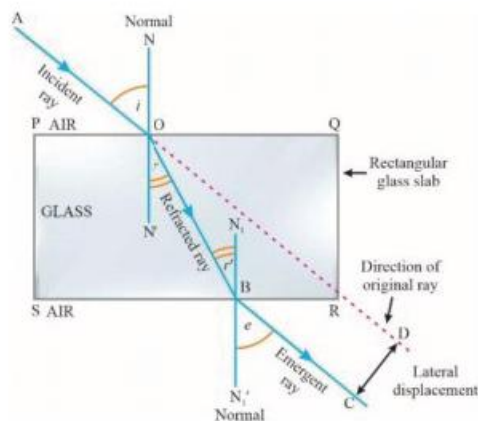

Fig: 13.8
Refraction of light
through a glass block

A ray AO strikes the face PQ at an angle of incidence $\angle i$. As it enters the slab of glass, it takes a little bend to the right, travelling along OB at a refraction angle of $\angle r$. The refracted ray OB hits the face SR at an angle of incidence $\angle r'$. The emerging ray BC exhibits a refraction angle of $\angle e$, which causes it to deviate from the normal. Therefore, the emerging ray BC is parallel to the incident ray AO; however, it has been laterally displaced with regard to the incident ray. When light emerges from a refracting material that has parallel sides, there is a shift in the pathway that the light takes.

Do You Know!

Willebrord Snell a mathematics professor, formulated the law of refraction in 1621. However, he did not publish his findings. It was only when Hugen, a dutch physicist, published Snell's findings that it was called Snell's law.



Willebrord Snell
(1580-1626)



Christiaan Huygens
(1629-1695)

Table:13.2
The angle between angle of incidence and angle of refraction and ratio of $\sin \angle I$ to $\sin \angle r$

The angle of incidence $\angle i$	The angle of refraction $\angle r$	$\sin \angle i / \sin \angle r$
20	13	1.520
30	19	1.536
40	25	1.521
50	31	1.487
60	35	1.510
70	39	1.493



Conclusions

1. A ray of light perpendicular to the glass slab or along the normal is not refracted. However, its speed changes according to the medium.
2. A ray of light incident at an angle to the normal bends towards the normal when it enters into an optically denser medium (i.e., air to glass). Similarly, a ray of light bends away from the normal when it enters an optically less dense medium (i.e., glass to air).
3. The ratio of the sine angle of incidence to the sine angle of refraction gives us a constant called the refractive index of the medium.

From this activity;

The two laws of refraction are as follows:

1. The incident ray, the normal, and the refracted ray all lie in the same plane.
2. The refractive index can be defined as the ratio of the sine of the angle of incidence to the sine of the angle refraction when the ray of light enters from one medium to another.



Fig: 13.9. Image of fish seen due to total internal reflection

For two particular refracting mediums, the ratio of the sine angle of incidence to the sine of the angle refraction is constant

$$\frac{\sin \angle i}{\sin \angle r} = \text{constant}$$

$$\frac{\sin \angle i}{\sin \angle r} = \text{refractive index}$$

$$\frac{\sin \angle i}{\sin \angle r} = n$$

$$\text{or } n = \frac{\sin \angle i}{\sin \angle r}$$

This is also known as Snell's law.

Refraction of light is caused by a change in speed, so the wavelength of the ray and its direction are also changed at the interface of two different mediums. However, the frequency of light does not change as the color used remains unchanged. Thus,



Refractive Index = $\frac{\text{speed of light in vacuum or air}}{\text{speed of light in the medium}}$

$$n = \frac{c}{v}$$

Worked Example 4

The refractive index of the diamond is 2.42. What is the speed of light in a diamond?

Solution:

Step 1: Write down the known quantities and quantities to be found

$$n = 2.42$$

$$c = 3 \times 10^8 \text{ m/s}$$

$$v = ?$$

Step 2: Write down the formula and rearrange if necessary.

$$n = \frac{c}{v}$$

$$v = \frac{c}{n}$$

Step 3: Put the values and calculate

$$v = 3 \times 10^8 / 2.42$$

$$= 1.24 \times 10^8 \text{ m/s.}$$

Hence, the speed of light in a diamond is $1.24 \times 10^8 \text{ m/s}$.

Table:13.3

Refractive index, speed of light and critical angle in some transparent material

Medium	Refractive Index	Speed of light ($\times 10^8 \text{ ms}^{-1}$)	Critical angle
Diamond	2.417	1.25	24.4°
Glass (flint)	1.66	1.81	37.0°
Glass (Crown)	1.517	2.01	41.2°
Perspex	1.495	2.00	42.0°
Water	1.333	2.25	48.8°
Ice	1.309	2.30	49.8°
Air	1.0003	2.99	88.6°
Vacuum	1.000	3.00	90.0°



Do You Know!

The greater the value of the refractive index of a medium, the greater the change in speed as well the greater bending of light when it passes from air into that medium.

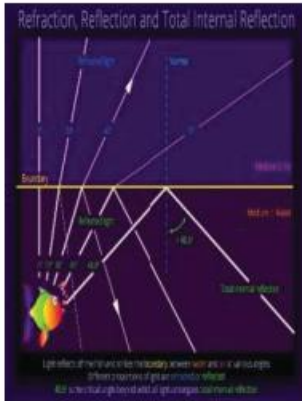

Fig: 13.10
What a swimmer can see inside the water?

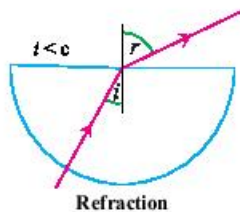

Fig: 13.11 (a)

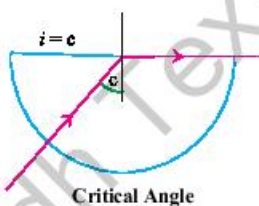

Fig: 13.11 (b)

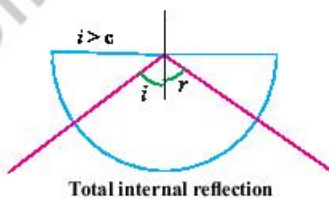

Fig: 13.11 (c)

SELF-ASSESSMENT QUESTIONS

- Q1:** When a ray of light passes through a medium to another of different optical densities perpendicularly, it does not change its direction. Is it also refraction?
- Q2:** List the physical quantities that change when refraction occurs.
- Q3:** Which physical quantities do not change during refraction?

13.4 Total internal reflection

Figure 13.10 given shows an underwater reflection of a fish. This phenomenon is due to the **total internal reflection** of light. This phenomenon can occur when light passes from an optically denser medium to a rare medium. To understand this unique behavior of light, we have first to understand the **critical angle**.

When a ray of light passing through in a dense medium enters into a rare medium, it bends away from the normal; Fig.13.11 (a). If the angle of incidence ' i ' increases, the angle of refraction ' r ' also increases. For a particular value of the angle of incidence, the angle of refraction becomes 90° ; Fig.13.11 (b).

The angle of incidence that causes the refracted ray in the rarer medium to bend through 90° is called the critical angle. If the angle of incidence in the glass is increased beyond the critical angle, no light ray is refracted through the water to air interface. The entire light is reflected into the same denser medium; Fig.13.11 (c).

If a ray passes from a dense medium to a rare medium and its angle of incidence is greater than the critical angle, the incident ray is reflected into the dense medium. This phenomenon is called total internal reflection.



Worked Example 5

Calculate the value of critical angle for water refracted angle at 90° . The refractive index of water is 1.33.

Solution:

Step 1: Write down the known quantities and quantities to be found

$$\angle r = 90^\circ$$

$$n = 1.33$$

$$\angle c = ?$$

Step 2: Write down the formula and rearrange if necessary.

$$n = \frac{\sin \angle i}{\sin \angle r}$$

When light enters in rare from denser, Snell's law becomes

$$n = \frac{\sin \angle r}{\sin \angle i}$$

or $n = \frac{\sin 90^\circ}{\sin \angle c}$

$$n = 1 / \sin \angle c$$

$$\sin \angle c = 1/n$$

Step 3: Put the values and calculate

$$\sin \angle c = 1/1.33$$

$$\sin \angle c = 0.752$$

$$\angle c = \sin^{-1}(0.752)$$

or $\angle c = 48.8^\circ$

Result: Therefore, the critical angle of water calculated is 48.8° .

Telecommunication through optical fibers

Optical fibers consist of hair-size threads made of flexible plastic or glass fibers that transmit light over long distances. An optical fiber comprises two parts, an inner part 'core' with a high refractive index, coated with another material 'cladding'; Fig. 13.12. When a light ray enters the fiber and hits the cladding, it is reflected internally in the core as the incidence angle is larger than the critical angle, even if the fiber is bent. Light rays entering the fiber are continuously reflected at the interface between two refractive materials and cover long distances without energy loss; Fig. 13.13.

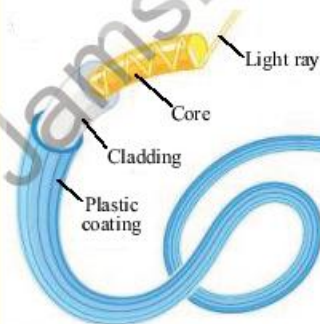

Fig: 13.12. Structure of the optical fiber

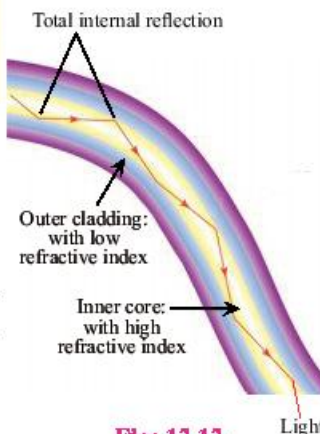

Fig: 13.13. Transmission of information through optical fiber



Do You Know!

The lens is a piece of transparent material such as glass or plastic. It focuses or disperses the light rays using refraction in such a way as to form an image of the object. The curvature of the optical surfaces classifies the lenses.

The convex lens converges the rays of light parallel to the principal axis on the focal point after passing through it. The concave lens diverges the rays of light if they approach parallel to the principal axis. After refraction light rays appear to originate from the focal point.

SELF ASSESSMENT QUESTIONS

- Q1:** State the conditions necessary for total internal reflection to occur.
Q2: Why a swimmer underwater cannot see the objects above the water surface?
Q3: What is meant by critical angle?

13.5 Refraction through a prism

Let us perform an activity to illustrate the passage of light through a prism.

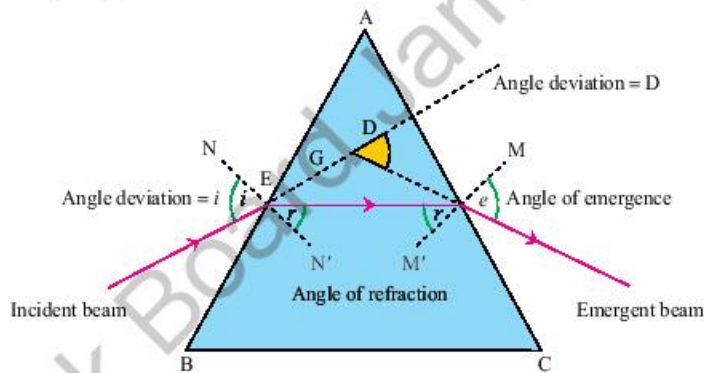

Fig. 13.14.

Tracing the passage of light rays through a glass prism

Activity

1. Fix a paper sheet on a drawing board using drawing pins.
2. Place the triangular prism resting on its base. Using a pencil, outline the prism.
3. Draw 'NEN' normal to one facet of the prism AB. Suppose an angle between 30° and 60° .
4. Fix two pins slightly apart on the line PE and label them as P and Q.
5. Look for the images of the pins at P and Q through the other facet of the prism AC.
6. Fix two pins at R and S to appear in a straight line as those of the P and Q when viewed from the AC facet of the prism.
7. Remove the pins and also the prism.
8. At point F, produce the points R and S meet by extending them.



9. At point F, produce the points R and S meet by extending them.
10. PQE is the incident ray that is extended till it meets facet AC. SRF is the emergent ray extended backward to meet at point G.
11. Now measure the angle of incidence $\angle i$, angle of refraction $\angle r$, and the angle of emergence $\angle e$ and $\angle D$.
12. Repeat the experiment for additional angles.

Observations

1. At surface AB, the ray of light enters and bends towards the normal on refraction.
2. At surface AC, the ray of light bends away from the normal as it travels from one medium to the other medium.

Conclusions

The incident ray bends towards the normal when enters the prism and bends away from the normal while leaving the prism.

SELF ASSESSMENT QUESTIONS

Q1; What is aperture?

Q2; What is difference between optical centre and pole?

13.6 Image location by lens equation

How a Lens Refracts Light

Consider a monochromatic ray of light traveling parallel to the principal axis of the double convex lens. When a ray enters a lens, Lenses refract the light at each interface, i.e. air to glass and glass to air boundaries. The net effect of the refraction, the light ray, has changed its directions. Because of its special geometric shape, it converges the ray to the focal point; Fig. 13.15.

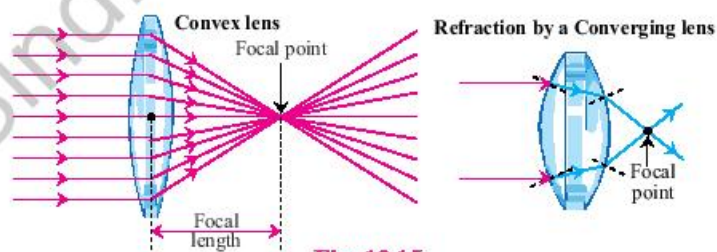

Fig: 13.15.

Converging of the ray of monochromatic light parallel to the principal axis.



Do You Know!

Concave lens: Incident rays traveling parallel to the principal axis refract through the lens and diverge in such a way will never intersect. A concave lens has a negative focal length and always produces diminished, vertically upright, and virtual images.



Do You Know!

Monochromatic rays are those rays which have a single wavelength or of single tone colour and have the same frequency. Examples of monochromatic rays are light and sodium lamps etc.



Do You Know!

A convex lens behave like a concave lens when an object placed in the focal length



Do You Know!

All the rays originated from the point of an object when they pass through the convex lens to form an image in such a way that they always tend to converge on a single point.

Similarly, when the rays of light that are not parallel to the principal axis travel through the focal point approaching the lens, they will emerge out of the lens, traveling parallel to the principal axis; Fig. 13.16.

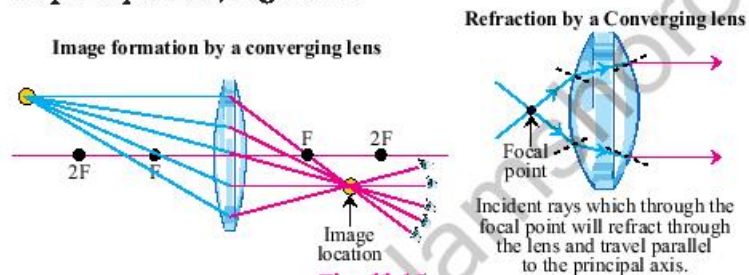

Fig: 13.16.

Converging or rays of light pass through the focal point

The power of a lens

Lenses are used to converge or diverge the incident light rays. The ability of a lens to refract the rays of light depends on its focal length. For example, a convex lens with a shorter focal length bends the light rays through a higher convergence by focusing them closer to the optical center. Similarly, a very short focal length of the concave lens will cause the light rays to diverge at higher angles away from the focal point. The degree of convergence or divergence of light rays attained by a lens expresses its refractive power.

The power of a lens is defined as the reciprocal of its focal length, measured in meters inverse (m^{-1}).

The power is represented by the letter P . The power P of a lens of focal length f is given by

$$\text{Power} = \frac{1}{\text{focal length}}$$

or
$$P = \frac{1}{f}$$

The SI unit of power of a lens is 'diopter.' It is denoted by the letter D . The power of a lens whose focal length is $1D = 1m^{-1}$.

You always remember that the power of a convex lens is positive, and that of a concave lens is negative.

Image Formation by lenses

You have studied the formation of images by spherical mirrors. How about the images formed by lenses?

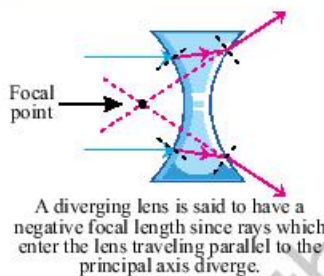

A diverging lens is said to have a negative focal length since rays which enter the lens traveling parallel to the principal axis diverge.

Refraction by a diverging lens

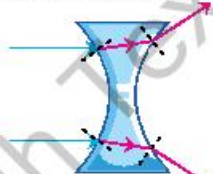

Incident rays traveling parallel to the principal axis will refract through the lens and diverge, never intersecting.

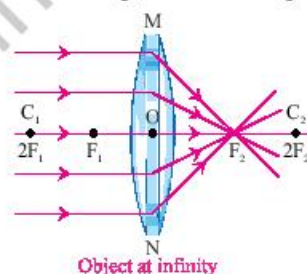

Object at infinity



The ray diagrams illustrate the formation of images by a convex lens for various object positions; Fig. 13.17.

You may observe in the ray diagrams that the nature, position, and size of the image formed by a convex lens depend on the position of the object about points $2F$, F , and C . The image formed is real for some positions of the object and a virtual image for a certain other position. The image is either smaller, has the same size, or is magnified, depending on the position of the object. An overview of these observations is given for your reference in Table 13.4.

Table 13.4.

An overview of images formed by ray diagrams for different positions of the object

Position of the object	Position of the image	Size of the image	Nature of the image
At infinity	At F_2	Extremely small	Real and inverted
Behind $2F_1$	Between F_2 and $2F_2$	Small	Real and inverted
At $2F_1$	At $2F_2$	Same as that of the object	Real and inverted
Between $2F_1$ and F_1	Beyond $2F_2$	Enlarged	Real and inverted
At F_1	At infinity	Highly enlarged	Real and inverted
Between F_1 and O	Same side of the lens	Enlarged	Virtual and erect

Lens Equation

Suppose an object is placed p cm in front of a lens of focal length f cm. Such that the image is formed q cm from the lens, then p , f , and q are related by the equation,

$$\frac{1}{f} = \frac{1}{p} + \frac{1}{q}$$

This equation is considered the lens equation. This equation is applicable for both concave and convex lenses.

When applying the lens equation, it is necessary to note the following points:

- All distances p , f , and q are measured from the optical center P .
- All real distances are taken positively, while all virtual distances are taken negatively.

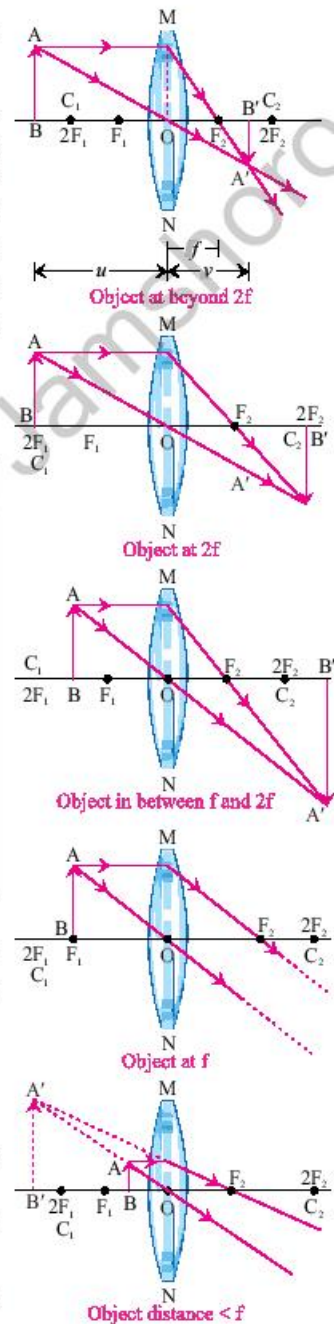

Fig: 13.17.
Ray diagrams for the image formation by a convex lens



Do You Know!

A pinhole camera is a simple camera without a lens but with a tiny aperture. The pinhole camera was invented by Ibn al-Haytham



Ibn al- Haytham
(965-1039)



Do You Know!

A magnifying glass is also behaves like a simple microscope

- A convex lens has a positive focal length, while a concave lens has a negative focal length.

Worked Example 6

A boy is standing 2.500 m in front of a camera. The camera uses a convex lens whose focal length is 0.050 m. Find the image distance (the distance between the lens and the film) and determine whether the image is real or virtual. Also, find the power of the lens.

Solution:

Step 1: Write down the known quantities and quantities to be found.

$$p = 2.500 \text{ m}$$

$$f = 0.050 \text{ m.}$$

i. $q = ?$

ii. $P = ?$

Step 2: Write down the formula and rearrange if necessary.

i.
$$\frac{1}{f} = \frac{1}{p} + \frac{1}{q}$$

ii.
$$P = \frac{1}{f}$$

Step 3: Put the values and calculate

i.
$$\frac{1}{q} = \frac{1}{0.05} - \frac{1}{2.5}$$

$$\frac{1}{q} = \frac{50-1}{2.5} = \frac{49}{2.5}$$

$$q = \frac{2.5}{49} = 0.051 \text{ m}$$

ii.
$$P = \frac{1}{f}$$

$$P = \frac{1}{0.05}$$

$$P = 20 \text{ Diopter}$$

Result: Here the image distance is positive, so the image formed is real and inverted on the film at the focal point of the lens. The power of the lens is 20 D.

Uses of Convex lenses

Have you ever seen watchmakers using a small magnifying glass to see tiny parts? Might you have touched the surface of a magnifying glass? Is it a plane surface or curved? How



does it work? Now we discuss applications of lenses in some optical devices.

The Magnifying Glass

A magnifying glass is a thin converging lens that can be used to make objects look bigger.

Figure 13.18 (a) below shows how the word (Magnifying Glass) is placed such that object distance is less than the focal length, i.e., $p < f$.

If the object is placed closer to a convex lens than the focal length, the rays never tend to meet at a point. Instead, they appear to come from the position behind the lens. The image produced is upright and magnified. It is a virtual image because no rays converge to form it, so it cannot be obtained on a screen; Fig. 13.18 (b). This type of use, a convex lens, is often called a simple microscope.

The camera

A camera uses a convex lens to reproduce a small, inverted, and small image on photographic film that is placed on the back inside the diaphragm.

While the photograph is taken, the lens is moved in or out to focus the adjustments from the film. The shutter opens and shuts quickly to allow a small amount of light through the aperture into the camera. The photo-sensitive film is kept in darkness in the diaphragm until the shutter opens.

A distant object requires the lens to film distance equal to the focal length of the lens. A nearer object requires the lens to film distance slightly more than the focal length of the lens; Fig. 13.19.

Many cameras have automated focus setting adjustments. More inexpensive cameras usually have fixed adjustments

The Projector

A projector uses a convex lens as a projection lens and pair of condenser lenses to produce a large, inverted, and real image on a screen.

In the projector, an object or a film is positioned between f and $2f$ from the projection lens. A concave mirror is used to reflect the light from the lamp onto a pair of condenser lenses so that the light from the lamp is concentrated on the film or



Fig: 13.18 (a)
A magnifying glass enlarges the letters

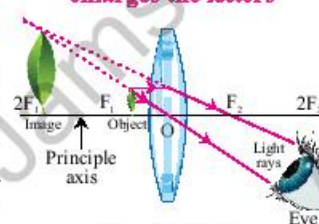

Fig: 13.18 (b)
The ray diagram of a magnifying glass

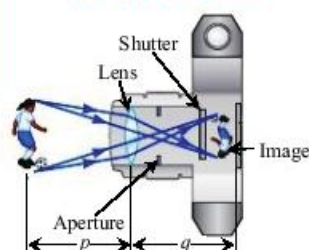

Fig: 13.19.
The cross-sectional view of a simple camera

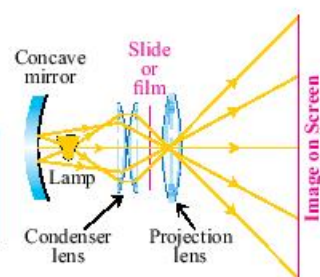

Fig: 13.20. The schematic diagram of the slide projector



slide, illuminating it evenly and directing it through the film (object) to the projection lens; Fig. 13.20. The image formed on the screen is inverted, real, and magnified.

As the image formed is inverted, must turn the film must upside down to maintain an upright picture on the screen? Move the lens from the screen to obtain a large image. The lens is moved forward or backward to get a sharp picture on the screen.

The photographic enlarger

The photographic enlarger uses a convex lens to produce an inverted, real, and magnified image of the film on photograph paper.

An enlarger is a specialized transparency projector used to produce photographic prints from glass negatives or transparencies or microfilm. The photographic enlarger works on the same principle as a projector. In the case of the enlarger, object is placed at a distance greater than F but less than $2F$. In this way, we get an inverted, real, and enlarged image, as shown in Figure 13.21.

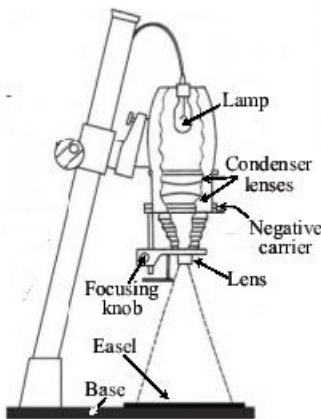

Fig: 13.21. The schematic diagram of a photographic enlarger camera

SELF-ASSESSMENT QUESTIONS:

- Q1: What is difference between real and virtual image?
 Q2: The power of the lens is reciprocal of its focal length. What does it mean?
 Q3: Why the film in the projector needs to be placed upside down?
 Q4: The concave lens is also considered to be the diverging lens. Explain why?
 Q5: A convex lens behaves like a concave lens in which condition?
 Q6: Find the image distance for an object placed 20cm in front of a convex lens with focal length 17cm.

13.7 Resolving power and magnifying power

Resolving power:

The resolving power is usually taken as the smallest distance at which two points can be seen as distinctly when viewed through the optical instrument. The greater the resolving power, the smaller the minimum distance between two points or lines that can still be distinguished. For example,



we use a high resolving power microscope to see tiny organisms individually and a telescope to view distant stars separately in the sky.

It is defined as a measure of the ability of an optical instrument to form separable images of close objects or to separate close wavelengths of radiation.

Magnifying Power

Magnifying power is usually taken as the apparent increase in angular size of an object when viewed through a microscope, telescope, or binoculars, compared with the direct view of the same object with an unaided eye. The greater the magnifying power, the enlarged image of the object that can be visualized. For example, we use the microscope of magnification 100, and then we can see the image of that object 100 times bigger. A magnifying power or magnification of, say, 100 is often referred to as a power of 100 and written as $\times 100$. It is a dimensionless number.

For an optical instrument;

Magnifying power is defined as the ratio of the image size to the object size.

Magnification = Size of image / Size of object

$$M = \text{size of image} / \text{size of object}$$

$$M = h_i / h_o$$

SELF ASSESSMENT QUESTIONS:

Q1: Define the term resolving power.

Q2: Define the term magnifying power?

13.8 Microscopy

Microscopy is the field that uses microscopes to view objects that cannot be seen with the unaided eye.

In optical instruments, the phenomenon of angular magnification is mainly used to see the magnified images of the objects. Now we discuss applications of angular magnification in some optical devices.

Simple Microscope

A simple microscope uses a convex lens to produce magnified images of small objects.

The object is placed nearer to the lens than the focal length to produce an upright, virtual, and magnified image. It is also called magnifying glass.



Do You Know!

The apparent size of an object perceived by the eye depends on the angle the object subtends from the eye. An image formed at a small distance is larger than an image formed by the same object positioned at a farther distance. Thus, objects that subtend large angles from the eye appear larger because they form larger images on the retina. For example, the tree appears smaller if you move away from it.



Do You Know!

The near point of the eye is the minimum distance to which one can see the objects distinctly without strain. It varies from person to person with age. For a normal human eye, it is 25 cm. The far point of the eye is the maximum distance to which one can see the objects. The far point of the normal human eye is infinity.

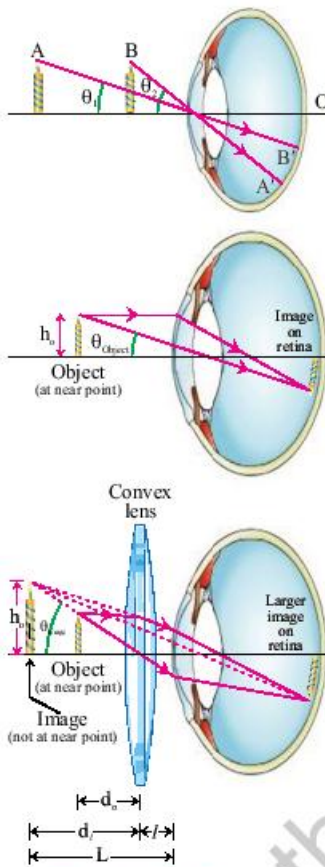

Fig: 13.22(a) Image produced on the retina without convex lens (b) Image produced with a convex lens

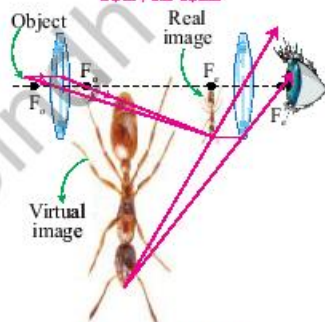

Fig: 13.23. Ray diagram of a compound microscope

Magnification by simple microscope

Let θ_0 be the angle subtended at the eye by a tiny object when placed at the near point of the eye. If the object is brought closer to the eye, the angle will increase and become θ_1 , but the eye can not see it. To see the object, we place a convex lens between the object and the eye within the focal length so that the lens makes a magnified virtual image of the object at the near point of the eye; Fig. 13.22. The magnifying power, in such a case, will be:

$$M = \frac{\theta_1}{\theta_2}$$

It can be shown that the relation gives the magnifying power

$$M = \frac{\theta_1}{\theta_2} = 1 + \frac{d}{f} = 1 + \frac{25(\text{cm})}{f}$$

Where d is the near point of accommodation, for a normal human eye, it is 25 cm. This relation indicates that a lens of a shorter focal length will have the greater magnifying power.

Compound microscope

A **compound microscope** is an upright microscope that uses two sets of lenses (a compound lens system) to obtain higher magnification than a stereo microscope.

The objective lens has a shorter focal length, f_o , than the focal length of eyepiece, f_e . It is used to study the structure of small objects.

Magnification by compound microscope

When rays of light from a point on a nearby object pass through an objective lens. The objective forms a small image I_1 on the inside focal point of the eyepiece. This image behaves as an object for the eyepiece, and the larger image I_2 is formed at the near point of the normal human eye; Fig. 13.23. This final magnified virtual image makes an angle θ_i at the eyepiece.

The magnification of a compound microscope is given by

$$M = \frac{L}{f_o} = \left(1 + \frac{25(\text{cm})}{f} \right)$$

Where L is the length equal to the distance between the



objective and eyepiece, f_o and f_e are the focal lengths of the objective and eyepiece, respectively.

Uses of Microscopes

Scientists believe that a human with a normal eye and regular vision can see the tiniest objects as small as about 0.1 millimeters, like an ant or lice. To explore an even smaller world of microorganisms, we use microscopes with high magnifying power and resolution power. The invention of the microscope allowed scientists to see cells, bacteria, and other smallest structures that cannot be seen with the unaided eye. Microscopes gave them a direct view into the unseen world of extremely tiny objects.

SELF-ASSESSMENT QUESTION:

- Q1:** Explain the near point of accommodation of an eye of a normal human.
- Q2:** Give the working principle of the optical microscopes?
- Q3:** How does magnification of a simple microscope relate to the focal length?
- Q4:** What is the difference between simple microscope and compound microscope?

13.9 Telescope

The telescope is also an optical instrument that uses two convex lenses, the objective and the eyepiece.

The objective lens has a larger focal length, f_o , than the eyepiece, which has a focal length, f_e . Telescopes are helpful because they can gather far more light than the human eye. It is used to form magnified images of distant objects.

Magnification by telescope

When parallel rays from a point on a distant object pass through the objective lens, a real image I_1 is formed at the focal point f of the objective lens. This image behaves as an object for the eyepiece. The eyepiece forms a magnified virtual image I_2 a considerable distance from the objective lens; 13.26. This enlarged virtual image makes an angle θ_i at the eyepiece.

The magnification of a telescope is given by the formula

$$M = \frac{f_o}{f_e}$$

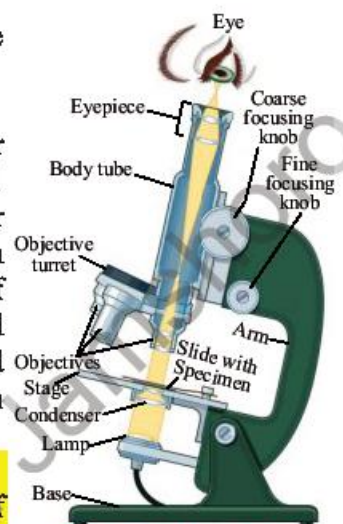

Fig: 13.24. Mechanical parts of a compound microscope



Fig: 13.25. Mechanical parts of a refracting telescope

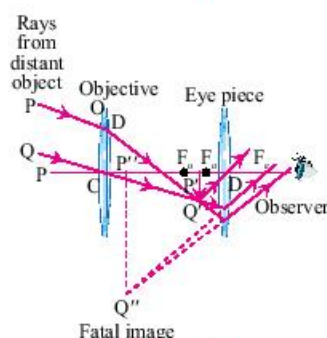

Fig: 13.26. Ray diagram of a telescope



Do You Know!

Length of Astronomical telescope given by $f_o + f_e$

Uses of Telescopes

How far the human eye can see it depends on how many light particles a distant object emits. **Telescopes** are used to collect and focus the light towards the eyepiece. Telescopes have extended our sights to the universe. Earlier telescopes revealed that Earth was not the center of the universe. They also showed mountains and craters on the moon. Later telescopes have revealed geography and weather on the planets in our solar system and new planets and asteroids. Modern telescopes provide evidence of billions of galaxies, each containing billions of stars. Telescopes are now discovering planets around the stars and possible life over there. In the future, telescopes will answer us, are we living alone in the universe?

SELF ASSESSMENT QUESTIONS

Q1: Distinguish between a compound microscope and a telescope?

Q2: How are telescopes helpful to us to explore the universe?

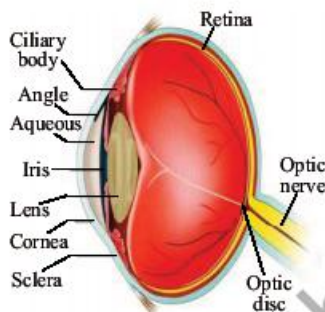

Fig: 13.27 Anatomy of a normal eye

13.10 The human eye and defect in vision

The human eye is one of the light-sensitive organs. It enables us to see the beautiful world and the colors around us. The human eye uses a convex lens system to form a real, inverted, a small image of an object on a light-sensitive screen called the retina. The eye lens is comprised of a fibrous, jelly-like material; Fig. 13.27.

The curvature of the eye lens can be adjusted to some extent by the ciliary muscles that change its focal length. When the muscles relax, the lens becomes thin. Thus, its focal length increases. This refractive effect enables us to see distant objects. When you look at objects closer to the eye, the muscles contract. The eye lens then becomes thicker. Hence, the focal length of the eye lens decreases. This refractive effect enables us to see nearby objects clearly.

Defects of the eye and their correction by lenses

For many people, changes in the shape of the eye lens are not enough to produce a sharp focusing image on the retina. In such conditions, the person cannot see the objects distinctly and comfortably.



Do You Know!

The human eye has a convex lens and 580 megapixel range and a frequency of 16Hz.



There are mainly two common refractive defects of vision. These are (i) short-sightedness and (ii) long-sightedness. The use of suitable spherical lenses can correct these defects. Let us discuss these defects and their correction.

Short sight or Myopia

A person with short sight can see nearby objects clearly but cannot see distant objects distinctly.

A person with this defect has a far point nearer than infinity. Such a person can see clearly up to a distance of several meters. In a short-sight eye, the image of a distant object is formed in front of the retina and not at the retina itself. This defect can be noticed when the lens is not thin enough to look at distant objects. So the rays are bent inward too much and converge before they reach the retina.

By placing a concave lens or contact of appropriate power in front of the eye. A concave lens of suitable power; Fig. 13.28 will bring the image back onto the retina, and thus can correct the defect.

Long-sight or Hyperopia

A person with long sight can see distant objects clearly but cannot see nearby objects distinctly.

A person with this defect has a nearer point farther away from the near-normal point (i.e., 25 cm). Such a person has to keep reading material beyond 25 cm from the eye for comfortable reading. In a long-sight eye, the image of a nearby object is formed behind the retina and not at the retina itself. This defect can be noticed when the lens is not thick enough to look at close objects. So the rays are not bent inward enough. The light rays from a close-by object are focused behind the retina.

By placing a convex lens or contact of suitable power in front of the eye. A convex lens of suitable power provides the additional focusing power required for forming the image on the retina; Fig. 13.29. Thus the defect can be corrected.

SELF-ASSESSMENT QUESTIONS

Q1: Why near-sightedness (myopia) makes far-away objects look blurry?

Q2: What is the most common treatment for refractive error of long-sight?

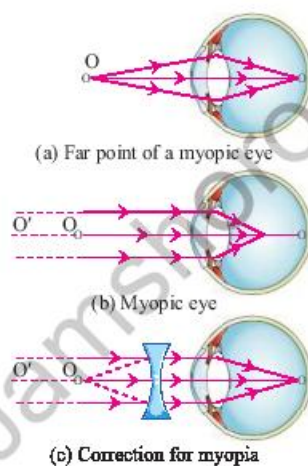

Fig: 13.28. (a) The far point of an eye of a normal person (b) short-sight eye (c) correction of short-sight eye

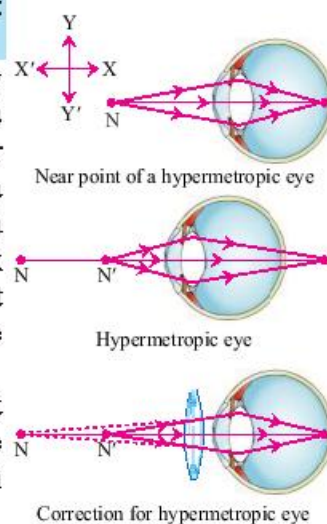

Fig: 13.29. (a) Near-point of an eye of a normal person (b) long-sight eye (c) correction of long-sight eye



SUMMARY

- A highly polished surface reflects the light.
- The incident ray, reflected ray, and the normal to the reflecting surface all lie in the same plane. This phenomenon is called the first law of reflection.
- The angle of incidence is equal to the angle of reflection (i.e., $\angle i = \angle r$). This is the second law of reflection.
- Some uses of a convex mirror are sunglasses, rearview mirrors, and shaving mirrors.
- Some applications of concave mirrors are reflectors, converging of light, and solar cookers.
- The driver uses concave or rearview mirrors to view an upright, smaller, and full vehicle image.
- The dentist uses a concave mirror to see the tooth is larger and if there is any infection or germ attack.
- A ray of light incident at an angle to the normal bends towards the normal when it enters an optically denser medium.
- A ray of light bends away from the normal when it enters a rarer medium.
- The angle of incidence that causes the refracted ray in the rarer medium to bend through 90° is called the critical angle.
- If the angle of incidence in the denser material is beyond the critical angle, the entire light is reflected into the same denser medium. This is called total internal reflection.
- Optical fibers are an important application that works on total internal reflection.
- Convex lenses are used to converge the light.
- Concave lenses are used to diverge the light.
- The power of a lens is the reciprocal of its focal length.
- The magnifying glass uses a convex lens to produce an upright and magnified image to see the tiny object.
- The camera uses a convex lens to reproduce a small, inverted, and real image on photographic film.
- The projector uses a convex lens as a projection lens and pair of condenser lenses to produce a large, inverted, and real image on a screen.
- The photographic enlarger uses a convex lens to produce an inverted, real and enlarged image of the film on a photo paper.



- The resolving power of an optical instrument is a measure of the ability to form separable images of close objects or to separate close wavelengths of radiation.
- The magnifying power of an optical instrument is the ratio between the apparent size of an object and its true size.
- The compound microscope is an optical instrument that uses two convex lenses, used to investigate the structure of the tiniest objects.
- The telescope is also an optical instrument that is used to form magnified images of distant objects.
- The human eye is a light-sensitive sense organ.
- The short-sight person can see nearby objects clearly but cannot see distant objects distinctly.
- The short-sight defect can be corrected by placing a concave lens or contact of appropriate power in front of the eye.
- The long-sight person can see distant objects clearly but cannot see nearby objects distinctly.
- The long-sight defect can be corrected by placing a convex lens or contact of appropriate power in front of the eye.

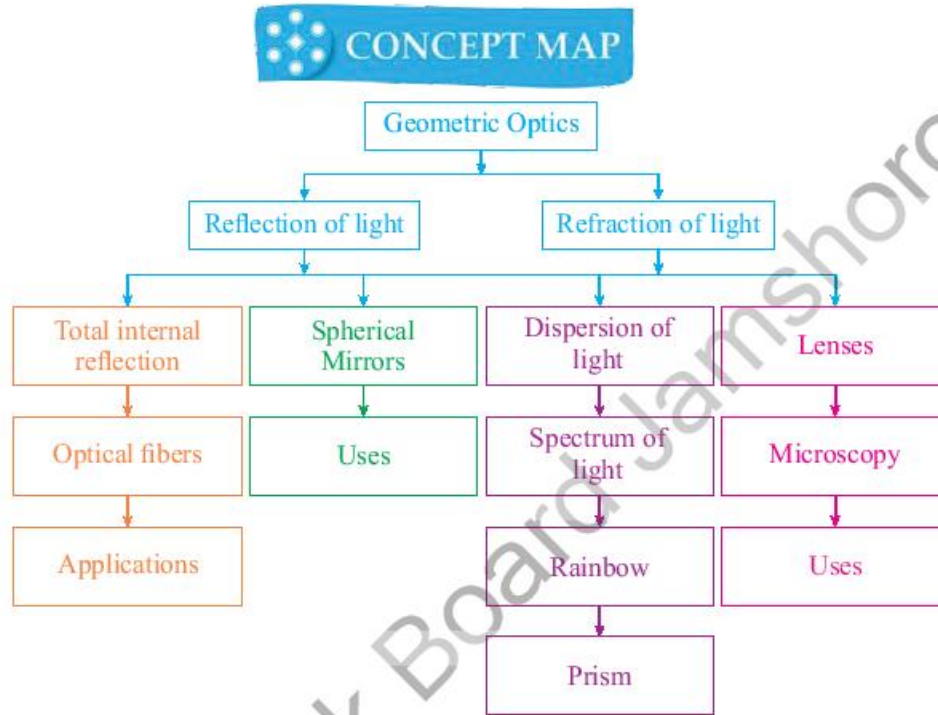

Section (A) Multiple Choice Questions (MCQs)

Choose the correct answer from the following choices:

1. In a concave mirror, the image size depends upon

(a) Size of the object	(b) Position of the object
(c) Area covered by the object	(d) The shape of the object
2. In the normal human eye, the image is formed

(a) In front of the retina	(b) Behind the retina
(c) On the retina	(d) In between lens and retina
3. When a light ray enters from a denser medium to a rare medium, it bends

(a) Perpendicular to normal	(b) Parallel to normal
(c) Toward normal	(d) Away from normal
4. In a compound microscope, as compared to an objective, the eyepiece lens has a focal length

(a) Zero	(b) negative
(c) Small	(d) Large
5. When the angle of refraction is 90° and the refractive index for water is 1.33, the critical angle is

(a) 48.8°	(b) 49.1°
(c) 50.0°	(d) 51.0°



6. To view dim stars, we use
 - (a) Compound microscope
 - (b) Simple microscope
 - (c) Endoscope
 - (d) Telescope
7. The human eye acts like a
 - (a) Camera
 - (b) Projector
 - (c) Telescope
 - (d) Microscope
8. A magnifying glass forms an enlarged
 - (a) Real and upright image
 - (b) Real and inverted
 - (c) Virtual and upright image
 - (d) Virtual and inverted image
9. The entire light is reflected into the same denser medium, which is called total
 - (a) External reflection
 - (b) Internal reflection
 - (c) External refraction
 - (d) Internal refraction
10. In the optic fiber, the core is made of glass or plastic of relatively
 - (a) Zero refractive index
 - (b) High refractive index
 - (c) Low refractive index
 - (d) No refractive index
11. A magnifying glass is also called
 - (a) Endoscope
 - (b) Compound microscope
 - (c) Simple microscope
 - (d) Telescope
12. The defect in which the image is formed beyond the retina is called,
 - (a) Long-sightedness
 - (b) Short-sightedness
 - (c) Blind spotting
 - (d) Image defect
13. The short-sightedness can be corrected by using.
 - (a) Convex glasses
 - (b) Convex mirror
 - (c) Concave mirror
 - (d) Convex glasses
14. Lenses form images through
 - (a) Dispersion
 - (b) Refraction
 - (c) Diffraction
 - (d) Reflection
15. To illuminate the inaccessible places in the tooth, dentists use
 - (a) Concave mirror
 - (b) Convex mirror
 - (c) Convex lens
 - (d) Concave lens

Section (B) Structured Questions

1.
 - a. What do you understand by the term reflection of light?
 - b. Outline a diagram to illustrate reflection at a plane surface.
 - c. Describe the following terms used in reflection:
 - i. Normal
 - ii. The angle of incidence
 - iii. The angle of reflection.
 - d. Also, express the laws of reflections.
2. Name the type of mirror used in the following situations.
 - a. Side /rearview mirror of a vehicle.



- b.** To locate the blind spots on roads of the hilly side.
- c.** Dentist mirror.

Support your answer with reason.

3. **a.** Define the refraction of light.
b. Outline the passage of light through a parallel-sided glass slab.
c. Define the following terms used in refraction:
i. The angle of incidence ii. The angle of refraction.

Also, express the laws of refraction.

4. **a.** What do you understand by the refractive index of a material?
b. Cite experimentation on how you can determine the refractive index of a parallel-sided glass slab?
c. Which physical quantity remains unaffected when refraction of light occurs?
5. **a.** What is the glass prism?
b. Describe the passage of monochromatic light rays through a glass prism.
c. Suppose a ray of light approaches the surface of the prism. What happens when it enters the glass at the angle of?
i. 0° with the normal
ii. 30° with the normal. Answer in terms of its change in the quantities of frequency, speed, wavelength, and direction.
6. **a.** What is the lens?
b. What happens if a light ray parallel to the principal axis enters a convex lens?
c. The convex lens is considered a converging lens. Explain why?
d. Describe the power of a lens and its units.
7. **a.** Define critical angle.
b. What do you understand by the term total internal reflection?
c. State the conditions required for a total internal reflection.
d. Give some practical examples of a total internal reflection in everyday life.
8. Determine the critical angle of light in a diamond? The refractive index of the diamond is 2.41.
9. **a.** What are optical fibers?
b. Describe how total internal reflection is used in an endoscope?
10. **a.** Draw the ray diagram of a magnifying glass.
b. How can you use a thin converging lens as a magnifying glass?
c. Give the magnification of magnifying glass.
11. With the help of a ray diagram, give the magnifying powers of the following optical instruments:
i. simple microscope or magnifying glass
ii. compound microscope
iii. refracting telescope



12. a. What is meant by the terms?
i. short-sight, and ii. long-sight
b. How can these defects be corrected?
i. short-sight, and ii. long-sight
c. Why is a normal eye not able to see the objects put closer than 25 cm?

Section (C) Numericals

1. A thumb pin is positioned at a distance of 15 cm from a convex mirror of a focal length of 20 cm. Determine the position and nature of the image. **(8.57cm)**
2. An image of a specimen appears to be 11.5 cm behind a concave mirror with a focal length of 13.5 cm. Find the specimen's distance from the mirror. **(6.21cm)**
3. A convex mirror used for rear-view on an automobile has a radius of curvature of 4.00 m. If a bus is located at 5.00 m from this mirror, find the image's position, nature, and size. **(1.428m)**
4. An object is placed 15 cm away from a converging lens of a focal length of 10 cm. Determine the position, size, and nature of the image formed. **(2cm)**
5. A concave lens of focal length 20 cm forms an image 15 cm from the lens. Determine the power of a lens. Also, how far is the object positioned from the lens? **(0.05cm)**
6. The angle of incidence for a ray of light from air to water interface is 40° . If the ray travels through the water with a refractive index of 1.33, calculate the angle of refraction. **(28.8°)**

.....

Unit - 14

Electrostatics

Students Learning Outcomes (SLOs)

After learning this unit students should be able to

- Describe simple experiments to show the production and detection of electric charge.
- Demonstrate the existence of different kind of charges.
- Describe experiments to show electrostatic charging by induction.
- State that there are positive and negative charges.
- Describe the construction and working principle of electroscope.
- Detect the type of charge on a body using an electroscope.
- Demonstrate that like charges repel each other and unlike charges attract each other using an electroscope.
- State Coulomb's law.
- Solve problems on electrostatic charges by using Formula $F = kq_1q_2/r_2$.
- Define electric field and electric field intensity.
- Sketch the electric field lines for an isolated +ve and -ve point charges.
- Solve problems using equation $E = F/q^0$.
- Describe the concept of electrostatic potential.
- Define the unit "volt".
- Describe potential difference as energy transfer per unit charge.
- Describe one situation in which static electricity is dangerous and the precautions taken to ensure that static electricity is discharged safely.
- Describe the use of electrostatic charging (e.g. spraying of paint and dust extraction).
- Describe that the capacitor is charge storing device.
- Define capacitance and its unit.
- Explain importance of effective capacitance of a number of capacitors connected in series and in parallel.
- Apply the formula for the effective capacitance of a number of capacitors connected in series and in parallel to solve related problems
- List the use of capacitors in various electrical appliances.

A small Van de Graaff generators are used for science education in schools or colleges to explain the behavior of static charges by performing activities such as create "lightning" or make people's hair stand up. A girl touching Van de Graaff generator at the American Museum of Science and Energy. The charged strands of hair repel each other and stand out from her head



In this chapter, we will discuss the various characteristics of static charges, such as their electric force, electric field, and electric potential, among many other things. Additionally, several applications of static electricity as well as precautions against its use will be covered. The study of charges while they are not moving is referred to as electrostatics or static electricity.

14.1 Electric charge

Charge is a basic characteristic of matter that causes electrical processes. Charged particles are found in most materials. Protons and electrons have opposing unit charges. Neutral atoms have the same number of electrons and protons.

In the 18th century, Benjamin Franklin experimented with charges. Franklin was the one who came up with the terms "positive" and "negative" to describe the two distinct types of electricity. He also used a kite's wet line to collect electricity from stormy clouds.

Electric charge is a fundamental feature of matter that is carried by some elementary particles and governs how the particles react to an electric or magnetic field. The charge is a scalar quantity with the coulomb as its SI unit.

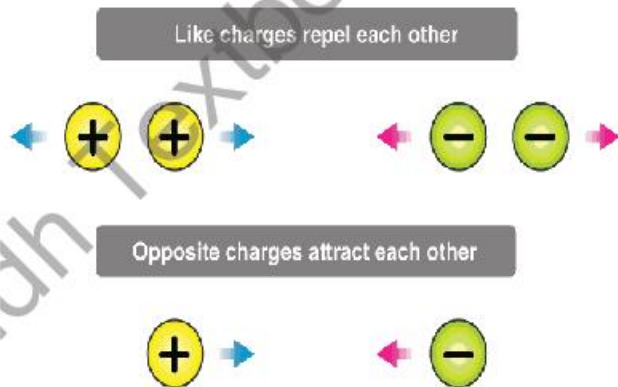

Fig: 14.1 Electric charge

Production of electric charge

When we comb our hair with a plastic comb and then bring it close to small pieces of paper, the comb will attract the paper pieces to itself as shown in figure 14.2.

Do You Know!

Electric charges at rest have been known much longer than electric currents.

Do You Know!

the word electricity comes from 'elektron', the Greek name for amber. currents.

Do You Know!

Charge introduced by "Benjamin Franklin" (1706-1790)



Fig: 14.2 Simple static electric experiment with hair comb



Fig: 14.3
The amber rubbed with silk attracts small pieces of paper

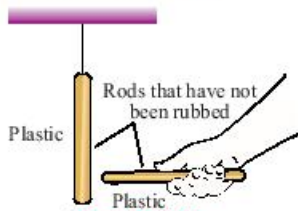

Fig: 14.4 (a)
No force is observed

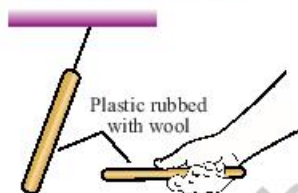

Fig: 14.4 (b)
Plastic rods repel each other

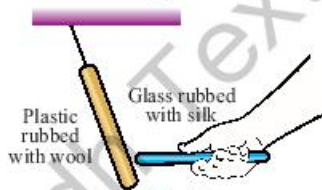

Fig: 14.4 (c)
Glass rod attracts plastic rod

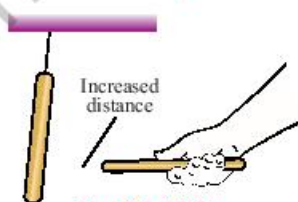

Fig: 14.4 (d)
At increased distance, forces are decreased

In the same way, rubbing amber with silk causes it to attract the small pieces of paper as shown in figure 14.3. The electric charges that are imparted to things through the process of rubbing are the cause of the properties of attraction and repulsion that are exhibited by different types of matter.

A static electric charge can be generated by rubbing together two neutral bodies. The experiments below demonstrate that rubbing can generate two distinct forms of electric charge.

Activity

Take two plastic rods. One of them should be suspended vertically as shown in figure 14.4 (a). Both rods should be rubbed with animal fur and bring them close to each other. In result we observe that the both rods have a repulsive effect on each other as shown in figure 14.4 (b). It indicates that the rods were charged as they were being rubbed.

Once again repeat same activity by taking two different rods one is of plastic and second made up of glass. Rub the glass rod with silk and in similar way plastic rod rubbed with animal fur. When we bring the glass rod that has been rubbed with silk close to the plastic rod that is suspended in the air, we notice that the rods attract each other Fig. 14.4 (c).

We observe that in the first part of activity when we take both rods made of plastic were rubbed with fur repel each other. As a result, we are going to make the assumption that the charge on both rods will be of the same kind.

In the second part of activity, the rods are different from one another, and the fact that they are attracted to one another suggests that the charges on the rods are not of the same kind but of opposite nature.

Positive charge and negative charge are the traditional names given to these different types of electrical charge. The act of rubbing causes a transfer of negative charge from one object to another as it moves from surface to surface.



The results of these experiments lead us to the following conclusions:

1. Charge is a fundamental property of a material body that determines whether or not it attracts or repels another object.
2. Two distinct types of charge are produced by friction on two distinct types of materials (such as glass and plastic).
3. Charges that are identical to one another always repel one another.
4. Charges that are not similar to one another always attract one another.
5. The only reliable indicator of charge on a body is repulsion.

Types of Charges

Electric charge, whether positive or negative, exists in discrete natural units and cannot be created or destroyed. Electric charge is a characteristic shared by many fundamental, or subatomic, matter particles. Electrons, for example, have a negative charge, while protons have a positive charge, but neutrons have no charge. Experiments show that the negative charge of each electron has the same magnitude as the positive charge of each proton charge is measured in natural units, which are equivalent to the charge of an electron or a proton, which is a fundamental physical constant. In the MKS and SI systems, the coulomb is the unit of electric charge. When the current in an electric circuit is one ampere, it is defined as the amount of electric charge that flows through a cross-section of a conductor in one second. A coulomb is made up of 6.24×10^{18} natural units of electric charge, such as single electrons or protons. According to the definition of an ampere, the electron has a negative charge of $1.602176634 \times 10^{-19}$ coulomb.

Methods of charge formation

There are three methods of formation of charges on a body as given below:

1. Induction
2. Conduction
3. Friction



Verdicks

Encourage students to visit below link for Static electric charge

https://www.youtube.com/watch?v=Vrh5FeGUTJA&ab_channel=FuscSchool-GlobalEducation



Do You Know!

Like charge repel and opposite attract by "Charles Dufay" (1698-1739)





Weblinks

Encourage students to visit below link for Electrostatic induction

https://www.youtube.com/watch?v=w80dqIZyBg&ab_channel=SimplyInfo



Do You Know!

- Proton composed by two up and one down quarks.
- Neutron composed by two down and one up quarks.

Quark	Symbol	Charge
Up	u	$+\frac{2}{3}e$
Down	d	$-\frac{1}{3}e$

$$\text{Proton} = u + u + d$$

$$P = \left(\frac{2}{3} + \frac{2}{3} - \frac{1}{3}\right)e$$

$$P = \left(\frac{2+2-1}{3}\right)e$$

$$P = \left(\frac{3}{3}\right)e$$

$$P = e$$

$$P = 1.602176634 \times 10^{-19} \text{C}$$

Induction: It is a charging method in which a neutral object is charged without actually touching another charged object

Conduction: It is charging by contact where charge is transferred to the object.

Friction: The imbalance of electrons and protons can be easily created by friction when two objects rubbing over one another. This process of charging is called charging by friction.

SELF ASSESSMENT QUESTIONS:

Q1: Why proton having positive charge?

Q2: Why neutron having neutral (zero) charge?

Q3: What causes electric charges?

Q4: How many methods used for formation of charges?

14.2 Electrostatic Induction

The formation of a charge through the influence of a nearby charged object, rather than the actual object, called electrostatic induction (Here induction means to influence without contact).

Electrostatic charging by induction.

In this section, we'll look at charge transfer through induction with a negatively charged item. Consider two metal spheres A and B, which are touching in the illustration. Take a rubber balloon that is negatively charged. When we put the charged balloon close to the spheres, the repulsion between the balloon's electrons and the spheres causes electrons in the two-sphere system to move away from the balloon. Following that, electrons from sphere A are transported to sphere B. As electrons migrate, sphere A becomes positively charged, whereas sphere B becomes negatively charged. As a result, the entire two-sphere system is electrically neutral. As depicted in the diagram, the spheres are then separated using an insulating cover such as gloves or a stand (avoiding direct contact with the metal). When the balloon is removed, the charge is redistributed throughout the spheres, as illustrated in Figure 14.8.

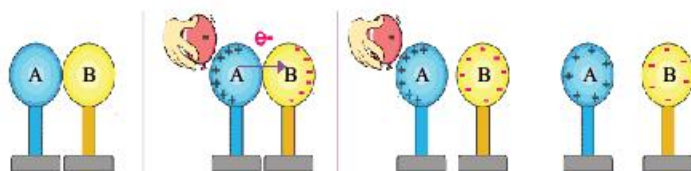

Fig: 14.5 Electric Charge

When a negatively charged balloon is introduced close to the sphere system, the electrons in the sphere are forced to go away due to repulsion. As electrons migrate, sphere A becomes totally positive and sphere B becomes completely negative.

SELF ASSESSMENT QUESTIONS:

Q1: What is tribo electric field?

Q2: Can a charge body attract neutral body?

14.3 Electroscope

In 1600, British physician William Gilbert constructed the first electroscope with a pivoting needle, called versorium.

An electroscope is a scientific instrument for detecting the presence of an electric charge on a body.

Electroscope detects test charge based on Coulomb electrostatic force. Because the electric charge of an item is proportional to its capacitance, an electroscope may be thought of as a rudimentary kind of voltmeter. Quantitative measurement of charge is performed with an electrometer.



Fig: 14.7 Electroscope

Do You Know!

- Tribo electric effect is the part of static electricity.
- Formula for charge in term of current
 $q = I \cdot t$
- Charge are quantized, finding by
 $q = ne$



**Fig: 14.6
William Gilbert
(1544–1603)**

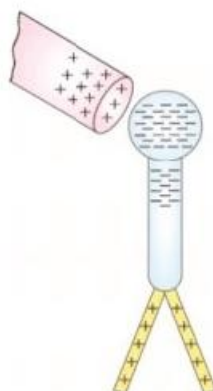

Fig: 14.9 (a)



Fig: 14.9 (b)

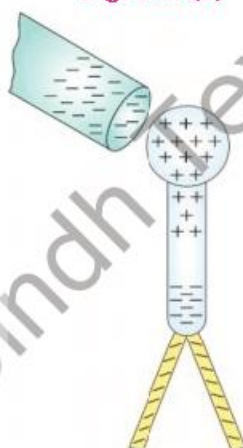

Fig: 14.9 (c)

Construction and working of the electroscope.

The operation of an electroscope is based on the atomic structure of elements; charge induction, the internal structure of metal elements, and the concept that similar charges repel each other while unlike charges attract each other. These four concepts form the basis of the electroscope's working principle.

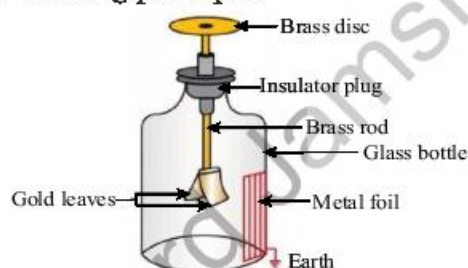

Fig: 14.8 Schematic diagram of electroscope

An electroscope has a metal detector knob on top and metal leaves on the connecting rod. When there is no charge present, the metals' leaves are allowed to hang. When an item with a charge is brought near an electroscope, one of two things may happen.

Positive charges attract electrons in the electroscope's metal, which migrate upward out of the leaves. This causes the leaves to have a transient positive charge, and since similar charges repel, the leaves split as illustrated in figure 14.9 (a). When the charge is released, the electrons return to their normal places and the leaves relax figure 14.9 (b).

When the charge is negative, the electrons in the electroscope metal reject and migrate toward the leaves. When the leaves are temporarily negatively charged, they split once again because opposite charges repel one another figure 14.9(c). If the charge is removed, the electrons return to their original location and the leaves relax.

An electroscope reacts to a charge by moving electrons into or out from the leaves. In both circumstances, the leaves separate. The electroscope cannot tell whether a charged item is positive or negative; it just detects an electrical charge.



SELF ASSESSMENT QUESTIONS:

Q1: When a charged body is brought near an electroscope, what happens?

Q2: How can we charge an electroscope?

Q3: Which device is used to detect whether an object is charged?

14.4 Coulomb's law

A French physicist Charles Augustin de Coulomb in 1785 coined a tangible relationship in mathematical form between two bodies that have been electrically charged. The force causing the bodies to attract or repel each other which is known as Coulomb's law or Coulomb's inverse-square law.

This law states that

The magnitude of electrostatic force of attraction or repulsion between two point charges is directly proportional to the product of magnitudes of charges and inversely proportional to the square of the distance between them.

Consider two point charges q_1 and q_2 which are (r) distance apart, then according to Coulomb's law.

$$F \propto q_1 q_2 \quad \dots(14.1)$$

and $F \propto \frac{1}{r^2} \quad \dots(14.2)$

By combining the equation (14.1) and (14.2)

$$F \propto \frac{q_1 q_2}{r^2} \quad \text{OR} \quad F = K \frac{q_1 q_2}{r^2} \quad (14.3)$$

Where k is the constant of proportionality

$$K = \frac{1}{4\pi\epsilon}$$

$$F = \frac{1}{4\pi\epsilon} \frac{q_1 q_2}{r^2}$$

$$\frac{1}{4\pi\epsilon} = 8.99 \times 10^9 \text{ N-m}^2/\text{C}^2$$

$$K \cong 9.0 \times 10^9 \text{ N-m}^2/\text{C}^2$$

$$\epsilon = 8.85 \times 10^{-12} \text{ C}^2/\text{N-m}^2$$



Fig: 14.10
Two point charges separated by distance r



Do You Know!

ϵ_0 Its called permittivity of free space and read as "Epsilon Naught"



Weblinks

Encourage students to visit below link for notion of charges

https://www.youtube.com/watch?v=2GQTfpDE9DQ&ab_channel=KhanAcademy

Worked Example 1

Calculate the force of attraction between two point charge of $+2\text{mC}$ and -3mC , if they apart of 1cm .

Solution

Step 1: Write down the known quantities and quantities to be found.

$$q_1 = 2\text{mC} = 2 \times 10^{-3}\text{C}$$

$$q_2 = -3\text{mC} = 3 \times 10^{-3}\text{C}$$

$$r = \frac{1\text{cm}}{100} = 10^{-2}\text{m}$$

Force = ?

Step 2: Write down the formula and rearrange if necessary.

$$F = \frac{kq_1q_2}{r^2}$$

Step 3: Put the values and calculate

$$F = \frac{(9 \times 10^9)(2 \times 10^{-3})(3 \times 10^{-3})}{(10^{-2})^2}$$

$$F = \frac{54 \times 10^9 \times 10^{-6}}{10^{-4}}$$

$$F = \frac{54 \times 10^9 \times 10^{-6}}{10^{-4}}$$

$$F = 54 \times 10^{9-6} \times 10^4$$

$$F = 54 \times 10^{3+4}$$

$$F = 54 \times 10^7$$

$$F = 5.4 \times 10^8 \text{N}$$

Result: The required force of attraction between two point charge is $F = 5.4 \times 10^8 \text{N}$.

SELF ASSESSMENT QUESTIONS:

Q1: Calculate the coulombs force between two protons 10cm apart from each other? Charge on proton is $1.69 \times 10^{-19} \text{C}$ and $K = 9.0 \times 10^9 \text{N-m}^2/\text{C}^2$

Q2: Is there any electrostatic force between electron and neutron?



14.5 Electric field and electric field intensity

we know that Like charges repel each other while opposite charges attract. Positively charged particle exerts a force of attraction on negatively charged while exerts a force of repulsion on positively charged particle. It is important to remember that the second charged particle also exerts an electrostatic force on the first one. As a result, it may be deduced that the area surrounding the charge is constantly under stress and exerts a force on another charge put around it. The area or space surrounding a charge or charged body where electrostatic force or stress occurs is termed electric field, dielectric field, or electrostatic field.

A region around the charged particle or object within which a force would be exerted on other charged particles or objects.

An electric field is often referred to as the electric force per unit of charge.

The formula of electric field is given as;

$$E = \frac{F}{Q}$$

Whereas,

E is the electric field.

F is a force.

Q is the charge.

Changing magnetic fields or electric charges are the most common causes of electric fields. The magnitude of an electric field is expressed using the SI unit is N/C.

The force acting on the positive charge is assumed to be pointing in the same direction as the field's direction. The electric field extends outwards radially from the positive point charge and inwards radially toward the negative point charge.

Electric field lines

The electric field that surrounds a charge may be imagined as the existence of a line of force all the way around it. Electric or electrostatic lines of force refer to a system of imaginary lines around a charged object and indicating the stress on that object. The configuration of lines of force around an isolated positive charge is seen in Fig. 14.11 (a).



Do You Know!

Concept of electric field given by
"Michael Faraday"
(1791-1867)



Do You Know!

Point charge is an electric charge. When the linear sizes of charged bodies are much smaller than the distance between them, their sizes may be ignored.

Test charge is a charge with a magnitude so small that placing it at a point has a negligible affect on the field around the point.

The fact that all observable charges are always some integral multiple of elementary charge $e = 1.6 \times 10^{-19} \text{ C}$ is known as **quantization of electric charge**.

Thus $q = \pm ne$, where
 $n=1,2,3,\dots$

$e = 1.6 \times 10^{-19} \text{ C}$ is the magnitude of the lowest possible charge which is carried by an electron and proton.

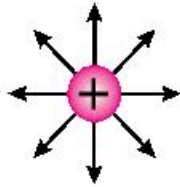

Fig: 14.11 (a)
Isolated positive charge

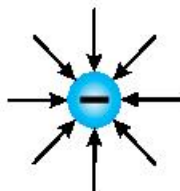

Fig: 14.11 (b)
Isolated negative charge

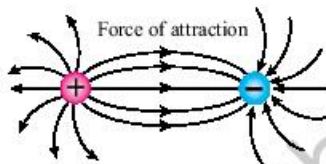

Fig: 14.11 (c)
Two equal unlike charges

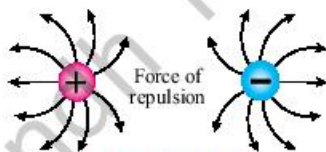

Fig: 14.11 (d)
Two equal like charges

while the arrangement of lines of force around an isolated negative charge is shown in Fig. 14.11 (b). such lines of force originate from the positive charge and terminate on the negative charge, when these charges are placed near each other. They exert the force of attraction on each other. This is shown in Fig 14.11 (c). while when two like charges are near each other, such lines will be in opposite direction as shown in Fig 14.11 (d). there exists a force of repulsion between them.

Worked Example 2

Calculate the electric field intensity if $9\mu\text{N}$ force acting on $3\mu\text{C}$ charge.

Solution

Step 1: Write down the known quantities and quantities to be found.

$$F = 9\mu\text{N} = 9 \times 10^{-6}\text{N}$$

$$q = -3\mu\text{C} = 3 \times 10^{-6}\text{C}$$

Step 2: Write down the formula and rearrange if necessary.

$$E = \frac{F}{q}$$

Step 3: Put the values and calculate

$$E = \frac{9 \times 10^{-6}\text{N}}{3 \times 10^{-6}\text{C}}$$

$$E = 3 \frac{\text{N}}{\text{C}}$$

Result: The required E is $3 \frac{\text{N}}{\text{C}}$.

SELF ASSESSMENT QUESTIONS:

- Q1:** What is meant by electric field and electric intensity?
Q2: Is electric intensity a vector quantity? What will be its direction?
Q3: calculate the force acting on a charge of $3\mu\text{C}$, when the electric field intensity is 5N/C .



14.6 Electrostatic potential

The electrostatic potential, also known as the electric field potential, electric potential, or potential drop, is defined as the amount of work that is done in order to transport a unit charge from a reference point to a given location within the field without causing an acceleration.

The volt is the standard SI unit for measuring electrostatic potential.

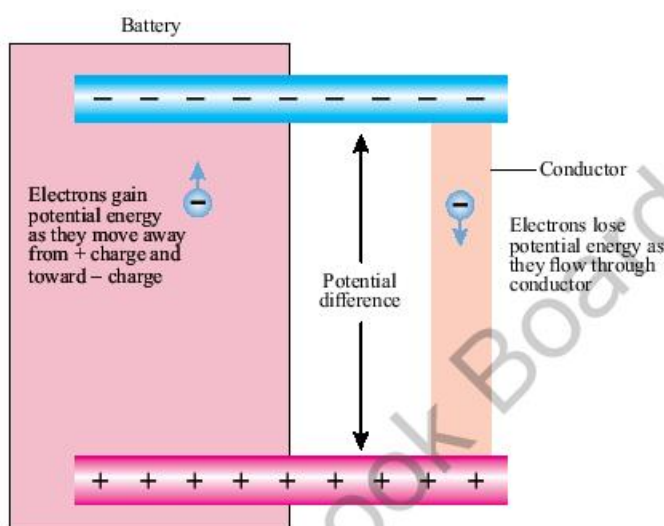

Fig: 14.12 Electrostatic potential

Electric potential energy is possessed by an object by the virtue of two elements, those being, the charge possessed by an object itself and the relative position of an object with respect to other electrically charged objects. The magnitude of electric potential depends on the amount of work done in moving the object from one point to another against the electric field as shown in figure 14.12.

When an object is moved against the electric field it gains some amount of energy which is defined as the electric potential energy. For any charge, the electric potential is obtained by dividing the electrical potential energy to the quantity of charge.

$$V = \frac{W}{q} = \frac{\text{Electrical potential energy}}{\text{Charge}}$$



Do You Know!

Electrostatic potential is measured in statvolt



Weblinks

Encourage students to visit below link for Electric potential

https://www.youtube.com/watch?v=PEcPcNMfNks&ab_channel=7activestudio



Do You Know!

S.I unit of potential difference and electromotive force is same “Volt”



Weblinks

Encourage students to visit below link for Electric potential difference

https://www.youtube.com/watch?v=SNIOPxZ-Ev4&ab_channel=Don%27tMemorise

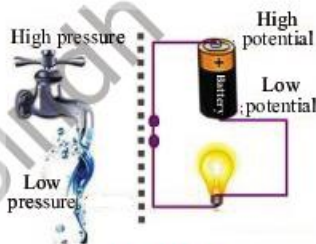

Fig: 14.13
Simple example to understand the potential difference

Volt:

Volt is the unit of electrical potential, potential difference, and electromotive force in the SI system;

The potential difference that exists across a resistance of one ohm while a current of one ampere is flowing through it.

The unit of voltage known as the volt was named after the Italian scientist Alessandro Volta (1745–1827).

Worked Example 3

Calculate the p.d of 300mJ of workdone on a 150mC charge?

Solution

Step 1: Write down the known quantities and quantities to be found.

$$W = 300\text{mJ}$$

$$C = 150\text{mC}$$

$$V = ?$$

Step 2: Write down the formula and rearrange if necessary.

$$V = \frac{W}{q}$$

Step 3: Put the values and calculate

$$V = \frac{300\text{mJ}}{150\text{mC}}$$

$$V = 2\text{volts}$$

Result: The required voltage is 2 volt.

Potential difference:

The energy possessed by Electric charges is known as electrical energy. A charge with higher potential will have more electric potential energy and the charge with lesser potential will have less electric potential energy. The current always moves from higher electric potential to lower electric potential. The difference in these energies per unit charge is known as the electric potential difference.

It is the work done per unit charge to move a unit charge from one point to another in an electric field. Electric potential difference is usually referred as Voltage difference.



14.7 Applications of electrostatics.

There are many applications of electrostatics which are given below:

- The Van de Graaff Generator. ...
- Xerography. ...
- Laser Printers. ...
- Ink Jet Printers and Electrostatic Painting. ...
- Smoke Precipitators and Electrostatic Air Cleaning.

Spray painting:

The friction that occurs when the spray exits the nozzle gives it an electrical charge. The droplets all have the same charge, which means that they will repel each other since similar charges repel; as a result, the droplets disperse themselves equally throughout the surface.



Fig: 14.14
Spray paint

Electrostatic Air Cleansing:

Electrostatic precipitators is another name for these types of devices. It is possible to ionise the dust and smoke particles in the air by passing them through an electric cell. By bringing a charged collecting plate into touch with the charged dust and smoke particles, an attraction is created between the two.

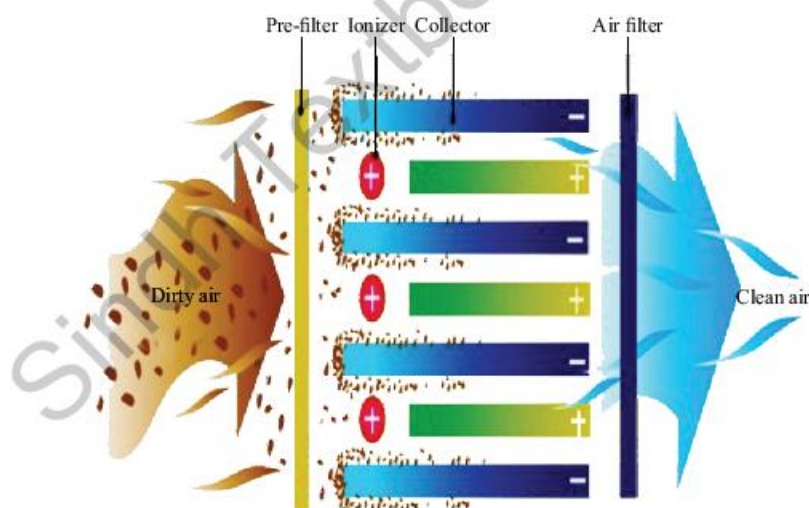

Fig: 14.15 Systematic diagram of electrostatic air cleansing



Do You Know!

Capacitor also called "Condenser"

Condenser is a term used for a capacitor in the past. In time the term ceased to be used, with capacitor turning into the most commonly used term from 1926. Condenser and capacitor are one and the same viewed from electrical perspective.



14.8 Capacitor and capacitance

The capacitor is a simple electronic device or component and is used to store charge. It is a system of two isolated conductors that can store electric charge as shown in the figure 14.16

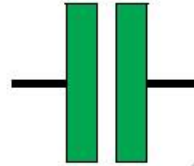

Fig: 14.16 Symbol of capacitor

A Capacitor stores a large amount of charge per volt in a very small area of the conductor. Two conductors of any shape (plates) carrying equal and opposite charges, separated from each other by an insulating material medium called Dielectric formed a Capacitor. Different types of capacitors categorized according to the shape of plates as shown in figure 14.17.

Fig: 14.18
Capacitor of different capacitance



Do You Know!

Energy of capacitor finding by:

$$E = \frac{1}{2} CV^2$$

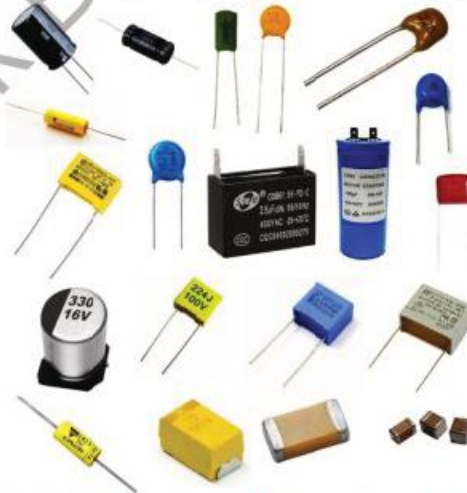

Fig: 14.17 Capacitor of different size and shapes

Capacitance:

The ability of storing charges in a Capacitor is known as Capacitance. When the Capacitor is connected to a battery of V volts, one plate draws positive charge and the other plate draws negative charge from the battery till the potential difference between the plates also becomes V volts.



Charge Q which resides on any one of the plate is directly proportional to the potential difference between the plates.

$$Q \propto V$$

$$\text{Or } Q = CV$$

The constant C is called Capacitance of the Capacitor and the equation $Q = CV$ is called equation of Capacitor.

So,

$$C = \frac{Q}{V}$$

This shows that unit of capacitance is Coul / Volt and this unit is also called Farad because 1Farad = 1Coul /Volt.

Thus, if a charge of 1Coulomb given to any one of the plate produces a potential difference of 1Volt between the plates, then the Capacitance of Capacitor is said to be 1Farad.

So, Capacitance is the ratio of the charge on one of the conductors (q) to the potential difference (V) between them.

Symbolically:

$$C = \frac{q}{V}$$

Capacitance = $\frac{\text{Magnitude of charge on conductor.}}{\text{Magnitude of potential difference.}}$

Factors on which capacitance depends:

Capacitance depends on these factors:

- Area of the plate. Capacitance increases if area of the plate increases.
Hence $C \propto A$.
- Distance between the plates. Capacitance increases if the separation distance between the plates decreases.
Hence $C \propto \frac{1}{d}$
- Dielectric Constant (ϵ_r) capacitance increases if insulating medium of high dielectric constant is used.
Hence $C \propto \epsilon_r$.



Do You Know!

If dielectric placed between plates of capacitor its electric field and electric potential will be decrease



Do You Know!

If parallel plate capacitor without oil between the plates (dielectric constant of oil, $K=2$) has a capacitance c . If the oil is removed, then the capacitance of the capacitor becomes half



Weblinks

Encourage students to visit below link for How capacitor works

https://www.youtube.com/watch?v=5hFC9ugTGLs&ab_channel=NationalMagLab



Do You Know!

In parallel combination of capacitor voltage same on each one capacitor



Weblinks

Encourage students to visit below link for Combination of capacitors in parallel

https://www.youtube.com/watch?v=BIPi0vXdssE&ab_channel=PhysicsVideosbyEugeneKhutoryansky

Combination of capacitors:

For a circuit the capacitance of a desired value can be obtained by different combination of capacitors and that combination may be:

- Parallel combination
- Series combination
- Series Parallel combination.

1. Parallel combination of capacitors:

Let suppose capacitor consists on such a combination that positive terminal of each capacitor is connected with the positive terminal of the other capacitor and negative terminal of each capacitor is connected with the negative terminal of the other capacitor. Then the combination is said to be Parallel combination.

If three Capacitors C_1 , C_2 and C_3 are connected in Parallel and further connects them with a battery of V volts then:

C_1 draws charge Q_1 , C_2 draws charge Q_2 and C_3 draws charge Q_3 . Then:

$$Q = Q_1 + Q_2 + Q_3.$$

By applying Capacitor equation. We get:

$$Q_1 = C_1V, Q_2 = C_2V, Q_3 = C_3V, Q = C_eV$$

So capacitance becomes:

$$C_eV = C_1V + C_2V + C_3V$$

$$C_eV = (C_1 + C_2 + C_3) V$$

$$C_e = C_1 + C_2 + C_3$$

So now according to the equation the equivalent capacitance or overall total capacitance is equal to the sum of individual Capacitors.

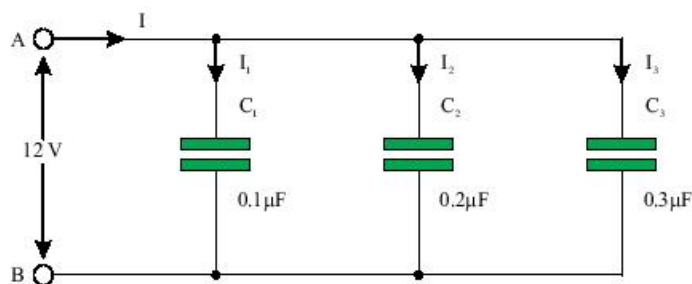

Fig: 14.19 Parallel combination of three capacitors



Worked Example 4

Find the net capacitance of four capacitors. When capacitance of each capacitor is $1\mu\text{F}$ and connected parallel.

Solution

Step 1: Write down the known quantities and quantities to be found.

$$C_1 = C_2 = C_3 = C_4 = 1\mu\text{F}$$
$$C_{\text{net}} = ?$$

Step 2: Write down the formula and rearrange if necessary.

$$C_{\text{net}} = C_1 + C_2 + C_3 + C_4$$

Step 3: Put the values and calculate

$$C_{\text{net}} = (1+1+1+1)\mu\text{F}$$
$$C_{\text{net}} = 4\mu\text{F}$$

Result: The required capacitance becomes is $4\mu\text{F}$.

2. Series combination of capacitors:

Let suppose Capacitors are consists on such a combination that positive terminal of one Capacitor connected with the negative terminal of the other Capacitor and the negative terminal of first Capacitor is connected with the positive terminal of the other Capacitor. Then the combination is said to be Series combination.

If three Capacitor C_1 , C_2 and C_3 are connected in Series and further connects them with a battery of V volts. Then: Positive plate of Capacitor C_1 draws charge $+Q$ from the battery and negative plate of C_3 draws charge $-Q$ from the battery.

The charge $+Q$ on the positive terminal (Left Plate) of C_1 attracts free electrons from the left plate of C_2 and these free electrons are accumulated on the right plate of C_1 . Thus right plate of C_1 becomes negatively charged with a charge $-Q$. in this way every Capacitor becomes charged.

If voltage acquired by each Capacitor is V_1 , V_2 , V_3 by applying Capacitor equation on C_1 , C_2 and C_3 . We get:



Web links

Encourage students to visit below link for Combination of capacitors in series

https://www.youtube.com/watch?v=P_hCvjKdG4I&ab_channel=7activestudio



Do You Know!

In series combination of capacitor charges equally stored on each capacitor.



$$Q = C_1 V_1, Q = C_2 V_2, Q = C_3 V_3, Q = C_e V$$

$$V_1 = \frac{Q}{C_1}, V_2 = \frac{Q}{C_2}, V_3 = \frac{Q}{C_3}$$

$$\frac{Q}{C_e} = Q \left(\frac{1}{C_1} + \frac{1}{C_2} + \frac{1}{C_3} \right)$$

$$\frac{1}{C_e} = \frac{1}{C_1} + \frac{1}{C_2} + \frac{1}{C_3}$$



Weblinks

Encourage students to visit below link for Capacitor physics and applications

https://www.youtube.com/watch?v=L6cgSxpGmDo&ab_channel=HowToMechatronics

So now according to the equation:

The reciprocal of equivalent capacitance is equal to the sum of reciprocals of individual capacitance.

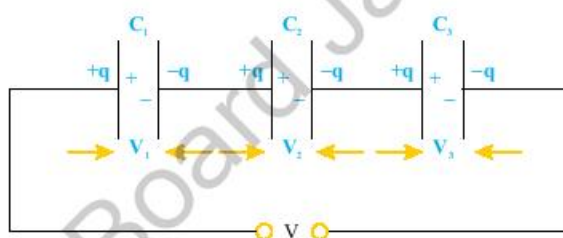

Fig: 14.20 Series combination of three capacitors

Uses of Capacitors:

Electrical and electronic circuits use capacitors in a broad variety of ways. They are utilized, for instance, in the process of tuning transmitters, receivers, and transistor radios. Also, they are utilized to run table fans, ceiling fans, exhaust fans, air conditioner motors, coolers, washing machines, air conditioners, and many other appliances to keep them running at a high efficiency.

It is also common to find capacitors in the electronic circuitry of computers and other products like smartphones.

It is possible to utilize capacitors to distinguish between high and low frequency signals, which makes them valuable in electronic circuits. For instance, resonant circuits, which are responsible for tuning radios to specific frequencies, require the use of **variable capacitors**. These kinds of circuits are referred to as filter circuits. One capacitor may not work in all situations. In general, ceramic capacitors outperform other types and can be found in a wide variety of applications.



Weblinks

Encourage students to visit below link for Types of capacitors and How to use capacitors

https://www.youtube.com/watch?v=XXWICUiUxuY&ab_channel=EcoSignX



SUMMARY

- Electric charge is the basic physical property of matter that causes it to experience a force when kept in an electric or magnetic field.
- Electrostatic induction is the physical phenomenon in which a material can be charged without any actual contact with a charged body.
- Scientific equipment used for detecting presence of an electric charge on a body is known as electroscope.
- Coulomb's law states that the magnitude of the force between two point charges is directly proportional to the product of the magnitudes of the charges and inversely proportional to the square of the distance between them.
- Electric field is the region around a charge in which an electric test charge would experience an electric force.
- The electric Intensity is a measure of the force exerted by one charged body on another. It is a vector quantity and has unit of NC^{-1} .
- Electrostatic potential is The amount of work needed to move a unit charge from a reference point to a specific point against an electric field.
- The volt is the derived unit for electric potential, electric potential difference (voltage), and electromotive force
- Capacitor is a device which is used for storing electric charges.
- In series combination of capacitors, the reciprocal of Equivalent capacitance is equal to the sum of reciprocals of individual capacitance.
- In parallel combination of capacitors, the total capacitance always equals to the sum of individual capacitors.
- Electron volt (eV): the unit of energy and is related to joule as $1 \text{ eV} = 1.602 \times 10^{-19} \text{ J}$.



CONCEPT MAP

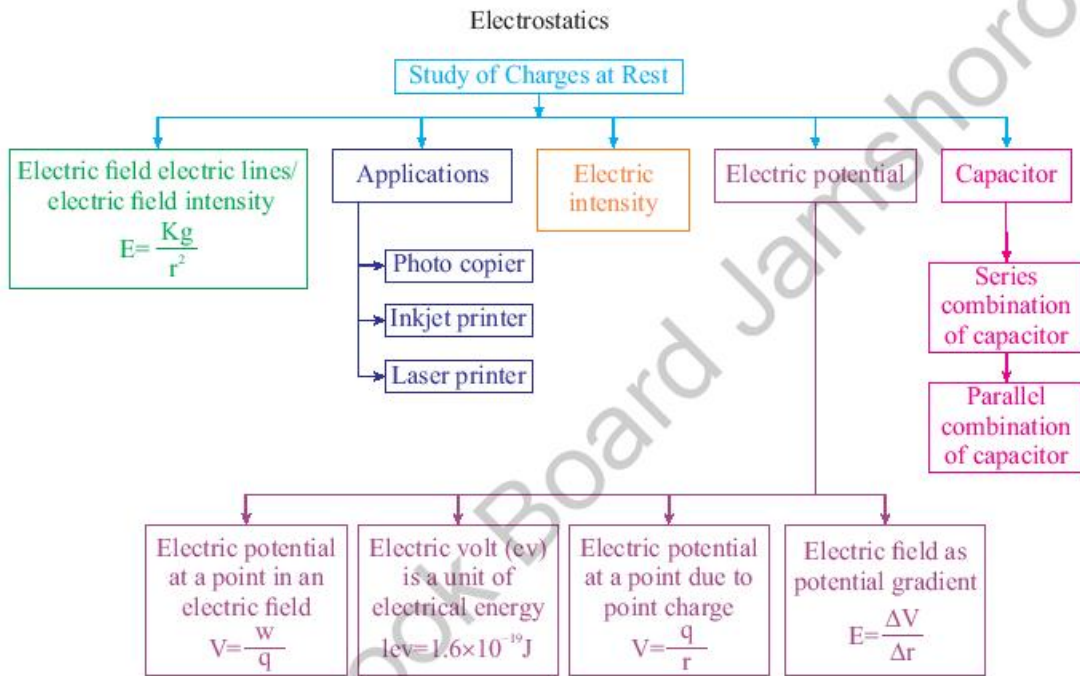



Section (A) Multiple Choice Questions (MCQs)

Choose the correct answer from the following choices:

- Branch of physics which deals with the charges at rest is called
(a) Electricity (b) Electrostatic
(c) Quantum (d) Magnetism
- The magnitude of force between two unit positive charges when the distance between them is 1m would be
(a) 0N (b) 1N (c) 2N (d) Coulombs Constant
- Coulombs law most closely resembles with
(a) Law of conservation of Energy (b) Newton's Law of Gravitation
(c) Newton's 2nd law of Motion (d) Faraday's law
- If the electrostatic force between two electrons is F Newton, then the electrostatic force between two protons at the same distance is
(a) 0N (b) 2F (c) $\frac{2}{3} F$ (d) F
- The direction of electric force and electric field intensity is
(a) Parallel to each other (b) Perpendicular to each other
(c) opposite to each other (d) In any direction
- The work done on a unit charge against electric field intensity is called
(a) Electric field (b) Electric current
(c) Electric potential (d) electric field
- The capacitance of capacitors increases when they connected in
(a) Parallel (b) Series (c) both (d) none of them
- Two capacitors of $8\mu\text{F}$ are connected in series then the equivalent capacitance is
(a) $\frac{1}{4} \mu\text{F}$ (b) $2 \mu\text{F}$ (c) $3 \mu\text{F}$ (d) $6 \mu\text{F}$
- The presence of a dielectric between the plates of capacitors, the capacitance of capacitor
(a) Increases (b) decreases
(c) remain constant (d) remain uncharged
- If the area of the parallel plate capacitor is doubled then the capacitance will be
(a) Remain uncharged (b) half
(c) Double (d) increased two times



Section (B) Structured Questions

1. Explain how electric charge can be generated and measured in very simple experiments.
2. Explain how an electroscope is built and how it operates.
3. State and explain the Coulomb's law.
4. Define electric field and electric field intensity.
5. Describe the concept of electrostatic potential.
6. Describe potential difference as energy transfer per unit charge.
7. Provide an example of when static electricity could cause harm, as well as the measures taken to prevent injury.
8. Describe how the capacitor works as a device that stores electrical charges.
9. Explain why it's important to know the effective capacitance of a number of capacitors connected in series and in parallel.
10. Give some examples of where capacitors are used in different kinds of electrical devices..
11. In what direction will a positively charged particles move in an electric field?
12. Does a series connection between capacitors always result in an equal amount of charge being stored in each capacitor?

Section (C) Numericals

1. What is the electric force of repulsion between two electrons at a distance of 1 m?
(2.3×10^{-28} N)
2. Two point charges $q_1 = 5 \mu\text{C}$ and $q_2 = 3 \mu\text{C}$ are placed at a distance of 5 cm. What will be the coulomb's force between them?
(54 N)
3. If $2 \mu\text{C}$ charge is placed in the field of 3.42×10^{11} N/C, what will be the force on it?
(684×10^3 N)
4. What is the charge on the capacitor, if a $40 \mu\text{F}$ capacitor has a potential difference of 6 V across it?
(2.4×10^{-4} C)
5. The potential difference between two points is 100 V. If an unknown charge is moved between these points, the amount of work done is 500J. Find the amount of charge. (5 C)
6. Find the equivalent capacitance when a $4 \mu\text{F}$, $3 \mu\text{F}$ and $2 \mu\text{F}$ capacitor are connected in series.
(0.92 μF)

Unit - 15

Current Electricity

Students Learning Outcomes (SLOs)

After learning this unit students should be able to

- Define electric current.
- Describe the concept of conventional current
- Understand the potential difference across a circuit component and name its unit
- Describe Ohm's law and its limitations
- Define resistance and its unit.
- Explain the underlying principles in the working of volume controls of radio and T.V
- Calculate the effective resistance of a number of resistances connected in series and also in parallel.
- Describe the factors affecting the resistances of a metallic conductor
- Distinguish between conductors and insulators
- Sketch and interpret the V-I characteristics graph for a metallic conductor, a filament lamp and a thermistor
- Describe how energy is dissipated in a resistance and explain Joule's law.
- Apply the equation $E = IVt = I^2Rt = \frac{V^2t}{R}$ to solve numerical problem.
- Calculate the cost of energy when given the cost per kWh.
- Identify circuit components such as switches, resistors, batteries, transducers, LDRs, Thermistors and capacitors, Relays and diodes, LEDs.
- Identify the symbols of circuit components and colour codes on resistors
- Construct simple series (single path) and parallel circuits (multiple paths).
- State the functions of the live, neutral and earth wires in the domestic main supply.
- Predict the behavior of light bulbs in series and parallel circuit such as for celebration lights.
- Describe the use of electrical measuring devices like galvanometer, ammeter and voltmeter (construction and working principles not required).
- Explain Alternating Current AC
- Describe hazards of electricity (damage insulation, overheating of cables, damp conditions).
- Explain the use of safety measures in household electricity, (fuse, circuit breaker, earth wire).
- Describe the damages of an electric shock from appliances on the human body.

wireless electricity. Wireless electricity is the transfer of power from one device to another, air being the medium of transmission. First attempt of wireless power transmission was made by Nikola Tesla. In the year 1899, Nikola Tesla first made practical demonstrations of wireless power transmission. He powered a field of fluorescent lamps which were located twenty-five miles away from their power source and that too without using wires.

Explanation of principles involved
This demonstrates the idea of a magnetic field being used as a source of electricity for a light bulb. The tesla coil serves as the electric source. The magnetic field that is being emitted from the tesla coil causes the electrons to move inside the bulb, eventually splitting releasing energy causing the bulb to be lit.



Do You Know!

Current is a tensor quantity because its having direction but not obeys law of vector addition.



Do You Know!



André-Marie Ampère (20 January 1775 – 10 June 1836) was a French physicist, mathematician.

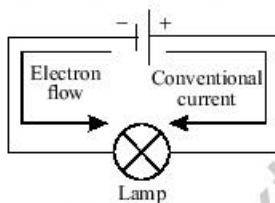

Figure 15.1

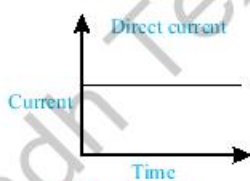

Figure 15.2

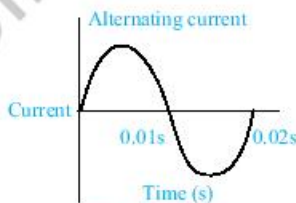

Figure 15.3

Electricity is one of the most important branch of physics. Electricity has many uses in our daily life. It is used for lighting rooms, working fans and domestic appliances like using electric stoves, air condition and more. All these provide comfort to people. In factories, large machines are worked with the help of electricity.

Modern means of transportation and communication have been revolutionised by it. Electric trains and electric cars are quick means of travel. Electricity plays a pivotal role in the fields of medicines and surgery too such as X-ray, ECG. The use of electricity is increasing day by day.

15.1 ELECTRIC CURRENT

A current is motion of any charge moving from one point to another point. An electric current is always considered as flow of negative charges of the conductor. An electric current is symbolized by I. The symbol I was used by the French physicist “Andre-Marie Ampere”. The unit of electric current (ampere) is named after him. Current always flow in circuit or electrical system.

Electronic current: When current flow from the negative terminal to the positive terminal of battery.

Conventional current: When current flows from the positive terminal to the negative terminal of battery.

Equation: $I = \frac{q}{t} \quad \therefore [q = ne]$

There are two types of electric current

- i. Direct current (DC)
- ii. Alternating current (AC)

i. Direct Current (DC)

A current that always flows in one direction only is called direct current. The current we get from a battery is a direct current.

ii. Alternating Current (AC)

A current that reverses its direction periodically is called alternating current. Most power stations in our country produce alternating current. AC changes direction every 1/50 second and its frequency is 50 Hertz (Hz).

One advantage of AC over DC is that it can be transmitted over long distances without much loss of energy.



SELF ASSESSMENT QUESTIONS

Q1: Calculate the current if 20C charges passing through a conductor in 5 Sec?

Q2: What is Analogue of flow of current?

Q3: What is the frequency of DC?

15.2 POTENTIAL DIFFERENCE

When a charge moves through a potential difference, electrical work is done and energy transferred. The Potential difference is the difference in the amount of energy that charge carriers have between two points in a field. The potential difference can be calculated by using the equation:

Equation of electric potential difference:

$$\Delta V = \frac{W}{q_0}$$

$$\therefore \Delta V = V_B - V_A$$

$$V_B - V_A = \frac{W}{q_0}$$

It can also be calculated by the equation

Potential difference is measured in volt. Volts is denoted by V.

$$\text{Volt} = \frac{\text{Joule (J)}}{\text{Columb (C)}} = \frac{\text{J}}{\text{C}} = \text{V}$$

15.2 ELECTROMOTIVE FORCE

The amount of energy required to move the charge from lower potential to higher potential of the battery is called EMF.

$$\text{Equation: EMF}(\epsilon) = \frac{\text{energy supplies (W)}}{\text{unit charge (q)}}$$

S.I unit of EMF is volt.

In centimeter-gram-second system the unit of EMF is the Statvolt or one erg per electrostatic unit of charge.

15.3 OHM'S LAW.

In 1826, George Simon Ohm made an investigation of the relation between potential difference across a conductor and the current flowing through it.

Do You Know!

The magnitude of AC and DC if same so, DC is more dangerous..

Do You Know!

Potential difference is also called voltage.

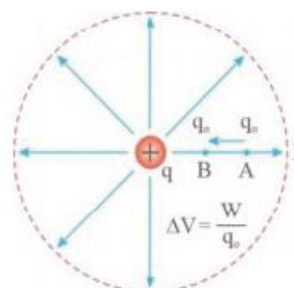
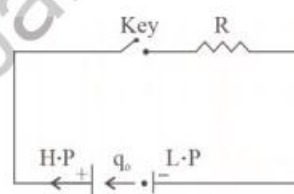

Fig: 15.4
Potential difference

Do You Know!

Production of DC is more expensive then AC

Do You Know!

The (K) in the ohm's law indicated the conductance and its unit is mho

Symbol: Ω^{-1}



Do You Know!

In graph a independent term always on x – axis and dependent term on y – axis.

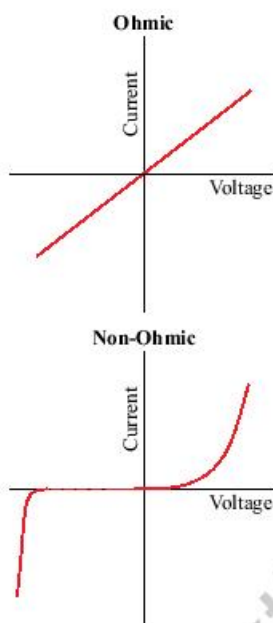

Fig: 15.5
V-I Graph of Ohmic and non-ohmic conductors

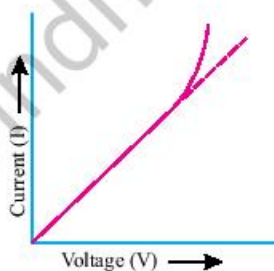

Fig: 15.6
IV characteristics

“The current flowing through the conductor is directly proportional to the potential difference (V) across the two ends of a conductor, provided the physical state (Dimension, Temperature, etc) of the conductor remain same.

Mathematically can be written as $I \propto V$

$I=KV$ where K is constant of proportionality called conductance or physical state of conductor. Conductance is opposite to resistance. Thus ($K=1/R$).

$$I=V/R \text{ rearranging the equation}$$

$$V=IR$$

Ohm’s Law is valid only for ohmic substance at a given temperature and for steady currents.

$V = IR$ where R is a constant called resistance R depends on the dimensions of the conductor and also on the material of the conductor. Its SI unit is Ohm (Ω).

Ohm’s law was found out by various experiments, somewhat similar to the thermodynamic laws. As far as its significance is concerned, this law is used within all branches of electronic studies or science. The law is useful in carrying out calculations such as in determining the value of resistors or the current in a circuit and in measuring the voltage.

Ohm’s law Limitations

There are some limitations to Ohm’s law. They are as follows:

- Ohm’s law is an empirical law which is found true for maximum experiments but not for all.
- Some materials are non-ohmic under a weak electric field.
- Ohm’s law holds true only for a conductor at a constant temperature because resistivity changes with temperature.
- As long as the current flows, greater will be the temperature of the conductor.
- Heat produced in a conductor can be calculated by Joule’s heat law $H = I^2Rt$ where I is current, R is resistance and t is time.
- Ohm’s law is not applicable to in-network circuits.



- Ohm's does not apply directly to capacitor circuits and Inductor circuits.
- V-I graph of ohmic conductors is not really a straight graph. It does show some variation.
- The V-I characteristics of diodes are much different from ohmic conductors V-I graph.

Worked Example 1

How much voltage will be dropped across a $50\text{ k}\Omega$ resistance whose current is $300\text{ }\mu\text{A}$?

Solution:

Step 1: Write down the known quantities and quantities to

$$R = 50\text{ k}\Omega = 50 \times 10^3\Omega$$

$$I = 300\text{ }\mu\text{A} = 300 \times 10^{-6}\text{ A}$$

$$V = ?$$

Step 2: Write down the formula and rearrange if necessary.

$$V = I \times R$$

Step 3: Put the values and calculate.

$$V = I \times R$$

$$V = (300 \times 10^{-6}) \times (50 \times 10^3)$$

$$V = 15\text{ V}$$

Result: $V = 15\text{ V}$

SELF ASSESSMENT QUESTIONS

Q1: The Product of resistance and capacitance equal to?

15.4 RESISTANCE

The electrical resistance of a circuit is the ratio between the voltage applied to the current flowing through it. According to Ohm's law, there is a relation between the current flowing through a conductor and the potential difference across it. It is given by,

$$R = \frac{V}{I}$$

Where V is the potential difference measured across the conductor (in volt), I is the current (ampere), R is the constant of proportionality, is called resistance (ohms)

The unit of electrical resistance is ohms.

$$R = \frac{V}{I} = \text{ohm} = \frac{1\text{ volt}}{1\text{ ampere}}$$

Electric charge flows easily through some materials

Do You Know!

The device that does not follow ohm's law is known as a **non-ohmic device**

Examples of non-ohmic devices are **thermistors, crystal rectifiers, vacuum tube, diode** etc.



Diode



Thermistor



Vacuum tube



Fig: 15.7
Resistor

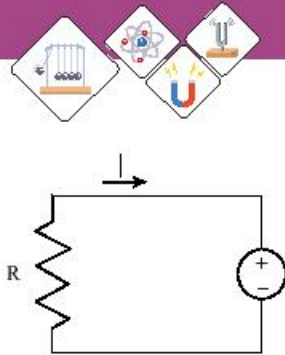
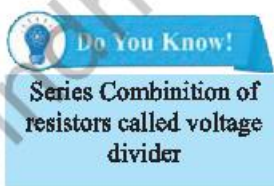
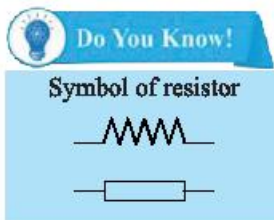

Fig: 15.8



than others. The electrical resistance measures how much the flow of this electric charge is restricted within the circuit.

Factor affecting the resistance

Electrical resistance is directly proportional to length (L) of the conductor and inversely proportional to the cross-sectional area (A). It is given by the following relation.

$$R = \rho L/A$$

where ρ is the resistivity of the material measured in Ωm , (ohm-meter)

Resistivity is a qualitative measurement of a material's ability to resist flowing electric current. Obviously, insulators will have a higher value of resistivity than that of conductors.

Electrical resistance is inversely proportional to the temperature of metallic conductor because the random motion of free electron increased and offers more resistance in a metallic conductor.

Uses of Resistance

Resistance is also useful in things like transistor radios and TV sets. Suppose you want to lower the volume on your TV. You turn the volume knob and the sound gets quieter but how does that happen? The volume knob is actually part of an electronic component called a variable resistor. If you turn the volume down, you're actually turning up the resistance in an electrical circuit that drives the TV's loudspeaker. When you turn up the resistance, the electric current flowing through the circuit is reduced. With less current, there's less energy to power the loudspeaker—so it sounds much quieter.

15.5 SERIES AND PARALLEL COMBINATIONS OF RESISTORS IN A CIRCUIT

The method of connect the electric components is called circuit.

There are two types of circuits

- (1) Series Combination circuit
- (2) Parallel Combinations circuit



Series combination circuits:

When resistors are connected end to end such that there is only one path for the current to flow then the combination is called series combination.

Let suppose three resistors R_1 , R_2 and R_3 are connected in Series, when this combination is connected to a battery of V volts, it draws current I from the battery. R_e is a single resistor. This resistor is such that when it is connected to the same battery of V volts, it also draws current I from the battery. This resistor is therefore called equivalent resistor and its resistance is called equivalent resistance.

$$V = V_1 + V_2 + V_3$$

By applying Ohm's Law to each resistor. We have:

$$V_1 = IR_1, V_2 = IR_2, V_3 = IR_3, V = IR_e.$$

Using them in equation we get:

$$IR_e = IR_1 + IR_2 + IR_3.$$

$$IR_e = I (R_1 + R_2 + R_3).$$

$$R_e = R_1 + R_2 + R_3$$

Thus equivalent resistance is equal to the sum of individual resistance.

Advantages:

1. It's employed when a large number of bulbs or lights need to be used at the same time.
2. Because the circuit receives less current, it is safer.
3. Because all the bulbs, lights, and appliances are connected together, it's easier to turn them on or off.

Disadvantages:

1. Because all electrical appliances have only one switch, no single appliance may be turned off separately.
2. The second component of the circuit will not function if one component is fused or quits operating.
3. Because the voltage is distributed in series or combinations, not all of the components receive the same voltage.

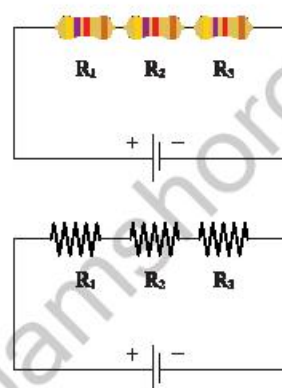

Fig: 15.9
Diagram showing
three resistors
connected in series



Weblinks

Encourage students to visit below link for Resistor in series combination circuit

https://www.youtube.com/watch?v=pd3RkGs1Tsg&ab_channel=Don%27tMemorise



Worked Example 2

Find the current I passing through circuit and the voltage across each of the resistors in the circuit below. Resistors in series.

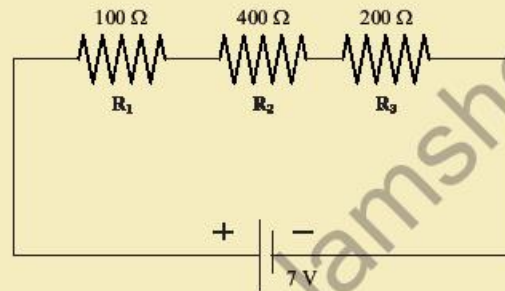

Weblinks

Encourage students to visit below link for How to find current and voltage of resistor in series
https://www.youtube.com/watch?v=EsNsAZ8PR4E&ab_channel=VAM%21Physics%26Engineering

Solution:

Step 1: Write down the known quantities and quantities to be found. The three resistors in series have a resistance R_e given by the sum of the three resistances. Hence

$$R_e = 100 + 400 + 200 = 700 \Omega$$

Step 2: Write down the formula and rearrange if necessary.

$$I = \frac{V}{R}$$

Step 3: Put the values and calculate.

$$I = \frac{V}{R}$$

$$I = \frac{7V}{700\Omega} = 0.01A$$

The voltage across each resistance is calculated using Ohm's law as follows:

$$V = IR_1 = 100 \times 0.01 = 1 \text{ V}$$

$$V = IR_2 = 400 \times 0.01 = 4 \text{ V}$$

$$V = IR_3 = 200 \times 0.01 = 2 \text{ V}$$

Result: $I = 0.01 \text{ A}$, $V = 1 \text{ V}$, 4 V , 2 V

Parallel combination circuits:

When there are multiple paths for current flow in a circuit (as indicated in the diagram), the combination of resistances is referred to as parallel combination. Each resistor's potential is the same and equal to the applied potential.

Each resistor has a steady current flowing through it. In



Weblinks

Encourage students to visit below link for Parallel arrangement of resistors
https://www.youtube.com/watch?v=BbYtMQ8EYBg&ab_channel=7activestudio



homes, the parallel combination is used for various domestic appliances, each of which has its own switch that may be turned on or off as needed.

Let suppose three resistors R_1 , R_2 and R_3 are connected in Parallel. When the combination is connected to a battery of V volts, it draws a current I from the battery.

R_e is a single resistor. This resistor is such that when it is connected to the same battery of V volts, it also draws current I from the battery. This resistor is therefore called equivalent resistor and its resistance is called equivalent resistance.

$$I = I_1 + I_2 + I_3$$

By applying Ohm's Law to each resistor. We have:

$$V = I_1 R_1, V = I_2 R_2, V = I_3 R_3, V = I R_e$$

$$I_1 = \frac{V}{R_1}, I_2 = \frac{V}{R_2}, I_3 = \frac{V}{R_3}, I = \frac{V}{R_e}$$

Using them in equation, we get:

$$\begin{aligned} \frac{V}{R_e} &= \frac{V}{R_1} + \frac{V}{R_2} + \frac{V}{R_3} \\ \frac{V}{R_e} &= V \left(\frac{1}{R_1} + \frac{1}{R_2} + \frac{1}{R_3} \right) \\ \frac{1}{R_e} &= \frac{1}{R_1} + \frac{1}{R_2} + \frac{1}{R_3} \end{aligned}$$

Thus the reciprocal of equivalent resistance is equal to the sums of reciprocals of individual resistances.

If one component of the circuit or a resistor is destroyed in parallel combinations of resistors, the remaining components of the circuit will continue to function normally. It's due to the fact that there are multiple paths for electric current to go through.

Worked Example 3

Find current I in the circuit below and the current passing through each of the resistors in the circuit. Resistors in parallel in example 2.

Solution:

The three resistors are in parallel and behave like a resistor with resistance R_{eq} given by

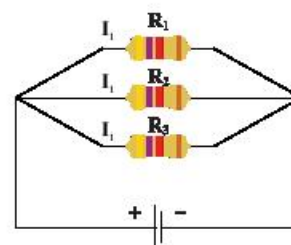
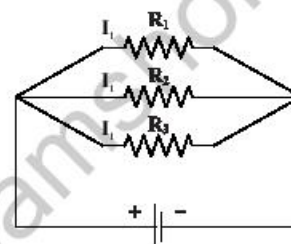
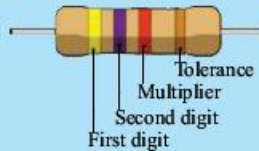

Fig: 15.10
Three resistors
connected in parallel



Do You Know!

Colours coding of resistors



1st digit	2nd digit	Multiplier	Tolerance
0	0	$\times 1$	Silver $\pm 10\%$
1	1	$\times 10$	Gold $\pm 5\%$
2	2	$\times 100$	
3	3	$\times 1000$	
4	4	$\times 10000$	
5	5	$\times 100000$	
6	6	$\times 1000000$	
7	7		
8	8		
9	9		

Yellow	Violet	Orange	Gold
4	7	$\times 1000$	$\pm 5\%$

47K Ω $\pm 5\%$



Do You Know!

To calculate the kWh for a specific appliance, multiply the power rating (watts) of the appliance by the amount of time (hrs) you use the appliance and divide by 1000.

Usually listed on the power cord, this is the rated power your appliance uses when turned on

Time appliances in "on" if minutes or seconds, convert to hours first

$$Kwh = \frac{\text{Watts} \times \text{times (hrs)}}{1000}$$

Kilo-Watt-hour is what you are billed for by the utility company.

Need to divide the total by 1000 otherwise it would be wh, not 'Kil-Wh'

$$1 / R_e = 1 / 100 + 1 / 400 + 1 / 200$$

Multiply all terms by 400 and simplify to obtain

$$400 / R_e = 4 + 1 + 2$$

Solve for R_e to obtain

$$R_e = 400 / 7 \Omega$$

The main current I is given by

$$I = 7 / R_e = 7 / (400 / 7) = 49 / 400 \text{ A}$$

We now use Ohm's law to find the current passing through each resistor.

The current through the resistor of 100 Ω : $I_1 = 7 / 100 \text{ A}$

The current through the resistor of 400 Ω : $I_2 = 7 / 400 \text{ A}$

The current through the resistor of 200 Ω : $I_3 = 7 / 200 \text{ A}$

As an exercise; check that the sum of the three currents above is equal to the current $I = 49 / 400 \text{ A}$.

Advantages:

1. Each appliance can be turned on or off independently.
2. The voltage of each electrical appliance is the same as the power supply line.
3. If one electrical appliance stops working due to a problem, the other appliances will continue to function.

Disadvantages:

1. Because the circuit can carry higher current, it is less safe.
2. If hundreds of appliances or lamps need to be turned on or off at the same time, this method is difficult to apply.

15.7 ELECTRICAL POWER AND JOULE'S LAW

Electric Power

The rate at which the work is being done in an electrical circuit is called an electric power.

or

The rate of the transfer of energy.

When a current flows through a resistor, electrical energy is converted into HEAT energy. The heat generated in the components of a circuit, all of which possess at least some resistance, is dissipated into the air around the components.

The rate at which the heat is dissipated is called **power dissipation**



It is denoted by P and measured in units of Watts (W)
Mathematically equation of power dissipation and resistors.

$$P = IV = I^2R = \frac{V^2}{R}$$

Energy in Resistors

ENERGY is dissipated when a particular amount of power is dissipated over a period of time. Energy (power × time) is measured in Joules, and the energy dissipated by a component or circuit can be estimated by including time (t) in the power formulas.

Energy dissipated = Pt or VIt or V^2t/R or even I^2Rt Joules

Joule's law

When an electric current flows through a circuit, it increases the internal energy of the conductor, which gives rise to the collision of electrons with atoms of the conductor, and which results in heat generation. To measure the amount of heat generated due to these collisions, Joule, an English physicist, gave the Joule's law. when an electric current passes through a conductor, heat H is produced, which is directly proportional to the resistance R of the conductor, the time t for which the current flows, and to the square of the magnitude of current I.

Mathematically it is represented as $H \propto I^2 \cdot Rt$.

The joule's first law shows the relationship between heat produced by flowing electric current through a conductor.

$$H = I^2 Rt$$

Where, H indicates the amount of heat, I show electric current, R is the amount of electric resistance in the conductor, t denotes time

The amount of generated heat is proportional to the wire's electrical resistance when the current in the circuit and the flow of current is not changed.

The amount of generated heat in a conductor carrying current is proportional to the square of the current flow through the circuit when the electrical resistance and current supply is constant.

The amount of heat produced because of the current flow is proportional to the time of flow when the resistance and current flow is kept constant.

Do You Know!

Applications of Joule's law

The heating effect of electric current is used in some electrical equipment such as the electric iron, electric toaster, and electric heater. In many electrical devices, Nichrome (an alloy of nickel and chromium) is employed as a heating element. This is due to the following factors:

Nichrome possesses a high level of specific resistance.

The melting point of nichrome is extremely high.

Nichrome is resistant to oxidation.





Weblinks

Encourage students to visit below link for Verification of Joule's law

https://www.youtube.com/watch?v=93AVPN747O8&ab_channel=Physics4students



Weblink

Encourage students to visit below link for Current and potential difference

https://www.youtube.com/watch?v=cYifAaTFe8A&ab_channel=FuseSchool-GlobalEducation

Worked Example 4

100J of heat is produced each second in a $4\ \Omega$ resistance. Find the potential difference across the resistor.

Solution:

Step 1: Write down the known quantities and quantities to be found

$$\begin{aligned} H &= 100\text{J} \\ t &= 1\text{s} \\ R &= 4\ \Omega \\ V &=? \end{aligned}$$

Step 2: Write down the formula and rearrange if necessary.

$$\begin{aligned} H &= I^2 R t \\ V &= IR \\ \frac{V}{R} &= I \\ I &= \frac{V}{R} \\ H &= \left(\frac{V}{R}\right)^2 \times R t \\ H &= \frac{V^2}{R^2} \times R \times t \\ H &= \frac{V^2}{R} \times t \end{aligned}$$

Step 3: Put the values and calculate.

$$\begin{aligned} 100 &= \frac{V^2}{4} \times 1 \\ 100 \times 4 &= V^2 \\ 400 &= V^2 \\ V^2 &= 400 \\ V &= \sqrt{400} \\ V &= 20\text{V} \end{aligned}$$

Result: Potential difference is 20V.



15.8 USE OF CIRCUIT COMPONENTS

Electrical components and their uses

The devices that make up an electronic circuit are known as electronic components. They're made to be joined together, usually by welding, to form a circuit on a circuit system. Semiconductors, active, passive, optoelectronic, electromagnetic, and other types of components can be classified.

Switches or key: It is one of the most fundamental electrical components, it is used to turn electric circuits ON and OFF. This simply implies that when you press or flick a switch, current is allowed to pass through to the rest of the circuit.

Resistor: It is a two-terminal electrical component that implements electrical resistance as a circuit element.

Battery: It is electrical source that store the chemical energy and converts the chemical energy into electrical energy.

Transducer: It is an electrical component that converts one form of energy into another form of energy like microphone converts sound energy into electrical energy/signal as shown in figure 15.14.

LDRs (Light Dependent Resistors):

A photoresistor or light dependent resistor is an electronic component that is sensitive to light.

For example, in automatic security lights. Their resistance decreases as the light intensity increases

- In low light levels, the resistance of an LDR is high and little current can flow through it.
- In bright light, the resistance of an LDR is low and more current can flow through it.

Thermistors

It is thermally sensitive resistors whose resistance is strongly dependent on temperature. It is used to measure the temperature very accurately.

Relay: It switches which aim at OFF and ON the circuits electronically as well as electromechanically.

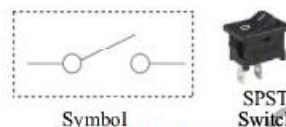

Fig: 15.11
Switch or key



Fig: 15.12
Resistor



Fig: 15.13
Battery

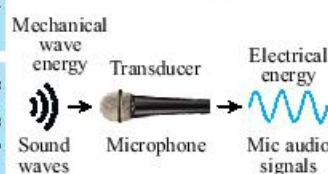

Fig: 15.14
Transducer

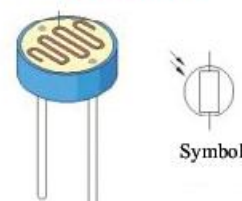

Fig: 15.15
Light dependent resistor (LDR)



Fig: 15.16 Thermistor

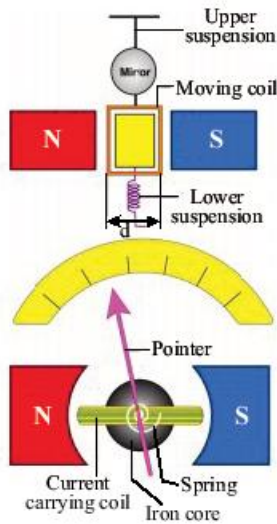
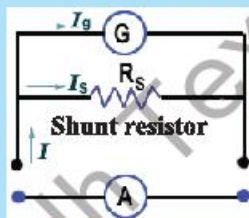

Fig: 15.17
Galvanometer



Do You Know!

A resistor having a very low value of resistance such type of resistor is called **shunt resistance**.



Do You Know!

A voltmeter using in a circuit parallel. Symbol of voltmeter is

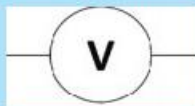

Moving coil galvanometer:

It is an electromechanical instrument used to detect and measures small amount of current which is in the range between milli amperes or micro amperes.

Luigi Galvano invented this device so it belongs to his name. this is a current detecting meter based on magnetic dipole torque.

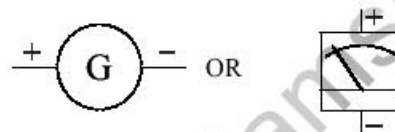

Ammeter:

An Ammeter is an Electromechanical instrument used to measure electric current. It is a modified form of Galvanometer. A Galvanometer can be converted into an Ammeter by connecting a low shunt resistance in parallel to the Galvanometer. A Ammeter using in a circuit always in "Series" Its symbol is (A)



Fig: 15.18 Ammeter

Voltmeter:

Voltmeter is an Electromechanical Instrument used to measure potential difference. A Galvanometer can be converted into a Voltmeter if a high resistance is connected in Series with Galvanometer.



Fig: 15.19
Voltmeter

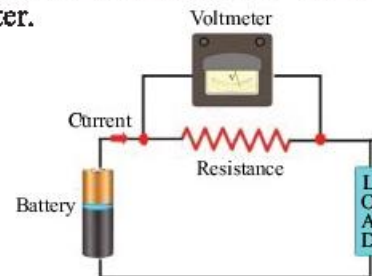

Fig: 15.20 circuit diagram of voltmeter



Electrical Power transmission to a house

There are three cables that provide electricity into the building. One is referred to as a **ground wire** or **earth wire (E)**. There is no current through this. The house's earth wire is connected to a buried metal plate. The other cable, known as a **neutral wire**, is grounded to the Earth within the power plant itself to keep its voltage constant (N). The current flows back through this wire. The third wire, which has a high potential and is called the **livewire**, is connected to the battery (L). Difference in voltage between the live and neutral wires is 220V.

The human body is a good conductor of electricity. If a person holds livewire, current will flow to the ground through his body, which could be dangerous. The live and neutral wires are used to connect all of the equipment in a home. All have the same potential difference, thus they're joined in parallel to the power source.

A connection has been made between the cables coming from the mains and the electricity meter that has been installed in the residence as shown in the figure 15.9 The electric meter's output goes to the main distribution board and subsequently the home electric circuit.

The main box has fuses with ratings of about 30 A. Each appliance has its own connection made directly to the live wire. A fuse and a switch are used to connect the appliance terminal to the livewire. In the event that the fuse of one appliance blows, it will not have any impact on the functioning of the other appliances.

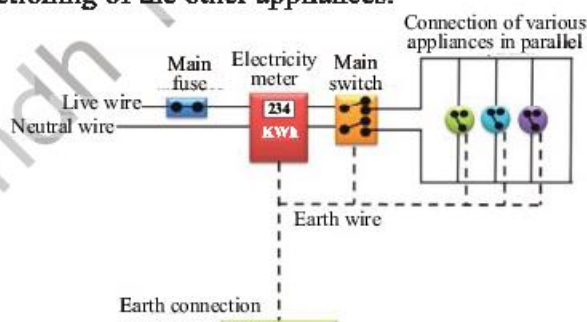

Fig: 15.21

Illustrate the distribution of electrical power from main to the home appliances



Weblinks

Encourage students to visit below link for Live, neutral and earth wire

https://www.youtube.com/watch?v=0OKTejgaWTY&ab_channel=FuseSchool-GlobalEducation



Weblinks

Encourage students to visit below link for How electricity reaches out home

https://www.youtube.com/watch?v=nBM1kd_ECog&ab_channel=GauravJ-TheElectricalGuy



Hazards of electricity

Electrical shock, fire, and arc flashes are the primary hazards that are present when working with electricity. When the human body comes into contact with either or both of the wires in an electrical circuit or with one wire of an energized circuit and the ground, or with a metallic part that has become energized by contact with an electrical conductor, the result is an electric shock.

Electrical shock severity depends on the pathway through the body, the amount of current, the length of exposure, and whether the skin is wet or dry. Wet skin and wet conditions are good conductors of electricity.



Fig: 15.22
Damaged Insulation

Damaged Insulation:

Insulation refers to the sheath made of plastic that is wrapped around wires in a circuit. If the insulation on a cable is damaged, the metal conductors inside will be exposed.

It is possible for a person to receive an electric shock if they come into contact with the exposed wires, which could result in their death. Before replacing any damaged insulation attempting to cover any damaged insulation with electrical tape, make sure that all power sources have been turned off and then replace the damaged insulation.



Fig: 15.23
Over heating of a cable

Overheating of cables:

When a very high current is passed through a cable, there is a possibility that the wire will overheat as a result of the excessive amount of energy. Because of the overheating, there is a risk of electrical fires.

Damp conditions:

People who are in close proximity to an electrical appliance that is being used in a damp environment, such as a bathroom, have an increased risk of being electrocuted by the electricity that is being conducted through the water because water is a conductor. If a person touches a socket while their skin is wet in any way, they run the risk of being electrocuted.



Fig: 15.24
Electrical extension placed damped environment

Safety measures in household electricity

Electricity as a power source has become very crucial to the functioning of modern society. Despite its usefulness, there



are a number of potential electrical hazards and mishaps that must not be ignored. If not handled carefully, this constant stream of electrons can destroy any living tissue it comes into contact with. To avoid any unwanted incident few measures must be taken which are given below:

Fuses and Breakers

Circuit breakers, or fuses, prevent damage to electronics components caused by overheating. When there is a significant amount of current running through the circuit, the wires that are contained within the circuit will begin to overheat. A metal wire fuse with a low melting point will become molten, breaking the circuit.

The Circuit-Breaker

In the majority of applications found in the home, circuit breakers are used to restrict the amount of current flowing through a single circuit. Although circuit breakers are available in a wide range of sizes, the maximum current that can flow through a single circuit is typically 20 amps. 20 amps of current will heat the bimetallic strip, bending it downward and releasing the trip-lever. To manage the large surges that result from a short circuit, a different mechanism is utilized due to the relatively slow heating. In the case of a high-current spike, the bimetallic strip will be rapidly retracted by a small electromagnet made from wire loops wrapped around a piece of iron.

The Ground Wire

The word "ground" means that something is connected to the earth, which stores charge. A ground wire gives an electrical appliance a path to the earth that is separate from the normal path that current takes. As a practical matter, it is connected to the electrical neutral at the service panel so that if there is an electrical fault, there is a path with low enough resistance to trip the circuit breaker as illustrated in figure 15.23. Attached to an appliance's case, it keeps the case's voltage at ground potential (usually taken as the zero of voltage). In this way, electric shock is prevented. Standard electric circuits have a ground wire and either a fuse or a circuit breaker for safety.



Fig: 15.25
Different type of fuse
used in electronic
component



Fig: 15.26 (a)
Circuit breaker

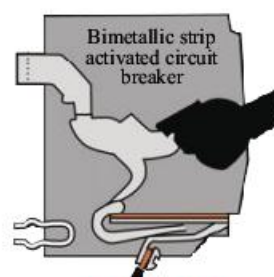

Fig: 15.27 (b)
Schematic diagram of
circuit breaker

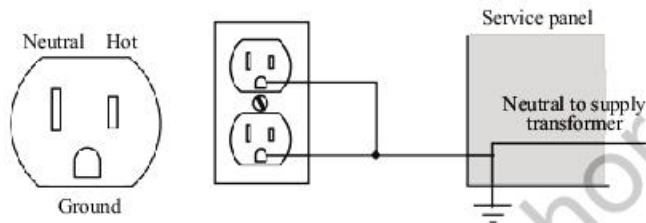

Fig: 15.28 Electric circuit having ground wire

Effects of electric shock on human body

- Electric current of 0.001 A can be felt
- Electric current of 0.005 A, can be painful for human body.
- If electric current is of 0.010 A, resulting in the contraction of muscles in an uncontrollable manner (spasms)
- Electric shock of 0.015 A can leads to a lack of control over the muscles.
- The electric current of 0.070 A passes through the heart; creates a significant disturbance; and is almost certainly fatal if the current continues for more than one second.

SELF ASSESSMENT QUESTIONS

- Q1:** Explain briefly the dangers of electricity in the home.
- Q2:** Give four safety precautions that should be taken with the household circuit.
- Q3:** In a circuit, does the fuse regulate the voltage or the current?



Weblinks

Encourage students to visit below link for Why don't birds get electrocuted on power lines?

https://www.youtube.com/watch?v=rtnmCf2QFTc&ab_channel=InterestingEngineering



SUMMARY

- **Steady current:** The continuous flow of free electrons.
- Electric current is the net charge flowing through the cross-section area A per unit time. $I=Q/t$
- **Direct Current (DC)** is current flows in one direction with constant magnitude.
- **Alternating Current (AC)** is an electric current that reverses its direction many times a second at regular intervals.
- The difference of electrical potential between two points is known as Potential Difference.
- **Electromotive force (Emf)** is the energy per unit electric charge that is imparted by an energy source, such as an electric generator or a battery
- **Ohm's law** states that the magnitude of the current flowing through conductor is directly proportional to the potential drop across the ends of conductor as long as the physical state of the conductor is kept constant. ($V = IR$)
- **Conductance** is the reciprocal of resistance of a conductor.
- In series combination of resistors, the Equivalent resistance is equal to sum of individual resistors.
- In Parallel Combination of resistors, the reciprocal of resistance is equal to the sum reciprocals of individual resistances.
- Electric power is the rate at which work is done in an electric circuit.
- **Joule's Law** state that The rate at which heat is produced by a steady current in any part of an electric circuit is jointly proportional to the resistance and the square of the current
- **Thermistor** is a heat sensitive device usually made of a semiconductor material whose resistance changes very rapidly with change of temperature.
- **Relay** is a device that opens or closes the contacts to cause the operation of the other electric control.
- **Light-Emitting Diode (LED)** is a semiconductor light source that emits light when current flows through it.
- **Light dependent resistors (LDRs)** or photo-resistors are electronic components that are often used in electronic circuit designs where it is necessary to detect the presence or the level of light.
- **Galvanometer** is an electrical instrument used to measure and detect small current.
- **Ammeter** is an electrical device used to measure the electric current in Amperes (A) or mili-ampere (mA).
- **Voltmeter** is an electrical device used to measure the potential across the two ends.



CONCEPT MAP

Current Electricity

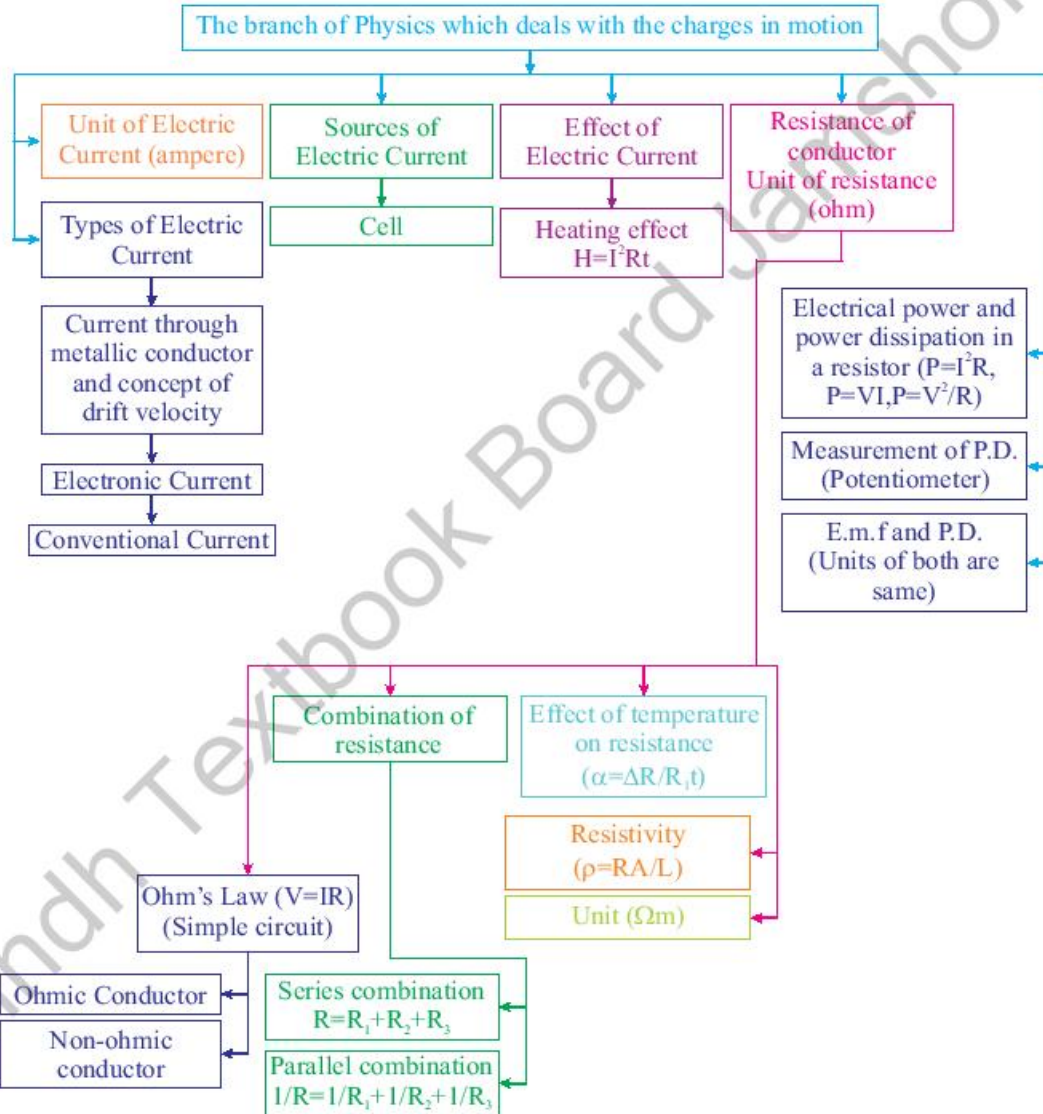



Section (A) Multiple Choice Questions (MCQs)

- In an Electric circuit when Electrons move from low to high potential they will:
(a) Gain Energy (b) Lose their identity
(c) Lose Energy (d) Gain Potential
- In an electric circuit an ammeter is always connected in
(a) Series (b) parallel
(c) mixed (d) none of the above
- Resistance of a conductor does not depend on
(a) Length of the conductor (b) Area of cross-section
(c) Density (d) Resistivity
- Ohm's law states that:
(a) Resistance increases as current increases
(b) Resistance decreases as current increases
(c) Resistance increases as voltage increases
(d) Current increases as voltage increases
- The condition when the resistance of a circuit is zero is known as
(a) Closed-circuit (b) Open circuit
(c) Short circuit (d) Zero circuit
- The condition for the validity of Ohm's law is that the
(a) Temperature should remain constant
(b) Current should be proportional to voltage
(c) Resistance must be wire wound type
(d) All of the above
- Ohm's law is not applicable to
(a) Semiconductors (b) D.C. circuits (c) Small resistors (d) High currents
- Two resistances of $6\ \Omega$ and $12\ \Omega$ are connected in parallel. Their net resistance is _____.
(a) $7\ \Omega$ (b) $6\ \Omega$ (c) $4\ \Omega$ (d) $5\ \Omega$
- The property of a body to oppose the flow of electric charge through it is called electric _____.
(a) Capacitance (b) potential
(c) resistance (d) conductance
- Which of the following is the purpose of connecting a battery in an electric circuit?
(a) To maintain resistance across the conductor.
(b) To vary resistance across the conductors.
(c) To maintain constant potential difference across the conductor.
(d) To maintain varying potential difference across the conductor.



Section (B) Structured Questions

1. Is it always the case that a series connection between capacitors will result in an equal amount of charge being stored in each capacitor?
2. Why should we connect the equipment in parallel rather than in series, and what are the benefits of this configuration?
3. Does a circuit need a potential difference in order for current to flow through it?
4. It is impracticable to connect an electric blub and an electric heater in series. Why?
5. When a fuse is used in a circuit, does it control the current or the potential difference?
6. Explain what you mean by the term "conventional current"
7. Describe Ohm's law and its limitations
8. Determine the effective resistance of a number of resistances that are connected in either series or parallel by doing the appropriate calculations.
9. Explain what influences the resistance of a metal conductor and how you measured it.
10. Explain Joule's law and the process of energy dissipation in a resistance.
11. Explain the roles of the live, neutral and earth wires in a standard home electrical system.
12. How Does AC Work?
13. Explain the risks associated with electrical current (damage insulation, overheating of cables, damp conditions).
14. Explain how safety precautions are used in home electricity.
15. Describe the effects of an appliance-caused electrical shock on the human body.
16. Why the voltage used for the domestic supply much lower than the voltage at which the power is transmitted?



Section (C) Numericals

1. When the current in a pocket calculator is 0.0002 A, how much charge flows every minute? **(12mC)**
2. Calculate the amount of current that an electric heater uses to heat a room in 5 minutes if the charge is 2100 C. **(7 A)**
3. A potential difference of 90 V exists between two points. The amount of work done when an unknown charge is moved between the points is 450J. Determine the charge amount **(5 C)**
4. Calculate the potential difference between two points A and B if it takes 9×10^{-4} J of external work to move a charge of $+9 \mu\text{C}$ from A to B. **(100 V)**
5. The potential difference applied to a portable radio terminal is 6.0 Volts. Determine the resistance of the radio when a current of 20 mA flows through it. **(300 Ω)**
6. Resistances of 4 Ω , 6 Ω , and 12 Ω are connected in parallel and then connected to a 6V emf source. Determine the value of
 - i. The circuit's equivalent resistance. **(2 Ω)**
 - ii. The total current flowing through the circuit. **(3 A)**
 - iii. The current that flows through each resistance. **(1.5 A, 1 A, 0.5 A)**
7. A 220 V circuit is used to power two 120 watt and 80 watt light bulbs. Which bulb has the greater resistance and which one has the higher current?
(80 W bulb, 120 W bulb)

Unit - 16

Electromagnetism

Students Learning Outcomes (SLOs)

After learning this unit students should be able to

- Explain by describing an experiment that an electric current in a conductor produces a magnetic field around it.
- Define Magnetic field
- Sketch the lines of magnetic force
- Describe that a force acts on a current carrying conductor placed in a magnetic field as long as the conductor is not parallel to the magnetic field.
- State that a current carrying coil in a magnetic field experiences a torque.
- Relate the turning effect on a coil to the action of a D.C. motor
- Describe an experiment to show that a changing magnetic field can induce e.m.f. in a circuit.
- List factors affecting the magnitude of an induced e.m.f.
- Explain that the direction of an induced e.m.f. opposes the change causing it and relate this phenomenon to conservation of energy
- Describe a simple form of A.C generator.
- Describe mutual induction and state its units
- Identify that a transformer works on the principle of mutual induction between two coils
- Describe the purpose of transformers in A.C circuits
- Identify the role of transformers in power transmission from power station to your house.
- List the use of transformer (step-up and step-down) for various purposes in your home

There is a strong connection between electricity and magnetism. The production of electricity using a magnet as a source is an interesting occurrence. It is possible to generate electric current by changing magnetic field, and likewise, magnetic fields can be generated by changing electrical current. A simple magnet can be used to produce a life-changing technology which makes life easier.



The four fundamental forces act upon us every day, whether we realize it or not. From playing basketball, to launching a rocket into space, to sticking a magnet on your refrigerator - all the forces that all of us experience every day can be whittled down to a critical quartet: Gravity, the weak force, electromagnetism, and the strong force. These forces govern everything that happens in the universe.

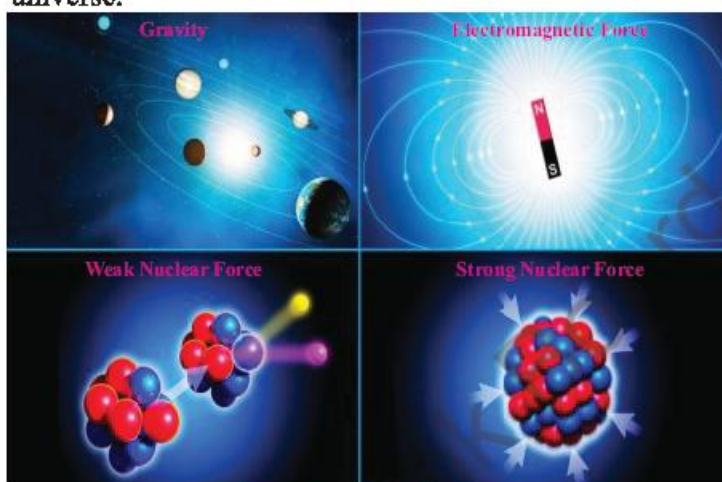

Fig: 16.1 Fundamental forces of nature

Gravity is the force that attracts matter across long distances (tens of millions of light years). The electromagnetic force is extremely powerful, but it operates at very small scales, forcing positively charged atomic nuclei to attract negatively charged electrons, resulting in the formation of atoms and molecules.

It's the fundamental reason that electrons are held by nucleus and are accountable for the nucleus entire structure.

Electromagnetism serves as a basic principle of working for many of the home appliances in household applications. These applications include lighting, air conditioning systems, Generators, transformers etc. Students will be able to understand all the above facts after completing this unit.

Do You Know!

Electromagnetic force in forming matter

Coulombs' Law

Like charges repel, unlike charges attract. Protons repel each other and the same is true for electrons, but the electromagnetic force attracts electrons to protons.



Electron Capture

The electromagnetic force pulls electrons into orbit around positively charged atomic nuclei. The larger the nuclei, the more electrons are pulled in.

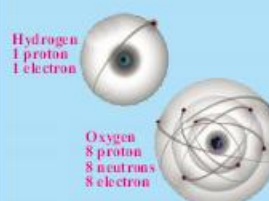

Atoms and molecules

The electromagnetic force holds atoms and molecules together. Electrons occupy energy levels around atomic nuclei balancing out positive and negative charges



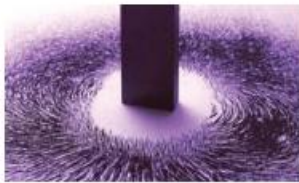

Fig: 16.2
Electromagnetic force



Do You Know!

The electromagnetic force, also called the Lorentz force, acts between charged particles, like negatively charged electrons and positively charged protons. Opposite charges attract one another, while like charges repel. The greater the charge, the greater the force.

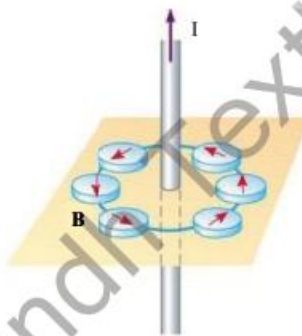

Fig: 16.4 Compasses align to reveal a circular magnetic field pattern around a current-carrying conductor.

Electromagnetic force

The electromagnetic force, as its name suggests, is consist of two forces, electric and magnetic forces. Physicists once thought of these forces as independent entities, but eventually discovered that they are parts of the same force.

The electric charge interacts with charged particles, whether they're moving or stationary, to create a field in which the charges can influence one another. When those charged particles are set in motion, however, they begin to exhibit the second component, magnetic force. As the charged particle start to move, they produce a magnetic field surrounding them as illustrated in figure 16.3. As a result, when electrons flow across a wire to charge your computer or phone, or switch ON your TV, the weak magnetic field produced around the wire.

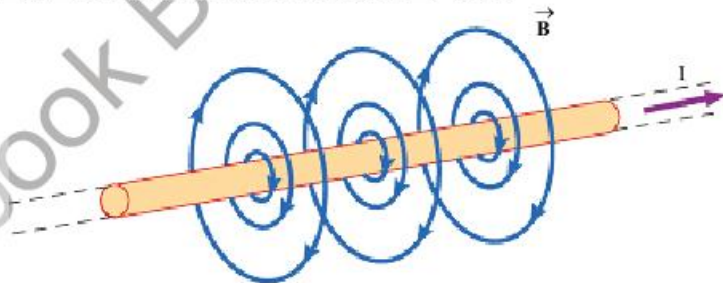

Fig: 16.3 Connection between electricity and magnetism

16.1 Magnetic effect of a steady current

You can demonstrate the magnetic field around the current-carrying conductor by doing an experiment. Pass a current-carrying conductor through a cardboard sheet. Small compasses should be placed near the conductor. Figure 16.4 shows how the compasses will point in the direction of the magnetic lines of force.

The magnetic field direction around a current-carrying conductor can be determined using the Flemings right hand rule for conductors.

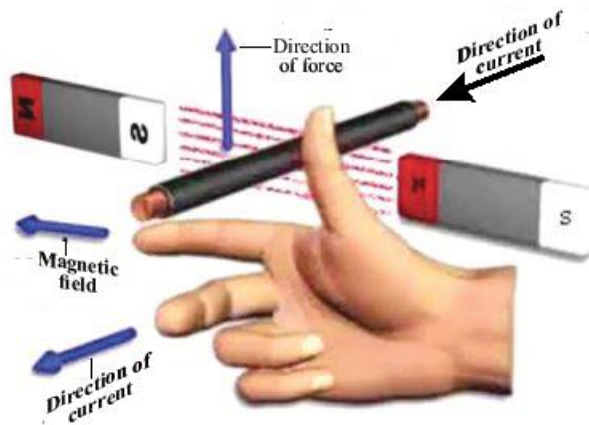

Fig: 16.5 Demonstration of the right-hand rule for conductors.

Consider the dot in the middle of the conductor on the left as the point of an arrow in Figure 16.6. This indicates that an electric current is traveling in your direction. The magnetic field's direction is indicated by circular arrows. When electrical wires carry alternating currents, this principle is important. This is due to the fact that the positioning of wires, known as lead dress, has an impact on the operation of a circuit.

When possible, conductors are grouped in pairs to reduce heating and radio interference caused by the magnetic field created by electric current flow. To help reduce this heating effect, the National Electric Code requires that wires be run in pairs.

These conventions are used to show the link between electric current flow and the magnetic field. The dot represents a current arrow heading toward you. The cross on the right represents the tail end of the current arrow heading away from you.

Magnetic field produced by current carrying conductor

When electric charges are at rest, they exert electrostatic forces of attraction or repulsion on each other. As we know that isolated moving charges produce both electric and magnetic fields, but an electric current through a conductor produces only a magnetic field

Do You Know!

When current flowing upward direction its indicated the north pole and downward direction is south pole.

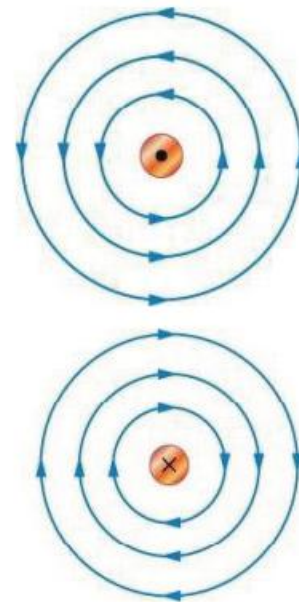

Fig: 16.6 Magnetic field produced by current



Do You Know!

Tesla is a unit of magnetic flux density in the MKS system it is equivalent to one weber per square meter.
1 Tesla = 10^4 Gauss

because the electric field of moving electrons is neutralized by the field of the fixed protons in the conductor. The magnetic field around a magnetic moving charge is a vector quantity symbolized by B.

Now suppose a particle carrying charge q is projected with speed v into a magnetic field of magnetic induction B such that the angle between B and V is θ . The magnetic field of the charged particle interacts with the magnetic field of the magnet in which it is sent, due to which a force is produced which acts upon the particle. It is found that:

- The force F acting on the particle is directly proportional to the charge q .
- The force F acting on the particle is directly proportional to the velocity V .
- The force F is directed perpendicular to the plane containing V and B .

Combining the above three observations, we found that:

$$F = q V \times B$$

So the magnitude of B is given by:

$$B = \frac{F}{qV \sin \theta} = \frac{\text{Newton}}{\text{Coulomb} \times \text{m/sec}} = \frac{\text{Newton}}{\text{Ampere} \times \text{meter}} = 1 \text{ Tesla}$$

It is called 1 Tesla.



Weblinks

Encourage students to visit below link for Magnetic field due to a current carrying conductor
https://www.youtube.com/watch?v=5fY74-v96N0&ab_channel=Learnnhvfun

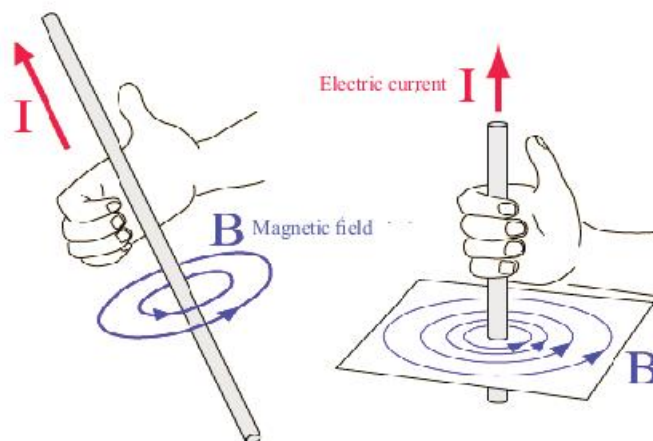

Fig: 16.7 Current carrying conductor produce magnetic field



SELF ASSESSMENT QUESTIONS:

- Q1:** Why the workdone on a charge is zero by magnetic force?
- Q2:** If two wire placed parallel, when current following in same direction, what will be happen?
- Q3:** What is the angle between \vec{E} and \vec{B} in a electromagnetic wave?

Define Magnetic field

The magnetic field is the region in which the influence of magnetism may be felt in the region of a magnet, and it is defined as follows: When we talk about magnetic fields in nature, we're talking about how the magnetic force is diffused throughout the space surrounding and inside magnetic objects in the physical world.

Sketch the lines of magnetic force.

In general, the magnetic field is the strongest near the poles, and the weakest at the centre.

Magnet field lines

Magnetic field lines are imaginary lines coming outward from the north pole and going inward in a south pole and inside a bar magnet magnetic field will be zero. The magnetic field is stronger at the end of pole because magnetic field lines are very closer at end of poles.

To understand magnetic field lets preform an activity, Take a bar magnet and hundreds of iron filings; place the bar magnet on a table and sprinkle the iron filings on it; the iron filings will self-organize into curving lines called magnetic field lines, as seen in the figure

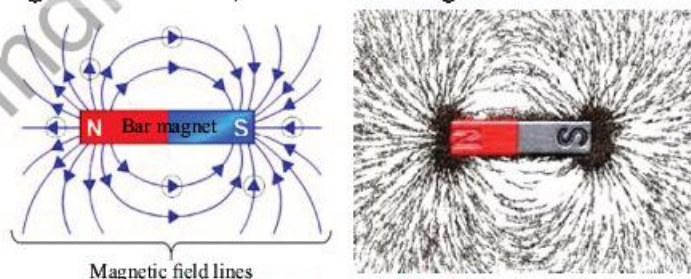
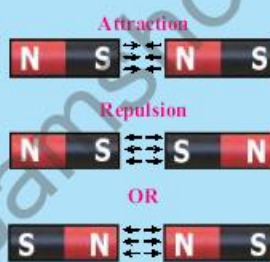

Fig: 16.8. Magnetic field lines

Do You Know!

Like poles repel one another, whereas unlike poles attract one another.



Do You Know!

Earth has magnetic field around it, because of flowing of liquid metal in the outer core cause to generates electric currents., it protected from the solar wind, a stream of energetic charged particles emanating from the Sun, by its magnetic field, which deflects most of the charged particles. The earth magnetic field is $50\mu\text{T}$.





Do You Know!

Beautiful coloured lightening happened in north and south pole because the shape of Earth's magnetic field creates two aurora above the North and South Magnetic Poles.



SELF ASSESSMENT QUESTIONS:

- Q1:** Are magnetic lines of force real?
Q2: What is the source of the magnetic field?
Q3: What are the magnetic lines of force?
Q4: What is the direction of magnetic field inside the bar magnet?
Q5: Can monopole of magnet exist?

16.2 Force on current carrying conductor in a magnetic field

When a conductor of length L carrying current, I and placed in a magnetic field B at an angle θ as shown in figure 16.9, it experiences a force:

$$F = I (l \times B)$$

$$F = BIL \sin \theta$$

$$B = \frac{F}{I \sin \theta}$$

We know that current in a conductor is due to the directional drift of free electrons along the conductor so when a conductor is placed in a uniform magnetic field B and if the current, I is passed, the conductor experiences a force as mentioned above.

When a conductor carries an electric current, a magnetic field is produced around it.

OR

It exhibits magnetic properties and generates a force when another magnet is brought into its magnetic field. In the same way.

The magnetic field has an equal and opposite effect on the conductor carrying the current. This is because two magnetic fields (from the current-carrying conductor and the nearby magnet) can attract or repel each other. The direction of the external magnetic field and the direction of the current in the conductor are responsible for this attractive and repulsive forces. The direction of the force acting on the conductor will be perpendicular to the direction of the magnetic field and the electric current if they are perpendicular to each other.

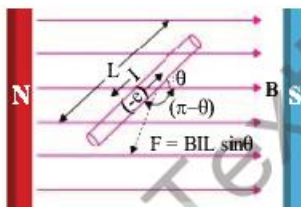

Fig: 16.9
Current carrying conductor in magnetic field



Worked Example 1

Calculate the force on the wire shown in Figure (a)

Solution

Step 1: Write down the known quantities and quantities to be found.

$$B = 1.50 \text{ T}$$

$$l = 5.00 \text{ cm}$$

$$I = 20 \text{ A}$$

$$\theta = 90^\circ$$

$$F = ?$$

Step 2: Write down the formula and rearrange if necessary.

$$F = IlB \sin \theta$$

Step 3: Put the values and calculate

$$F = IlB \sin \theta$$

$$F = I l B \sin \theta = (20 \text{ A})(0.0500 \text{ m})(1.50 \text{ T})(1)$$

$$\text{The units for tesla are } 1 \frac{\text{N}}{\text{Am}} = \text{T} \rightarrow \text{N} = \text{AmT}$$

$$F = 1.50 \text{ N}$$

Result: The force on a wire is $F = 1.50 \text{ N}$.

16.3 Turning effect on a current-carrying coil in a magnetic field

When a current passes through the coil, equal and opposite parallel forces act respectively on the sides of the coil beside the poles of the permanent magnet. This pair of forces produces a turning effect to rotate the coil until it is stopped by the control springs.

A current-carrying coil kept in a magnetic field experiences a torque, which is the cross-product of the magnetic moment and the field vector. Hence, the torque is maximum when the dipole moment is perpendicular to the field, and zero when it's parallel or antiparallel to the field.

When an electric current is passed through a coil, placed in a magnetic field with its plane parallel to the field, it experiences a torque. Thus, this rectangular coil tends to rotate in the magnetic field and it suffers torque. This torque is:

$$\tau = BIAN \cos \alpha$$

Consider a rectangular coil placed in the magnetic field of

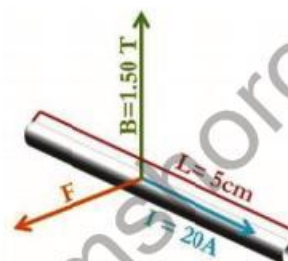

Fig: (a)

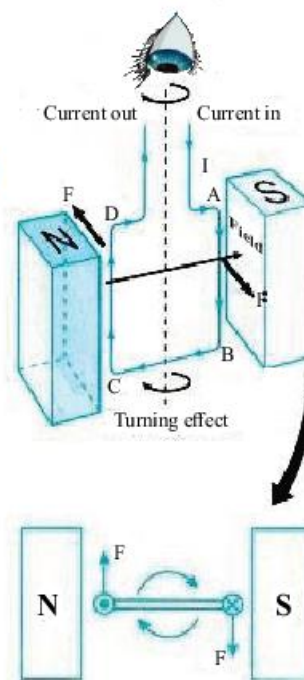

Fig: 16.10
Torque on coil current carrying conductor



Do You Know!

Invention of D.C motor

William Sturgeon invented the first D.C motor, that could provide enough power to drive machinery but it wasn't until 1886 that the first practical D.C motor that could run at constant speed under variable weight, was produced. Frank Julian Sprague was its inventor and it was this motor that provided the catalyst for the wider adoption of electric motors in industrial applications.

strength B and the plane of the coil is parallel to the field and is free to rotate about an axis.

When current I passed through the coil, a force is experienced on the perpendicularly placed conductor. The magnitude of the force is $F = BIL$. Hence a pair of two equal but opposite forces (couple) acts on the coil. That causes the coil to rotate.

So, Torque = $\tau = BIA$

If the plane of the coil makes an angle α with the field B then the perpendicular distance $\text{Cos } \alpha$ can be added:

$$\tau = BIA \text{Cos } \alpha$$

If the coil has N turns, then:

$$\tau = BIAN \text{Cos } \alpha$$

16.4 D.C motor

D.C Motor is an Electromechanical device that converts electrical energy into mechanical energy. D.C Motor is similar to D.C Generator in construction but the output device act as input and input as output.

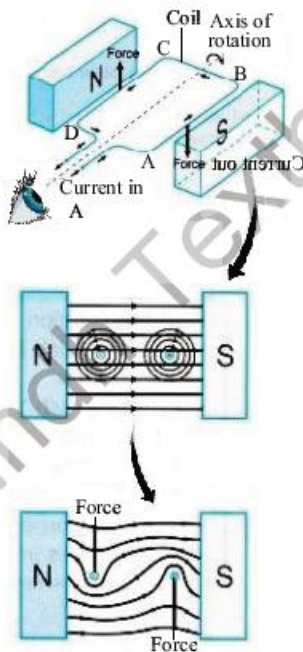

Fig: 16.12 Torque on D.C motor

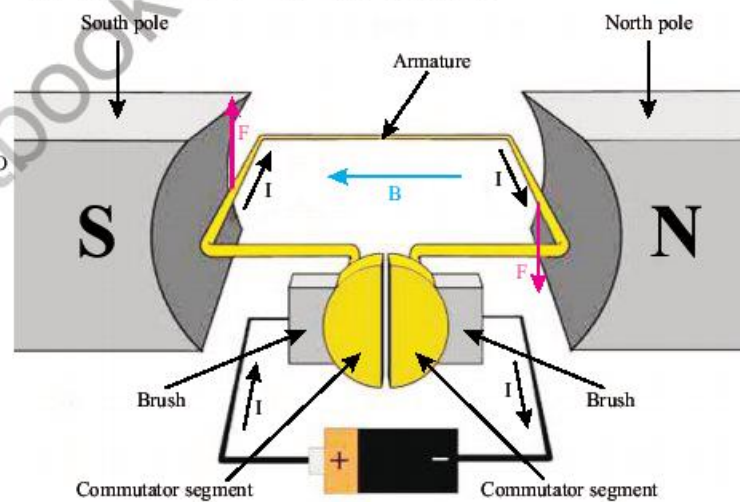

Fig: 16.11. Turning effect on D.C motor

Turning effect on D.C motor coil

A current-carrying coil in a magnetic field experiences a turning effect. In Figure 16.12, a rectangular coil ABCD carries a current in the magnetic field between two magnets.



- (a) The sides BC and DA carry currents with directions parallel to the magnetic field. No force is exerted on these two sides.
- (b) The side AB next to the South pole experiences a force. The direction of the force can be determined using Fleming's left-hand rule or the right-hand slap rule.
- (c) The side CD experiences a force that acts in the opposite direction.

The two forces acting in opposite directions on the two sides of the coil form a couple and produce a turning effect on the coil. The forces are produced when the magnetic field due to the current in the coil combines with the external magnetic field to produce two resultant catapult fields around the coil; Figure 16.13.

Two important applications of the turning effect of a current-carrying coil in a magnetic field are the direct current motor and the moving-coil galvanometer.

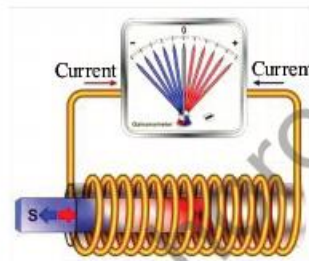

Fig: 16.13
Electromagnetic induction



Do You Know!

Concept of electromagnetic induction given by "**Joseph Henry**" in 1830, from USA



"**Michael Faraday**" from England also gave the concept of electromagnetic induction and in 1831.



SELF ASSESSMENT QUESTIONS:

Q1: How can the turning effect of a coil be increased?

Q2: How do DC motor coils rotate?

16.5 Electromagnetic induction

A voltage is created – or induced. For this reason, we call this electromagnetic induction. Electromagnetic or magnetic induction is the production of an electromotive force across an electrical conductor in a changing magnetic field. Michael Faraday is generally credited with the discovery of induction in 1831, and James Clerk Maxwell described mathematically it as Faraday's law of induction.

Changing magnetic field can induce e.m.f in a circuit.

Faraday demonstrates that magnetic fields can create currents as illustrated in figure 16.14. When the magnet shown below is moved "towards" the coil, the Galvanometer's pointer or needle will deflect away from its centre position in one direction only. When the magnet stops moving and is held stationary with respect to the



coil, the needle of the galvanometer returns to zero as there is no physical movement of the magnetic field.

Similarly, when the magnet is moved "away" from the coil, the galvanometer needle deflects in the opposite direction, indicating a change in polarity. By moving the magnet back and forth towards the coil, the needle of the galvanometer will deflect left or right, positive or negative, relative to the magnet's motion.

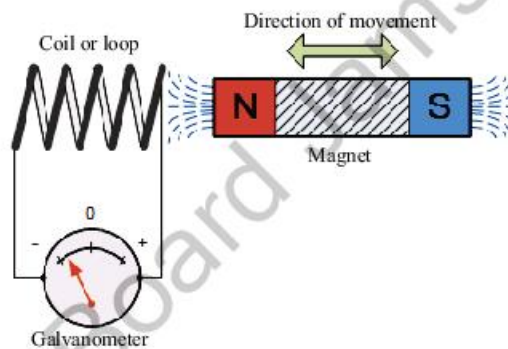

Fig: 16.14 changing magnetic produced induced e.m.f
Electromagnetic Induction by a Moving Magnet

if you keep the magnet stationary and move only the coil toward or away from the magnet, the needle on the galvanometer will also move in either direction. A voltage is induced in a coil when the coil is moved through a magnetic field, and the magnitude of this voltage is proportional to the speed at which the coil is moved.

For Faraday's law to be valid, either the coil or the magnetic field (or both) must be in "relative motion" with one another for the induced emf or voltage to be increased with increasing field speed.

Faraday's Law of Induction

From the above description we can say that a relationship exists between an electrical voltage and a changing magnetic field to which Michael Faraday's famous law of electromagnetic induction states:

A voltage is induced in a circuit whenever relative motion exists between a conductor and a magnetic field and that the magnitude of this voltage is proportional to the rate of change of the flux".

// eLinks

Encourage students to visit below link for Electromagnetic induction and Faraday's law

https://www.youtube.com/watch?v=3HYORmBip-w&ab_channel=KhanEdu

// eLinks

Encourage students to visit below link for Faraday's law of induction

https://www.youtube.com/watch?v=vc2tzn2MG0&ab_channel=KhanAcadem



Factors affecting the magnitude of an induced e.m.f.

The factors involved in the induced emf of a coil are:

- The induced e.m.f. is directly proportional to N , the total number of turns in the coil.
- The induced e.m.f. is directly proportional to A , the area of cross-section of the coil.
- The induced e.m.f. is directly proportional to B , the strength of the magnetic field in which the coil is rotating.
- The induced e.m.f. is directly proportional to ' ω ', the angular velocity of the coil.
- The induced e.m.f. also varies with time and depends on instant ' t '.
- The induced e.m.f. is maximum when the plane of the coil is parallel to magnetic field B and e.m.f. is zero when the plane of the coil is perpendicular to magnetic field B .

Lenz's law of electromagnetic induction

According to Faraday's law of electromagnetic induction, a changing magnetic field induces a current in a conductor. Lenz's law of electromagnetic induction states that the magnetic field produced by the induced current opposes the original magnetic field that produced the current. The right hand rule, developed by Fleming, specifies the direction of this current's flow.

Keep in mind that the magnetic field produced by an induced current generates an additional magnetic field, which is Always opposing the magnetic field that formed it. Below illustration showing that, if magnetic field " B " is increasing, the induced magnetic field will oppose it in figure 16.15(a).

As illustrated in 16.15(b), the induced magnetic field will once again oppose the magnetic field " B " when " B " is decreasing. This time, "in opposition" suggests it's acting to increase the field by opposing the decreasing rate of change.

Lenz's law derives from Faraday's law of induction. According to Faraday's law, a conductor will experience an electric current when subjected to a changing magnetic

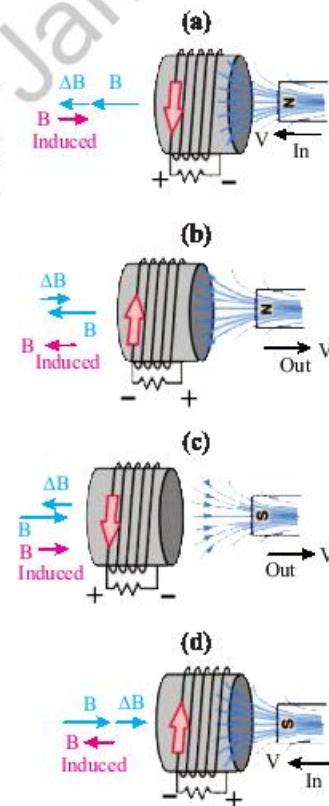

Fig: 16.15 Magnetic field induced by magnetic current



Weblinks

Encourage students to visit below link for Lenz's Law and Conservation of Energy

https://www.youtube.com/watch?v=wsuBld3Bo00&ab_channel=YenLingLam



Do You Know!

Lenz's law is about the conservation of energy applied to the electromagnetic induction, whereas Faraday's law is about the electromagnetic force produced.

field.

When a magnetic field changes, an induced current will flow in the opposite direction, as described by Lenz's law. That's why the minus sign ('-') appears in the formula for Faraday's law to emphasize this point.

It is possible to alter the magnetic field intensity by moving a magnet closer to or farther from the coil, or by moving the coil itself into or out of the magnetic field.

In other words, we can say that the magnitude of the EMF induced in the circuit is proportional to the rate of change of flux.

$$\mathcal{E} \propto -\frac{d\Phi_B}{dt}$$

$$\mathcal{E} = -N \frac{d\Phi_B}{dt}$$

Where:

- \mathcal{E} = Induced emf
- $d\Phi_B$ = change in magnetic flux
- N = No of turns in coil

Lenz's Law and Conservation of Energy

To obey the law of energy conservation, the direction of the current induced by Lenz's law must create a magnetic field that is opposite to the magnetic field that created it. In fact, Lenz's law is a result of the law of conservation of energy.

If the magnetic field created by the induced current is in the same direction as the field that produced it, then the two magnetic fields would combine to make a larger magnetic field.

By combining their magnetic fields, they may create a field that is twice as strong as the original one, inducing a current twice as large in the conductor.

As a result, a new magnetic field would be produced, which in turn would induce a new current. And so on.

Because of this, it is easy to understand that the conservation of energy would be violated if Lenz's law did not state that the induced current must produce a magnetic field that opposes the field that originated it.

The third law of motion of Newton applies to Lenz's law



as well (i.e to every action there is always an equal and opposite reaction).

If the induced current makes a magnetic field in the same direction as the magnetic field that made it, then it is the only thing that can stop the change in the magnetic field in the area. This is consistent with Newton's third law of motion.

16.6 A.C generator

An AC generator is an electric generator that converts mechanical energy into electrical energy in the form of alternative emf or alternating current. An AC generator works on the principle of "Electromagnetic Induction".

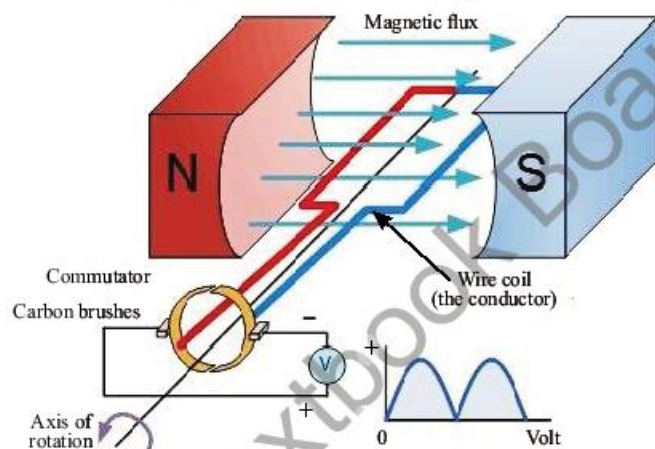

Fig: 16.16 A.C generator

16.7 Mutual induction

When the electric current in the Primary Coil changes, the magnetic field changes as well, linking the Secondary Coil to the Primary Coil. In the secondary coil, this shifting flux causes an e.m.f. Mutual Induction describes this process. The secondary coil's e.m.f. is proportional to the primary coil's rate of change of current. Thus:

$$\mathcal{E}_s \propto \frac{\Delta I_p}{\Delta t}$$

$$\mathcal{E}_s = -M \frac{\Delta I_p}{\Delta t}$$

Do You Know!
The S.I unit of mutual inductance is "Henry" while is equal to $\frac{\text{Volt - Sec}}{\text{Amp}}$

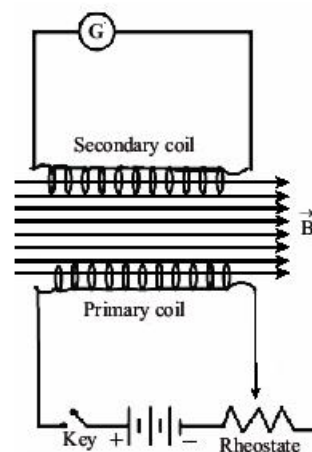

Fig: 16.17 Mutual induction



Do You Know!

- Stabilizer is the example of step up transformer
- Mobile charger is the example of step down transformer
- Working principle of transformer based upon mutual induction

Where M is a constant, called Mutual Inductance of the two coils.

Hence:

$$M_{21} = \frac{\epsilon_s}{\Delta I_p / \Delta t}$$

SELF ASSESSMENT QUESTIONS:

- Q1:** Define mutual induction.
Q2: Enlist the factors affecting the induced e.m.f.
Q3: How A.C generator works?

16.8 Transformer

Transformer is a static machine used for transforming power from one circuit to another without changing the frequency. Transformers operate based on the principle of **mutual induction**. It operates on an AC supply.

It consists of two coil which are magnetically linked to each other but electrically isolated from one another although wrapped around the same iron core, make up a transformer. The primary coil is the first of two coils in the system which is connected to A.C input power. The secondary coil is the other coil which delivers the power to the output circuit. N_p and N_s stand for the number of turns on the primary and secondary coils, respectively.

When current passing through the primary coil generates magnetic field, which is transmitted to the secondary coil through the core. The change in the field causes an alternating e.m.f. to be generated in the secondary coil.

The secondary voltage V_s is proportional to the primary voltage V_p . The ratio of the number of turns on the secondary coil to the number of turns on the main coil also affects the secondary voltage, as illustrated by the following expression:

$$\frac{V_s}{V_p} = \frac{N_s}{N_p}$$

The transformer is referred to as a step-up transformer if the secondary voltage exceeds the primary voltage; Fig.16.18 (a).

A step-down transformer is one in which the secondary voltage is lower than the primary voltage; Fig.16.18 (b).

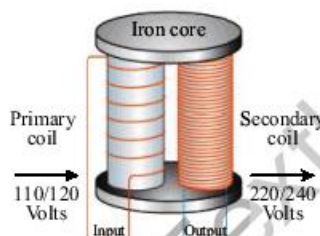

Fig: 16.18 (a)
Step up transformer

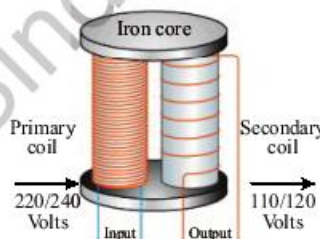

Fig: 16.18 (b)
Step down transformer



The electric power transferred to the secondary circuit in an ideal transformer is the same as the primary circuit's power.

An ideal transformer dissipates no power, and we may write the following mathematical expression for such a transformer

$$P_P = P_S$$

$$V_P I_P = V_S I_S$$

Role of Transformer in Power Transmission

Generation of electrical power in low voltage level is very much cost effective. Theoretically, this low voltage level power can be transmitted to the receiving end. This low voltage power if transmitted results in greater line current which indeed causes more line losses.

But if the voltage level of a power is increased, the current of the power is reduced which causes reduction in ohmic or $P = I^2R$ losses in the system, reduction in cross-sectional area of the conductor i.e. reduction in capital cost of the system and it also improves the voltage regulation of the system. Because of these, low level power must be stepped up for efficient electrical power transmission.

This is done by step up transformer at the sending side of the power system network. As this high voltage power may not be distributed to the consumers directly, this must be stepped down to the desired level at the receiving end with the help of step down transformer. Electrical power transformer thus plays a vital role in power transmission.

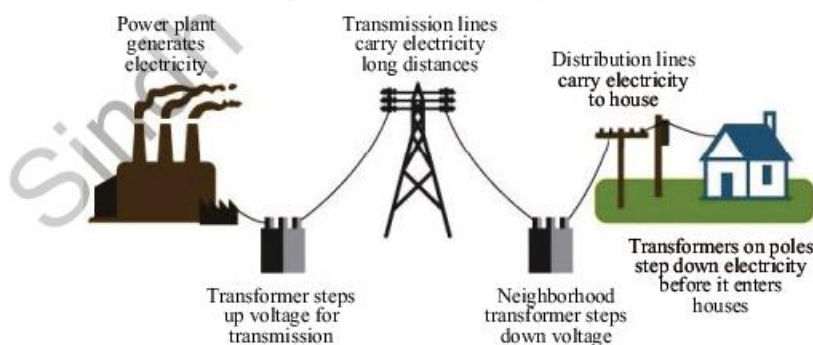

Fig: 16.19
Power transmission from power house to residential area



Weblinks

Encourage students to visit below link for
How does a transformer works

https://www.youtube.com/watch?v=UchitHGF4n8&ab_channel=TheEngineeringMindset



Weblinks

Encourage students to visit below link for
Role of transformer in power transmission

https://www.youtube.com/watch?v=agujzHdvtjc&ab_channel=PhysicsVideosbyEugeneKhutoryansky



Fig: 16.20
Transformer in
stabilizer



Fig: 16.21
Transformer battery
charger



Fig: 16.22
Transformer in high
voltage circuit breaker

Daily life applications of transformers

Transformers are widely used because of their ability to regulate the strength of alternating current, which improves efficiency and, in turn, reduces monthly electricity costs. By the use of transformers, we have observed and seen its importance in our everyday life and without it, electricity would have caused great destruction in our homes and industries.

There are several ways a transformer can be used in homes.

In stabilizer:

A stabilizer is made up of transformers that help to give out a voltage or manage voltage in such a way that it is ok with the voltage circuits. It helps to step down and step up the level of current in a building.

In Battery Charger:

Batteries can also be charged with the help of transformers. The voltage needs to be controlled properly so that it doesn't damage the parts inside the battery. This can only be done with the help of a step down transformer.

In circuit breaker:

Circuit breakers with integrated transformers can prevent damage from high voltage current by allowing users to manually switch on and off power.

In air conditioner (AC):

This is another modern use of a transformer in our homes. Because of its high inductance and low resistance levels, it aids in the proper functioning of the AC. Without this, there would be no long-lasting AC (Air condition) in our home.

SELF ASSESSMENT QUESTIONS:

- Q1: What is transformer and how its works?
Q2: What is the difference between step up and step down transformer?
Q3: For what purpose step up and step down transformers are used in power transmission?



SUMMARY

- Electromagnetic force acts between charged particles.
- The direction of magnetic field around a current carrying wire can be determined by using the Flemings right hand rule for conductors.
- The region in which the influence of magnetism may be felt is known as magnetic field.
- Magnetic field is strongest near the poles and weakest in the centre.
- A current carrying wire has a magnetic field around it. When this field interacts with external magnetic field there is a force on it, which is given by $F = I L \times B$.
- DC motor is a device which converts the electrical energy into mechanical energy.
- Faraday noticed that when he moved a permanent magnet in and out of a coil or a single loop of wire it induced an Electro Motive Force or emf, in other words a Voltage, and therefore a current was produced.
- Torque on a current carrying coil in magnetic field is $\tau = NIAB \sin \theta$.
- The change of magnetic flux due to a variation in the current flowing in another circuit.
- Dynamically induced e.m.f: When the conductor is moved in a stationary magnetic field in such a way that the flux linking it changes in magnitude.
- Statically induced e.m.f: When the conductor is stationary and the magnetic field is moving or changing.
- Eddy currents: The currents induced in conductor moving in a magnetic field or metals that are exposed to a changing magnetic field.
- Generator is an electrical machine which converts mechanical energy into electrical energy.
- Electrical transformer plays vital role in power transformation. In addition, transformers can be used to scale up or down an alternating voltage's intensity. It works on the idea of mutual induction.



CONCEPT MAP

Electromagnetism

The branch of Physics which deals with magnetic effects of electric current

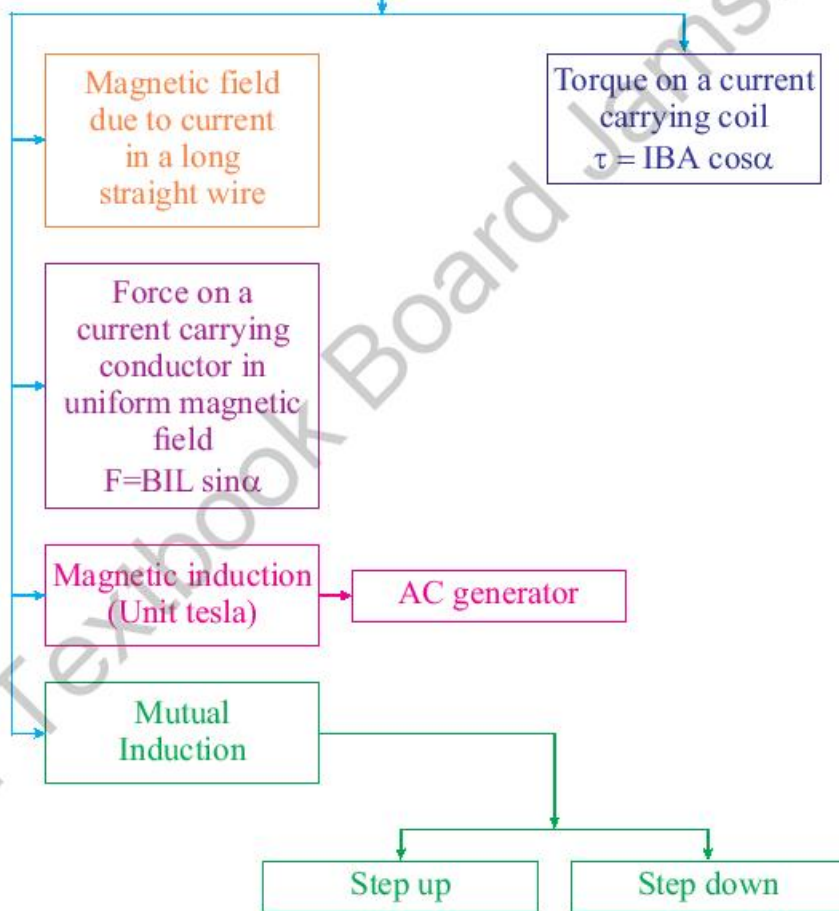



Section (A) Multiple Choice Questions (MCQs)

- Which statement is true about the magnetic poles?
 - unlike poles repel
 - like poles attract
 - magnetic poles do not effect each other
 - a single magnetic pole does not exist
- What is the direction of the magnetic field lines inside a bar magnet?
 - from north pole to south pole
 - from south pole to north pole
 - from side to side
 - there are no magnetic field lines
- The presence of a magnetic field can be detected by a
 - small mass
 - stationary positive charge
 - stationary negative charge
 - magnetic compass
- If the current in a wire which is placed perpendicular to a magnetic field increases, the force on the wire
 - Increases
 - decreases
 - remains the same
 - will be zero
- A D.C motor converts
 - mechanical energy into electrical energy
 - mechanical energy into chemical energy
 - electrical energy into mechanical energy
 - electrical energy into chemical energy
- Which part of a D.C motor reverses the direction of current through the coil every half-cycle?
 - the armature
 - the commutator
 - the brushes
 - the slip rings
- The direction of induced e.m.f. in a circuit is in accordance with conservation of
 - Mass
 - charge
 - momentum
 - energy
- The step-up transformer
 - increases the input current
 - increases the input voltage
 - has more turns in the primary
 - has less turns in the secondary coil
- The turn ratios of a transformer is 10. It means
 - $I_S = 10 I_P$
 - $N_P = 10 N_S$
 - $N_S = 10 N_P$
 - $V_S = 10 V_P$



Section (B) Structured Questions

1. A wire in a magnetic field generates voltage. To generate maximum voltage, move the wire in what direction relative to the field?
2. Can a transformer operate on direct current?
3. Demonstrate through an experiment how an electric current in a conductor generates a magnetic field in its vicinity.
4. Explain how a force works on a current-carrying conductor that is perpendicular to the magnetic field.
5. State that, a current carrying coil in a magnetic field will experience a torque.
6. Describe an experiment that demonstrates the induction of e.m.f. in a circuit by a varying magnetic field.
7. Give some examples of what could increase or decrease the strength of an induced e.m.f.
8. Explain that the direction of an induced e.m.f. opposes the change causing it and relate this phenomenon to conservation of energy.
9. Explain how an A.C. generator works in its most simple form.
10. Explain the units of mutual induction and provide an example.
11. Recognize that a transformer is based on the concept of mutual induction between two coils.
12. Explain what role transformers play in alternating current (AC) circuits.
13. Determine the function of transformers in the process of moving electrical current from the power plant to your home.
14. Compile a list of the numerous applications of transformers (step-up and step-down) that can be found in your home.

Section (C) Numericals

1. A wire carrying 4A current and has length of 15 cm between the poles of a magnet is kept at an angle of 30° to the uniform field of 0.8 T. Find the force acting on the wire?
(0.24N)
2. A square loop of wire of side 2.0 cm carries 2.0 A of current. A uniform magnetic field of magnitude 0.7 T makes an angle of 30° with the plane of the loop. What is the magnitude of torque on the loop?
(4.8×10^{-4} Nm)
3. A transformer is needed to convert a mains 220 V supply into a 12 V supply. If there are 2200 turns on the primary coil, then find the number of turns on the secondary coil.
(120)
4. A coil surrounding a long solenoid, the current in the solenoid is changing at a rate of 150A/s and the mutual induction of the two coils is 5.5×10^{-5} H. Determine the emf induced in the surrounding coil?
(-8.25×10^{-3} V).

Unit - 17

Introductory Electronics

Students Learning Outcomes (SLOs)

After learning this unit students should be able to

- ▶ Identify by quoting examples that the modern world is the world of digital electronics.
- ▶ Identify that the computers are the forefront of electronic technology.
- ▶ Realize that electronics is shifting from low-tech electrical appliances to high-tech electronic appliances.
- ▶ Differentiate between analogue and digital electronics.
- ▶ Explain the process of thermionic emission emitted from a filament.
- ▶ Describe the simple construction and use of an electron gun as a source of electron beam.
- ▶ Describe the effect of electric field on an electron beam.
- ▶ Describe the effect of magnetic field on an electron beam.
- ▶ Describe the basic principle of CRO and make a list of its uses.
- ▶ State the basic operations of digital electronics.
- ▶ Identify and draw the symbols for the logic gates (NOT, OR, AND, NOR and NAND).
- ▶ State the action of logic gates in truth table form.
- ▶ Describe the simple uses of logic gates.

Electronics controls electron motion using various electronic devices. Electronic devices manage electron flow for information processing and system control. Both the world and technology are changing very quickly.

Every day, a new device develops to make our lives easier. Electronic devices are so important that we can't picture a day without them.

Everything from a telephone to a washing machine. If we look around us, and every corner has an electric device. The reason we are getting so used to it is simple, it is easier and it takes no time to get the work done.



Laptop



Camera



Loud speakers



Projector

Fig: 17.1.
Some electronic devices

Please recall that, the following questions may arise in your mind time to time that:

- What is the difference between analogue and digital electronics?
- Why digital electronics based devices are more rapidly growing than analogue based devices?
- Why computer process the data at extremely high speed?
- Have you ever think why the electrons are emitted from a filament?
- How electron beams are formed?
- Why electron beams are deflected by both electric and magnetic fields?
- Why electronic devices are better than electrical devices?

After studying this unit you will be able to find the answers of such questions and develop the clear concepts.

17.1 INTRODUCTION TO ELECTRONICS

In 1897 electron was identified. Vacuum tube was invented in the same period of time. Vacuum tube can amplify and rectify small electrical signals. The invention of vacuum tube opens up a new field of technology called "ELECTRONICS". Electronics comprises the physics, engineering and technology. Electronics also has applications that deal with the emission, flow and control of electrons in vacuum and matter using different devices.

The progress in the field of science and technology depends upon the ability to measure, calculate and finally estimate the unknown. There are three ways in which this could be done.

1. Mechanical (Measurement of gas pressure by pressure gauge.)
2. Electrical (Measurement of current with electrical ammeter.)
3. Electronics (Measurement of potential difference by cathode-ray oscilloscope.)

Among above three ways the electronics is far better. Since, in electronics we get higher sensitivity, faster



response and greater flexibility in indicating, recording and controlling the measured quantity.

Electronics may have two fields:

- (1) Analogue
- (2) Digital

Modern World Is The World Of Digital Electronics:

Digital electronic technology is a revolution in the field of information. Data of any sort can be instantly and accurately retrieved from any part of the world. Internet is just the start of this global sharing of information.

The conversion of signals from analogue to digital has been the key to this digital revolution, their processing and transmission in digital form and their conversion back into analogue form.

It is now possible to perform many tasks digitally which were used to be carried out using analogue electronics. Digital information has several advantages over analogue information. Some of these advantages are:

- (i) Easy storage.
- (ii) Easy transmission.
- (iii) Large amplification.
- (iv) Less noisy signal (clear signal).
- (v) Negligible power or line losses.

Digital electronics devices have many advantages over analogue electronic devices. Some of these advantages are:

- (i) They have greater speed.
- (ii) They are very sensitive.
- (iii) Their displays are easily readable.
- (iv) They are very accurate.
- (v) They have better resolution.
- (vi) They can monitor remote signals.
- (vii) Their sizes are small.

For example: A digital voltmeter (DVM) has following advantages over electrical voltmeter.

- (i) Higher accuracy.



Fig: 17.2.
Analogue devices



Fig: 17.3.
Digital devices



Do You Know!



Digital Cameras are fast, reliable and easy to use. They provide quality pictures with better resolutions. These pictures can be edited as per our requirements.



Do You Know!

Now electronic sensors can digitally measure the continuously varying quantities such as temperature, pressure or positions and some other quantities.



Do You Know!



A 1960 Newmark analogue computer, made up of five units. This computer was used to solve differential equations and is currently housed at the Cambridge Museum of Technology.

- (ii) Higher resolution.
- (iii) Greater speed.
- (iv) No parallax errors.
- (v) Reduced human error.
- (vi) Compatibility with other digital equipments.

Above reasons made the modern world, the world of digital electronics.

The digital electronics, based devices are used all over the world in every field of life. E.g. mobile phones, LED, LCD, laptops, watches, calculators, cathode-ray oscilloscopes, digital balances, sensors, alarms, digital versatile discs (DVD's), amplifiers, in telecommunication, MP3 player.

17.2 "COMPUTERS" THE FOREFRONT OF ELECTRONIC TECHNOLOGY:

Electronic technology is improving day-by-day. Electronic devices are proving more efficient, accurate, fast, less costly, flexible, portable and smaller in size with time. There are advancements in electronic technology in every field but computers can be regarded as the fore front (i.e. the most prominent part of electronic technology). Because computers are the most simple and accurate electronic machines that can receive data from many input devices, process this data and produce the results in desired format. They can also store data. The powerful flexible computers available now a day have revolutionized modern life in many different ways. Computers are the basic need of the everyday life. Computers are used almost everywhere for various purposes.

For example: Computers are used in industries, offices, research organizations, educational institutes, shopping malls, business, home, hospitals etc, for designing, storing data, solving research problems, study, graphics, billing, keeping trade records, communication, playing games and much more.



In 1980's a mainframe computer occupies a room is now may be a desktop, a laptop or a tablet computer. So, with the passage of time the speed of computer increased and its size is reduced. Computer with internet is now becomes the most powerful tool of communication which transfers required data within seconds from one part of the world to other. Thus computer is the forefront of electronic technology which is making the world into a global village. With the growing advancement in electronic technology, one day it might be possible to dispense keyboard of a computer altogether and instead just talk to computer.

17.3 ADVANCEMENT FROM LOW-TECH ELECTRICAL TO HIGH-TECH ELECTRIC APPLIANCES:

High-tech is abbreviated from High technology. A high technology is the most advanced technology available. The Low-tech is abbreviated from Low technology. A low technology is opposite of high technology. The low technology refers to simple, often traditional or not advanced technology.

The use of digital electronics (technology) enters into new era. This shifts the world from low-tech electrical appliances to high-tech electronic appliances. This happens due to the following reasons that the digital appliances are more efficient, accurate. They are flexible, compact and easy to use. These appliances have negligible power losses. They consume less energy.

There are many examples in our daily life like:

- The field of data storage is improved a lot. The images recorded in digital camera can be transferred to computer where they can be edited easily.
- The record of a person such as ID card, passport, driving license, insurance card, health card and biometric data (voice scan or eye-retina scan) can all be stored on a single tiny chip.



Fig: 17.4.
A low-tech (analogue)
computer



Fig: 17.5.
A high-tech (digital)
computer

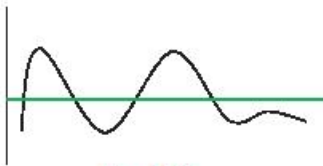

Fig: 17.6.
Analog signal

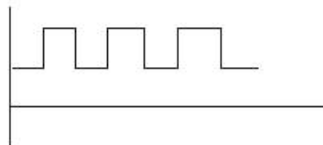

Fig: 17.7.
Digital signal



Fig: 17.8.
Different analogue and
digital devices

The way of communication has changed drastically. For example, the telephone signals which were transmitted electrically through copper wires are now transmitted digitally (as light) through optical fibers.

Digital television gives excellent picture and sound.

Equipments used in film industry for recording were camera, sound recorder, audio visual recording tape etc. These recording equipments are now replaced by digital cameras. Digital camera can perform all these operations with better resolution and accuracy.

17.4 DIFFERENCE BETWEEN ANALOGUE AND DIGITAL ELECTRONICS:

Electronics can be divided into two categories:

1. Analogue electronics.
2. Digital electronics.

First we understand the differences between analogue and digital electronics by their signals and examples from daily life, then we will differentiate them by their properties:

Analogue electronics deals with circuits which have continuously varying signals. For example; radio, television, oscillator etc.

An analogue signal is shown below:

The term “digital” derived from a Latin word “Digitus” means for fingers. This is because fingers are usually used for discrete counting.

Thus digital electronics deals with circuits which have discrete signals. For example computers, calculators, MP3 players etc.

A digital signal is shown below:

The differences between analogue and digital electronics can be summarized in the table below:



S. No.	Analogue Electronics	Digital Electronics
1.	Measures continuously varying quantities.	Measures discrete as well as continuously varying quantities.
2.	Analogue signals are in the form of a wave.	Digital signals are in the form of 0's and 1's. These two levels can be joined to form a square wave.
3.	Data can not be stored closely (compactly).	Data can be stored more closely (compactly) like in CD's.
4.	Analogue signals are very much affected by noise (the unwanted voltage fluctuations).	Digital signals are almost not affected by noise (the unwanted voltage fluctuations).
5.	Analogue data can be transmitted less efficiently and reliably.	Digital data can be transmitted more efficiently and reliably.
6.	Amplified analogue signal does have noise.	Amplified digital signal almost do not have noise.
7.	Analogue devices have high precession.	Digital devices have very high precession.
8.	Examples of analogue devices includes ordinary air thermometer, the barometer, the speedometer, vehicles, the mechanical watches etc.	Examples of digital devices includes computers, calculators, watches, MP3 players, DVD's, laptops, sensors, biometric machines, chip in ID cards etc.



Weblinks

Encourage students to visit below link for Digital vs Analog Why does it matter?

https://www.youtube.com/watch?v=ZWdT-6Ld71Q&ab_channel=BasicsExplained%2CH3Vtux



Weblinks

Encourage students to visit below link for Difference between Analog and Digital Signals

https://www.youtube.com/watch?v=WxJKXGugfh8&ab_channel=AddOhms



Do You Know!
Thermionic emission is like evaporation of molecules from a liquid surface.

Both analogue and digital electronics are used in many devices. Compact disc (CD) player is an example of it. The basic principle of a CD player is shown in the following simplified block diagram:

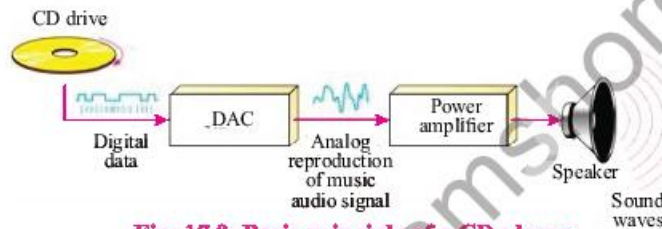

Fig: 17.9. Basic principle of a CD player

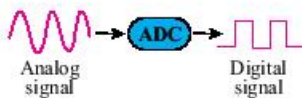

Fig: 17.10. Diagram of Analog to digital converter

Music stored on a compact disc in digital form. An optical system picks up this data and transfers it to the digital-to-analogue converter (DAC). The DAC changes this digital data into an analogue signal (The original music). This analogue signal is amplified by a linear amplifier and sent to speaker for us to listen. The reverse process to the above process was used when the music was originally recorded on the CD, using an analogue to digital converter (ADC). A diagram of an analogue to digital convertor (ADC) is shown in figure 17.10.

Self Assessment Questions:

- Q1: Write the names of any three analogue devices.
- Q2: Define the term “High-tech”?
- Q3: Write the names of any three digital devices.



Fig: 17.11. An ordinary bulb

17.5 THERMIONIC EMISSION

As we know that the metals are good conductors of electricity because they have free electrons. These electrons can easily move through the metal. If energy is supplied to these electrons they may leave the surface of metal.

The ordinary bulbs have tungsten filament. If, this tungsten filament is heated to a temperature of about two thousand degree centigrade (2000°C). Then, some of the electrons in the tungsten gain enough energy to escape from its surface. This effect is called “thermionic emission”. Thus:

Thermionic emission is the emission of electrons from a hot metal surface.



Demonstration of thermionic emission:

The thermionic emission effect is demonstrated below by an experiment. The figure 17.10. shows this experiment.

The vacuum tube shown in above figure is called a thermionic diode. This vacuum tube consists of two electrodes called the anode and the cathode.

The anode is positively charged so attracts negative charges (electrons).

The cathode is negatively charged so repels negative charges (electrons).

The cathode shown is made up of tungsten filament. Normally the gap between cathode and anode cannot be crossed by the electrons when the filament is switched OFF. As the filament is switched ON, the electrons escape from the hot tungsten surface. These electrons are attracted across to the anode. Hence thermionic emission occurs.

Note that if air is in the tube instead of having vacuum in it, thermionic emission still occurs.

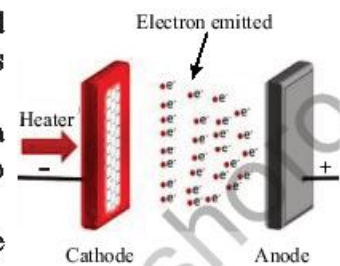

Fig: 17.12.
Model for thermionic emission

Self Assessment Questions:

- Q1: What is meant by thermionic emission?
- Q2: What particles are released by thermionic emission?
- Q3: Why cathode must be heated?

17.6 ELECTRON GUN AND CATHODE RAYS

The beam of fast moving electrons is called cathode rays. The filament of a bulb does not produce continuous flow of electrons. Since electrons are much smaller than the gas particles in the bulb. Therefore when electrons collide with gas particles they lose energy. As a result electrons do not travel very far continuously.

An electron gun made the electrons to travel in straight lines like a beam called "Cathode rays". These invisible rays were coming to found from the cathode. This leads to discovery of electron. These rays have following characteristics:

- They transfer negative charge (electrons).
- They transfer energy.
- They transfer mass.
- They transfer momentum.



Do You Know!

An electron microscope gives a three dimensional image of a very minute object by using narrow beam of electrons rather than light.

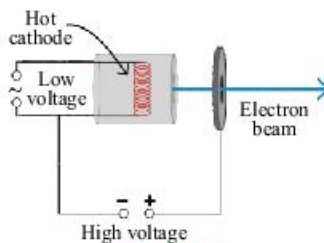

Fig: 17.13.
An electron gun



Do You Know!

Modern color TVs have three electron guns. Each gun produces separate beam for each of the three primary colors produced on the screen.

Their charge to mass ratio (e/m) is much larger than Hydrogen ion.

Their properties are independent of the choice of gas in the tube and also the metal used as cathode.

An electron gun as a source of electron beam:

The production of an electron beam by electron gun is shown in figure 17.13.

The above figure shows that an electron gun is used to produce a continuous flow of electrons. The electrons are emitted from the hot filament. The cathode is a metal plate warmed by the filament. The cathode is held at a negative potential compared with the anode. The anode is held at high positive potential. The difference of potential between cathode and anode is about thousands of volts. The electrons emitted from the hot filament are then accelerated by this large potential difference between cathode and anode. This produces fast moving electrons. As the electrons are negatively charged therefore they are repelled by cathode and attracted towards anode. So the electrons are not slowed down by colliding with air molecules. Hence a beam of fast moving electrons is produced. The electron gun is placed inside a sealed glass tube called vacuum tube because most of the air is removed from the tube. The fast moving e beams produced by electron gun are used in TV monitors, cathode ray oscilloscopes, electron microscopes and in some other devices.

Self Assessment Questions:

- Q1: Who made the electrons to travel in straight lines like a beam?
- Q2: Define cathode rays.
- Q3: Which one is held at high positive potential the cathode or the anode?

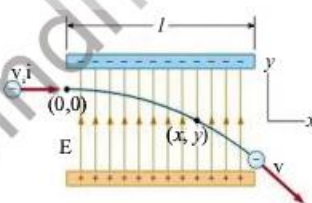

Fig: 17.14.
Deflection of electron passing through uniform electric field

17.7 DEFLECTION OF ELECTRON BY ELECTRIC FIELD

Electrons can be deflected by electric fields. The diagram given 17.14. shows the deflection of an electron passing through a uniform electric field at 90° to the direction of motion of electron.



This field is generated by parallel charged plates. The two plates are oppositely charged. Force acting on electron is constant and towards the positive plate as a result electron follows a curved path towards the positive plate.

Effect of electric field on an electron beam:

The beam of electron produced by the electron gun can be directed to a specific target. This could be done efficiently by:

- (i) Keeping the gun itself remains fixed.
- (ii) The beam of electrons to be deflected after it has been produced.

This could be done by deflecting the beam of electrons by an electric field. This field is provided by two oppositely charged metal plates. The deflection pattern of an electron beam is same to that of a single electron as discussed earlier. The effects of deflection of electron beam by an electric field are:

- (i) The beam bends and changes direction.
- (ii) The beam follows a parabolic (curved) path in the electric field.
- (iii) The beam of electron changes direction millions of times each second.
- (iv) The energy and speed of electron beam increases.
- (v) The beam continues to move in a straight line after passing through the electric field.

The deflection of electron beam by electric field is shown in figure 17.15.

Self Assessment Questions:

- Q1: How many times the beam of electron changes direction when it passes through an electric field?
- Q2: What happens to the energy and speed of an electron beam when it passes through an electric field?
- Q3: Describe the path of an electron in an electric field?

Do You Know!

The motion of an electron in an electric field is like the motion of a projectile in a gravitational field.

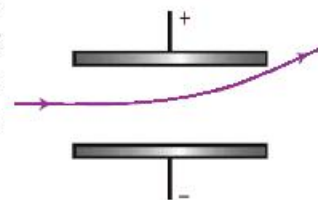

Fig: 17.15.
Deflection of electron beam

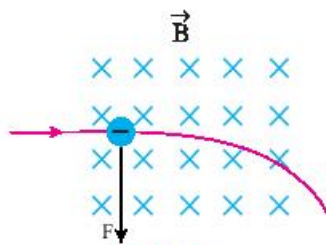

Fig: 17.16.
Deflection of electron passing through uniform magnetic field

17.8 DEFLECTION OF ELECTRON BY MAGNETIC FIELD

Electrons can be deflected by magnetic fields. The diagram given 17.16. shows the deflection of an electron passing through a uniform magnetic field acting at 90° to the direction of motion of electron.

This field is generated by passing a current through a pair of plates (coils). In the above figure the field is shown by “x” sign. This means that the field lines are perpendicular to the page and are directed into the page. This produces a force that acts at right angles to the direction of motion of electron. If the field direction is reversed, the force direction also reversed. The direction of the force can be found by Fleming’s left hand rule (Note that conventional current direction is opposite to that of electron flow). The electron changes direction and bends. Because the force acts at right angles to the direction of motion of electron, the electron will move in a circular path.

Effect of magnetic field on an electron beam:

The path of a beam of electrons which enters in a magnetic field acting perpendicular to the direction of motion is shown in figure 17.17.

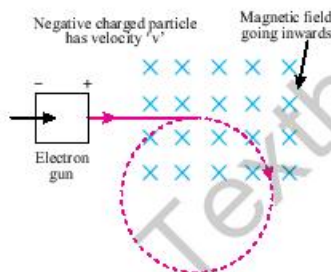

Fig: 17.17.
Effect of magnetic field

The effects of deflection of electron beam by a magnetic field are:

- (i) The beam bends and changes direction.
- (ii) The beam follows a circular path in the magnetic field.
- (iii) The energy of electron beam does not change in the magnetic field.
- (iv) The speed of electron beam does not change in a magnetic field.

Self Assessment Questions:

- Q1: Describe the path of an electron in a magnetic field?
- Q2: Which rule is used to find the direction of the force in a magnetic field?
- Q3: What happens to the speed of an electron beam as it passes through a magnetic field?



17.9 CATHODE-RAY OSCILLOSCOPE (CRO)

A Cathode-ray oscilloscope (CRO) is generally referred to as oscilloscope or scope. It can display and also measure many electrical quantities like ac/dc voltages, frequency etc. It is called a cathode ray oscilloscope because it traces a required wave-form with a beam of electrons called cathode rays. A cathode-ray oscilloscope (CRO) is used to observe the voltage waveforms of a transformer. A cathode-ray oscilloscope is used to display traces showing how a voltage varies with time. For example, the varying voltage produced by a microphone when it detects sound waves.

Basic principle of Cathode-ray oscilloscope (CRO)

A cathode ray oscilloscope consists of different components. The main component of a cathode-ray oscilloscope (CRO) is a cathode-ray tube. A cathode-ray tube is shown in figure 17.19.

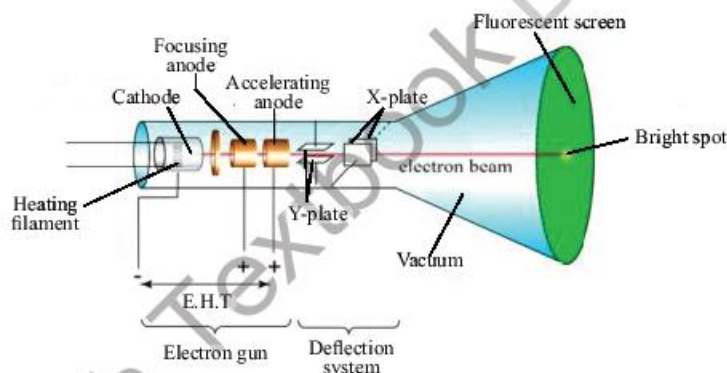

Fig: 17.19 Diagram of CRO

Working:

- The electron gun emits a beam of electrons (i.e. cathode-ray) which is produced by the cathode.
- When this electron beam strikes the fluorescent screen a bright spot is created on the screen. This is due to the reason that the fluorescent screen is coated with a fluorescent salt such as zinc sulfide, a chemical that glows when electrons strike it.

Do You Know!

Fleming's left hand rule



Fig: 17.18.
Oscilloscope

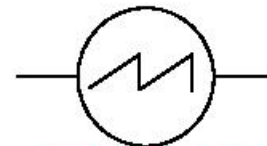

The symbol of CRO

Do You Know!



Before LED and LCD, televisions were inverted, they contained cathode-ray tubes and hence they were assembled in large boxes.

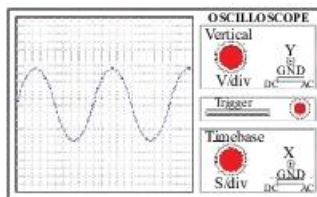

Fig: 17.20.
Front panel of CRO

- The electron gun consists of a grid which is connected to (-ve) potential. It repels the electrons and therefore controls the number of electrons reaching to anode and screen. Thus it controls the brightness of the spot on the screen.
- The anode at (+ve) potential and is used to accelerate the electrons and to focus them into a fine beam.
- The deflecting system consists of X- plates and Y- plates to move the spot on the screen. If it moves fast enough it appears as a line.
- Y-plates cause deflection in vertical direction (up and down) when voltage is applied across them. The vertical deflection of the electron beam can be changed by varying the voltage across the Y- plates.
- X-plates cause deflection in horizontal direction (left and right) when voltage is applied across them. The horizontal deflection of the electron beam can be changed by varying the voltage across the X- plates.

The figure 17.20. shows the front panel of a CRO with the understanding of the important terminals to be used.

The following are the four important controls on an oscilloscope.

1. X-shift
2. Y-shift
3. Time base
4. Y-gain

- X-shift control moves the trace from the left or right of the screen to the centre of the screen.
- Y-shift control moves the trace from the top or bottom of the screen to the centre of the screen. The vertical deflection of the electron beam can be changed by varying the voltage across the Y- plates.
- Vertical deflection (Y-gain) of the electron beam can be amplified by using this control. This is done by varying the voltage applied across the Y-plates of cathode-ray tube. An amplifier circuit amplifies the voltage across the Y-plates in the cathode-ray oscilloscope.



Weblinks

Encourage students to visit below link for Cathode ray oscilloscope
https://www.youtube.com/watch?v=9scohkuTG88&ab_channel=myhometuition



- **Time base:** Horizontal (X) speed of the electron beam on the screen can be adjusted by using this control. This is done by varying the voltage applied across the X-plates of cathode-ray tube. The frequency of the time base is varied by an internal circuit in the cathode-ray oscilloscope which applies an alternating voltage across the X-plates. The time-base actually applies a saw tooth voltage to the X-plates is shown in figure 17.21.

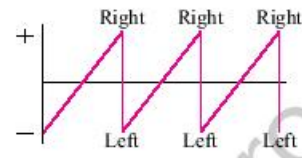

Fig: 17.21.

Uses of the CRO:

The voltage to be measured is connected to the Y-input of the oscilloscope. Two things to be remember,

1. Y-axis is used to measure the voltage.
2. X-axis is used to measure the time.

So, the display on a cathode-ray oscilloscope screen is a graph of voltage against time. Some of the important uses of cathode-ray oscilloscope are given below:

1. Measuring voltage
2. Displaying voltage waveforms
3. Measuring short intervals of time

Self Assessment Questions:

Q1: Which axis is used to measure the voltage?

Q2: What is the function of X-shift?

Q3: Which is the main component of a cathode-ray oscilloscope?

17.10 ANALOGUE AND DIGITAL ELECTRONICS

Analogue electronics deals with the continuously varying quantities. Analogue electronics possesses the data being provided in the form of continuously varying quantities (continuous signals).

Digital electronics deals with the discretely varying quantities. Digital electronics possesses the data being provided in the form of digits (discrete signals).

Basic operations of digital electronics:

Digital electronics based devices uses discrete signals. A digital signal represents two opposite states. These signals either represents a (ON, OFF, HIGH, LOW, OPEN, CLOSE, UPPER, LOWER, PLUS, MINUS, TRUE, FALSE, MAX, MIN) states of a system. There is no



Weblinks

Encourage students to visit below link for How to use CRO to measure Amplitude and Frequency

https://www.youtube.com/watch?v=kh-o1lf4c3Y&ab_channel=TechnicalKnowledgeinElectr

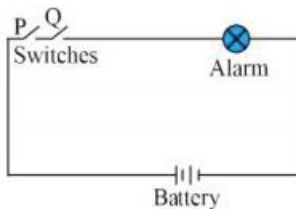

Fig: 17.22.
Diagram of security alarm

intermediate state is possible (allowed). For example, a block diagram of a security alarm which operates through two switches is shown in figure 17.22.

It can be seen clearly from the above diagram that:

- If either switch “P” or “Q” is OFF, the alarm will remain OFF (quite).
- If both switches “P” and “Q” are ON, the alarm will be ON (ringing).

This example could be demonstrated by the following table:

Switch “p”	Switch “q”	Alarm status
OFF	OFF	Quite
ON	OFF	Quite
OFF	ON	Quite
ON	ON	Ringing

The above table represents the logic behind the working of the alarm. In digital electronics, this logic is implemented by “LOGIC GATES”.



A digital MP3 player is an example of a device that uses digital electronics.

Self Assessment Questions:

- Q1: Which types of signals are used by digital electronics based devices?
 Q2: Which component implements the logic?
 Q3: A digital signal has how many states?

17.11 LOGIC GATES

The logic gate is the basic unit of digital logic circuits, there are mainly three basic gates AND, OR, and NOT and these logical gates perform AND, OR, and NOT operations in the digital system.

AND Gate:

An AND gate is a digital circuit that has two or more inputs and a single output. AND gate operates on logical multiplication rules. AND operation using variables A and B is represented “A.B”, here (.) dot is a



logical multiplication sign. Boolean Expression of AND gate: $Y=A.B$

Truth table of AND operation using two input variables		
A	B	$Y = A . B$
0	0	0
0	1	0
1	0	0
1	1	1

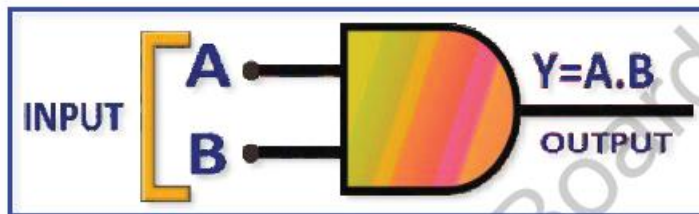

Fig: 17.23 AND Gate using two input variables

Truth Table of AND gate using three input variables A, B, C, and output is Y. If any input is 0, then output Y becomes 0. If all inputs are 1 then output Y becomes 1.

Boolean expression of AND gate is $Y=A.B.C$

Truth table of AND operation using three input variables			
A	B	C	$Y = A.B.C$
0	0	0	0
0	0	1	0
0	1	0	0
0	1	1	0
1	0	0	0
1	0	1	0
1	1	0	0
1	1	1	1



Do You Know!

The truth table is the table that represents the input and output circuit involving two or more variables. The logic circuit's output depends on the logical signals (0 & 1) present at the inputs.



Weblinks

Encourage students to visit below link for The AND gate

https://www.youtube.com/watch?v=oRiWUZRUyKo&ab_channel=EarthPen

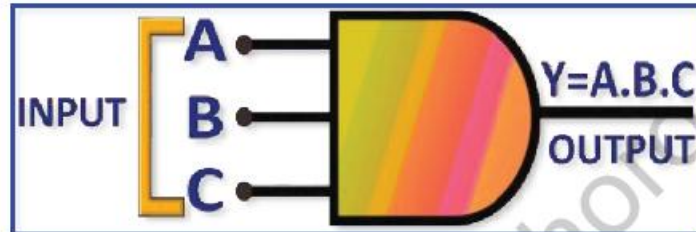

Fig: 17.24 AND Gate using three input variables

OR Gate:

An OR gate is a digital circuit that has two or more inputs and produces a single output, which is the logical OR of all those inputs. The logical OR is represented with the symbol “+”. An OR gate operates on logical Addition rules.

Boolean Expression of OR gate: $Y=A+B$



Weblinks

Encourage students to visit below link for OR gate operations

https://www.youtube.com/watch?v=XLSsEKI-g7A&ab_channel=Physics4students

Truth table of OR gate operation using two input variables		
A	B	$Y = A + B$
0	0	0
0	1	1
1	0	1
1	1	1

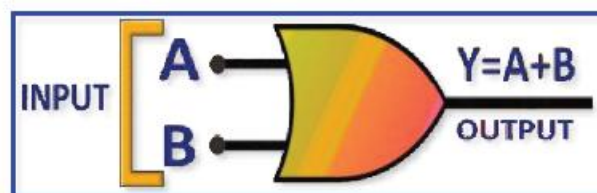

Fig: 17.25 OR Gate using two input variables

Truth Table of OR gate using three input variables A, B, C and output is Y. If any input is 1 then output Y becomes 1 and if all inputs are 0 then output Y becomes 0.

Boolean expression of OR gate is $Y=A+B+C$



Truth table of OR operation using three input variables			
A	B	C	$Y = A+B+C$
0	0	0	0
0	0	1	1
0	1	0	1
0	1	1	1
1	0	0	1
1	0	1	1
1	1	0	1
1	1	1	1

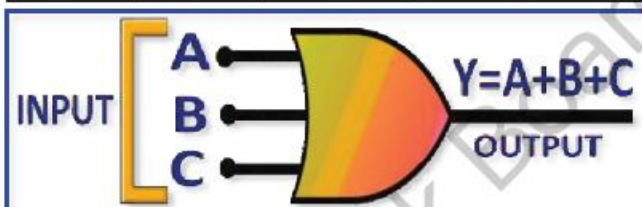

Fig: 17.26 OR Gate using three input variables

NOT Gate:

A NOT gate is a digital circuit that has a single input and a single output. It is also known as INVERTER. The NOT operates complement or invert of any input, it symbolized by complement sign (') Right side on top of the input variable or bar (-) sign on top of the variable.

Boolean expression is NOT gate: $Y = A'$ or $Y = \bar{A}$

Truth table of NOT gate is A is input and $Y = \bar{A}$ is output.

Truth table of NOT gate operation using two input variables	
A	$Y = \bar{A}$
0	1
1	0



Do You Know!

A logical statement that results in form of a digital value, either be True or False, is called a Boolean expression.



Weblinks

Encourage students to visit below link for NOT gate

https://www.youtube.com/watch?v=C_NNbYNY-cw&ab_channel=EarthPen

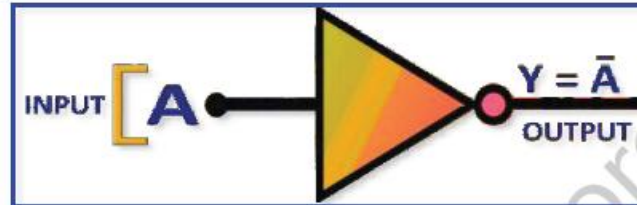

Fig: 17.27 NOT Gate

NAND Gate:

A NAND Gate could construct by connecting a NOT Gate at the output terminal of the AND Gate. Boolean expression of NAND gate is $Y = (A.B)'$ or $Y = \overline{A.B}$.

The Truth table of the NAND gate shows A, B are the inputs and Y is the output. When both inputs are "1", the output, Y is "0". If any one of the inputs is "0", then the output Y is "1".

Truth table of NAND operation using two input variables		
A	B	$Y = \overline{A.B}$
0	0	1
0	1	1
1	0	1
1	1	0

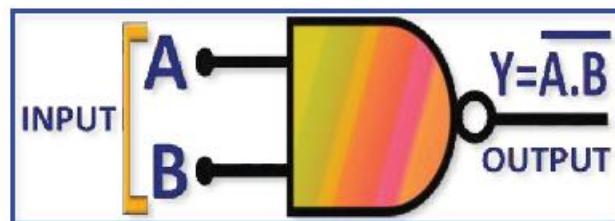

Fig: 17.28 NAND Gate

NOR Gate:

A NOR Gate could construct by connecting a NOT Gate at the output terminal of the OR Gate. The Boolean expression of NOR gate is $Y = (A+B)'$ or $Y = \overline{A + B}$.

Weblinks

Encourage students to visit below link for NAND gate operation

https://www.youtube.com/watch?v=EUwjKBJPtuw&ab_channel=Electrical4U

Weblinks

Encourage students to visit below link for NOR gate operation

https://www.youtube.com/watch?v=E3ry_j80AZA&ab_channel=Electrical4U



The Truth table of the NOR gate shows A, B are the inputs and Y is the output. If both inputs are “0”, then the output, Y is “1”. If any one of the inputs is “1”, then the output Y is “0”.

Truth table of NOR operation using two input variables		
A	B	$Y = \overline{A + B}$
0	0	1
0	1	0
1	0	0
1	1	0

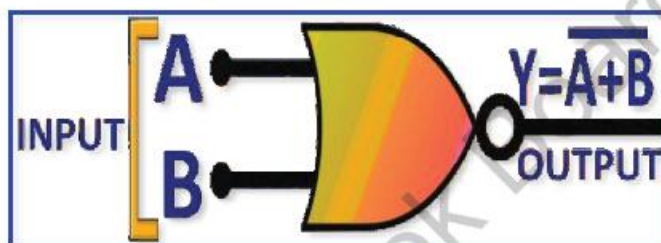

Fig: 17.29 NOR Gate

USE OF LOGIC GATES:

A seat belt alarm system:

In Figure 17.30, an AND gate is used in a simple automobile seat belt alarm system to detect when the ignition switch is on and the seat belt is unbuckled. If the ignition switch is on, a HIGH is produced on input A of the AND gate. If the seat belt is not properly buckled, a HIGH is produced on input B of the AND gate. Also, when the ignition switch is turned on, a timer is started that produces a HIGH on input C for 30 s. If all three conditions exist that is, if the ignition is on and the seat belt is unbuckled and the timer is running—the output of the AND gate is HIGH and an audible alarm is energized to remind the driver.



Web links

Encourage students to visit below link for Logic gates and its real-world applications

https://www.youtube.com/watch?v=Sb5iU5HDvRc&ab_channel=CognitiveLearners

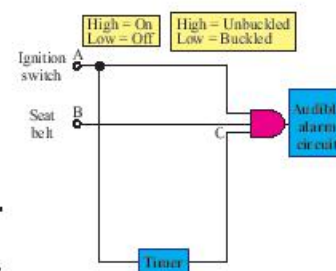

Fig: 17.30
A simple seat belt alarm circuit using an AND gate.

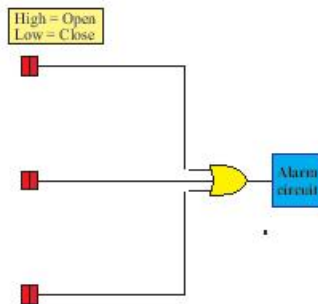

Fig: 17.31
A simplified intrusion
detection system
using an OR gate.

Intrusion detection and alarm system:

A simplified portion of an intrusion detection and alarm system is shown in Figure 17.31. This system could be used for one room in a home a room with two windows and a door. The sensors are magnetic switches that produce a HIGH output when open and a LOW output when closed. As long as the windows and the door are secured, the switches are closed and all three of the OR gate inputs are LOW. When one of the windows or the door is opened, a HIGH is produced on that input to the OR gate and the gate output goes HIGH. It then activates and latches an alarm circuit to warn of the intrusion.

Self Assessment Questions:

- Q1: What is a logic gate?
- Q2: Which gate is used to invert the input?
- Q3: Write the Boolean expression of an OR gate?



SUMMARY

- Electronics comprises the physics, engineering and technology.
- Electronics has applications that deal with the emission, flow and control of electrons in vacuum and matter using different devices.
- Analogue are those quantities which change continuously with time.
- Digital are those quantities which change discretely (in steps) with time.
- Analogue electronics possesses the data being provided in the form of continuously varying quantities (continuous signals).
- Digital electronics possesses the data being provided in the form of digits (discrete signals).
- Thermionic emission is the emission of electrons from a hot metal surface.
- An electron gun made the electrons to travel in straight lines like a beam.
- Electrons and their beams can be deflected by electric fields.
- Electrons and their beams can be deflected by magnetic fields.
- The Cathode-ray oscilloscope is an electronic device which can be used to measure voltages, study wave forms and measure short intervals of time.
- Cathode rays are beam of electrons that are produced by thermionic emission in a vacuum tube.
- Cathode rays can be deflected by electric and magnetic fields.
- Logic gates are used to implement the logic.
- There are different types of logic gates, like NOT, OR, AND, NOR and NAND gates.
- A truth table gives all the possible inputs and outputs of a logic circuit.



CONCEPT MAP

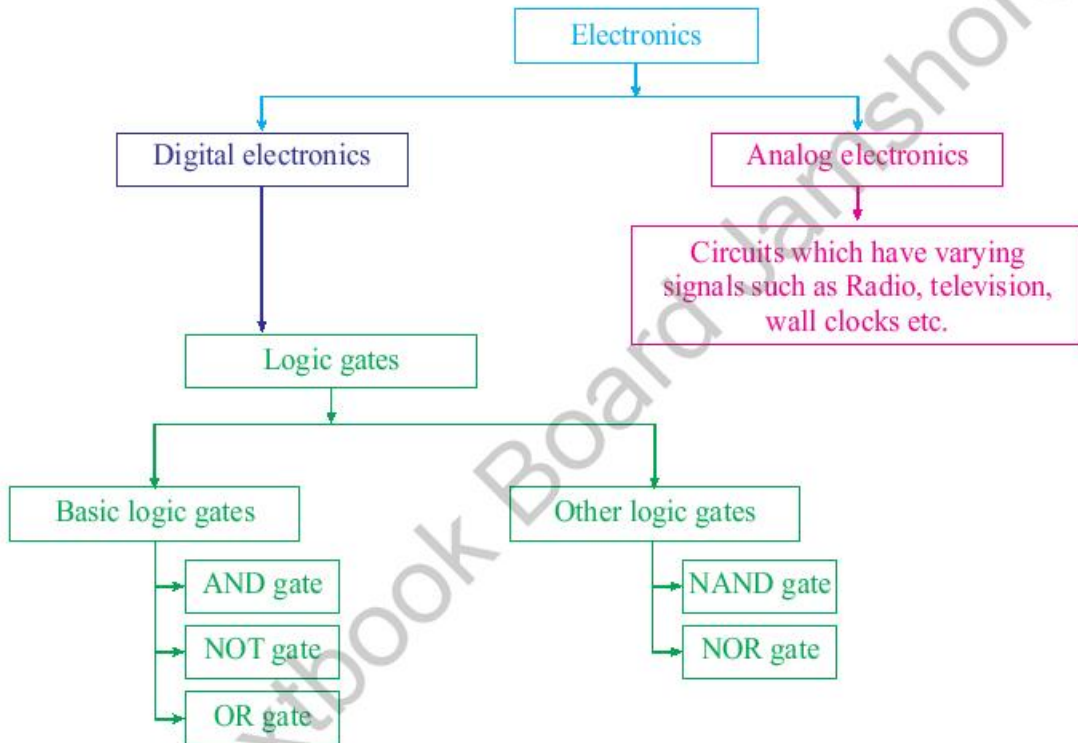



Section (A) Multiple Choice Questions (MCQs)

- Metals are good conductors of electricity because they have free:
(a) Electrons (b) Protons (c) Neutrons (d) Photons
- The continuous flow of electrons is made possible by a device called:
(a) Cathode (b) Electron gun (c) Anode (d) Filament
- The electric field can be detect:
(a) Photon (b) Neutron (c) Proton (d) Electron
- If the direction of magnetic field is reversed, the direction of force is:
(a) Reversed (b) Not reversed (c) May or may not reversed (d) None of these
- The process of emission of electrons from the hot metal surfaces is called
(a) Plastic emission (b) Thermionic emission
(c) Static emission (d) Current emission
- If input of a NOT gate is "1" then its output is:
(a) 1 (b) 0 (c) may be 1 or may be 0 (d) None of these
- The Boolean expression of an AND gate is:
(a) $A \cdot B$ (b) $A + B$ (c) $A \times B$ (d) None of these.
- Electronics comprises the:
(a) Physics (b) Engineering (c) Technology (d) All of these
- The Boolean expression of an OR gate is:
(a) $A \cdot B$ (b) $A + B$ (c) $A \times B$ (d) None of these.
- The cathode ray carry
(a) positive charge (b) neutral (c) negative charge (d) positrons

Section (B) Structured Questions

- Give an example showing that the world is shifting from low-tech electrical appliances to high-tech electronic appliances
- (a) Write any three advantages of Digital electronics (devices) over analogue electronics devices.
(b) Define the role of vacuum tube in electronics.
- What is the function of a 'DAC'?
- What makes the cathode give off electrons?
- (a) Demonstrate the process of thermionic emission by diagram?
(b) Will the process of thermionic emission still occurs, if air is in the tube instead of having vacuum in it?
- Why the cathode repel electrons?
- Write any two properties of cathode rays.



8. (a) Will there be any change in the properties of cathode rays if the gas in the tube is changed?
(b) Will there be any change in the properties of cathode rays if the metal used as cathode is changed?
(c) Name any two devices that uses an electron beam?
(d) Cathode rays lead the discovery of which particle?
9. State and explain the phenomenon of the production of an electron beam by an electron gun?
10. Is there any change occurs in the direction of an electron beam when it passes through an electric field. Explain?
11. How the beam of electron produced by the electron gun can be directed to a specific target?
12. Demonstrate by a diagram the deflection of electron beam by an electric field.
13. (a) What happens to the energy of electron beam when it passes through a magnetic field?
(b) Is there any change in the speed of electron beam as it passes through a magnetic field.
14. Give any three effects of deflection of electron beam by a magnetic field.
15. Explain the function of following parts of a cathode-ray oscilloscope.
 - (a) The fluorescent screen.
 - (b) The cathode.
 - (c) The anode.
 - (d) The Y-plate.
16. Explain how the beam of electrons is produced inside the cathode-ray oscilloscope.
17. Explain what makes the electrons accelerate from the cathode towards the anode?
18. (a) Explain the term "LOGIC" by giving a suitable example?
(b) Name the component which implements logic in digital electronics.
19. Explain is there any intermediate state possible?
20. (a) Give the symbol of a NAND gate.
(b) Give the truth table for AND gate.
21. (a) Describe the logic operation of an inverter?
(b) Produce the truth table for an OR gate?
22. (a) Which two logic gates will give an output of 1 with inputs of 1 and 0 ?
(b) Give the symbol of a NOR gate?
(c) Give the truth table of a NOR gate?

Unit - 18

Information and Communication Technology

Students Learning Outcomes (SLOs)

After learning this unit students should be able to

- Describe the components of information technology.
- Explain briefly the transmission of
 - electric signals through wires
 - radiowaves through air
 - light signals through optical fibres
- Describe function and use of fax machine, cell phone, photo phone and computer.
- Make a list of the use of E-mail and internet.
- Describe the use of information storage devices such as audio cassettes, video cassettes, hard discs, floppy, compact discs and flash drive.
- Identify the functions of word processing, data managing, monitoring and controlling.

We are in the era of ICT. There was a time when the telephone was the only way of communication.

Nowadays, people communicate with one another by mobile phone, fax, computer, and the internet. These sources have reduced distances and linked the whole world together in a single network. In this chapter, we will look at some of the fundamental phenomena and technologies that are employed in today's information and communication technology (ICT) systems.



18.1 INFORMATION AND COMMUNICATION TECHNOLOGY

Processed data is termed information in computers. A computer analyses data and extracts information. Sound, image, and digital data are used to communicate this information to remote locations. An electronic-based system for transmitting, receiving, processing, and retrieving information is known as Information and Communication Technology (ICT). Telecommunications and information technology have been merged to become ICT. The above terms can be defined separately as:

1. Information technology is the scientific approach for storing information, organizing it for optimal use, and communicating it to others.
2. The process of transmitting information over long distances is known as telecommunication.

ICT refers to the scientific techniques and tools to store, process, and transport large volumes of information in a matter of seconds using electronic devices.

18.2 COMPONENTS OF COMPUTER BASED INFORMATION SYSTEM (CBIS)

Five components must come together to create a CBIS (see Fig.18.1). Now we will briefly discuss them.



Do You Know!

Input hardware:

The devices that are used to command the data to the computer are known as input hardware devices like: mouse, joy stick, keyboard.

Output hardware:

The devices that are used to display processed data are known as output hardware like as loudspeaker, screen, printer

1. **Hardware is machinery.** This comprises the CPU and its supporting hardware. Input/output, storage, and communication devices are examples of essential equipment.
2. **Software:** Software includes computer applications. They tell the CBIS's hardware how to process data and turn it into meaningful information. Programs are usually saved on a chips or tape.
3. **Data:** Programs utilize data to provide helpful information. It might be a phrase, picture, or figure that has special significance. Data, like programmes, are usually saved on chips or tape until needed by the computer.



4. **Procedures:** The guidelines for creating and using information systems. These are in user manuals and papers. From time to time, these rules or techniques may be revised. In order to accommodate these adjustments, the information system must be adaptable.

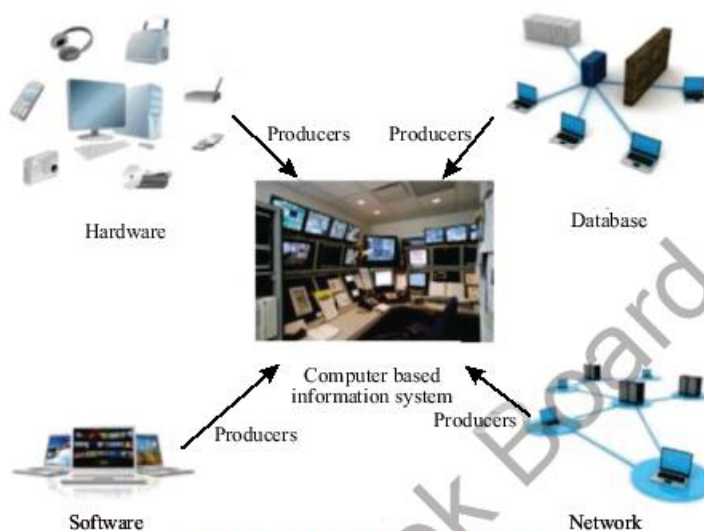

Fig: 18.1 Components of CBIS

5. **People:** A CBIS is useless without individuals who can impact the success or failure of information systems. People develop and maintain the software, enter data, and construct the hardware that makes a CBIS work. People write the processes and ultimately decide the CBIS's effectiveness.

18.3 FLOW OF INFORMATION

Electronic and optical equipment can be used to transfer information from one place to another place, which is called flow of information. When you use a phone, electrical impulses are used to transmit data via cables. Radio, television, and mobile phones provide information by electromagnetic waves or light via optical fibers. As radio waves move through different layers of the Earth's atmosphere, they keep getting bent. As a result, the signal gets weaker, making it hard for people to get it from a long distance away. Microwaves are not refracted in the same

Do You Know!

System software:
System software is a type of computer program that is designed to run a computer's hardware and application programs.

Application software:
Application software is a type of computer program that performs a specific personal, educational, and business function.



Do You Know!

Transducer is a device that convert one form of energy into other form of energy

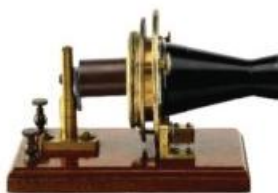

Fig: 18.3 (a)
First telephone

Bell's telephone transmitter (microphone) consisted of a single permanently magnetized bar magnet having a small coil or bobbin of fine wire surrounding one pole, in front of which a thin disc of iron was fixed in a circular.

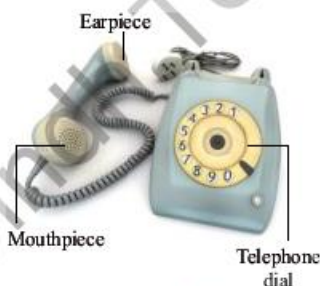

Fig: 18.3 (b)
Telephone

way as radio waves. It is because they are used to communicate with satellites.

Figure 18.2 shows a communication system. The transmitter, transmission channel, and receiver are three of the most important parts of any communication system.

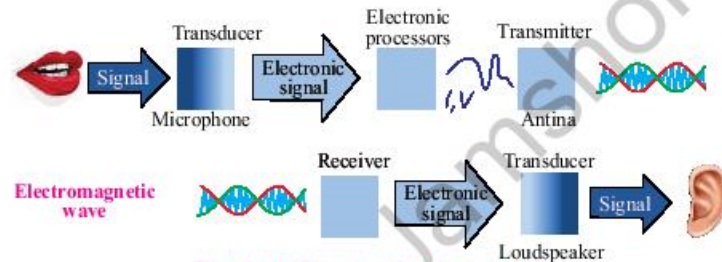

Fig: 18.2 Communication system

The input signal is processed by the transmitter. The transmission channel is the medium used to transmit the signal. Wires or coaxial cables may be used in the same way as radio-wave and optical fiber cables. In other words, the signal power gets weaker as you get farther away from the source. The transducer receives the output signal from the receiver after it has been processed. To compensate for transmission loss, the receiver may amplify the input signal.

18.4 TRANSMISSION OF ELECTRICAL SIGNAL THROUGH WIRES

In 1876, Alexander Graham Bell created a simple and basic telephone system to transmit audio as an electrical signal. An electric coil is attached to a vibrating diaphragm which is made of metal. Diaphragms are used in modern telephones to convert voice into electrical signals for transmission. The mouthpiece and the earpiece are two elements of the telephone system; Fig.18.3.

A thin metal diaphragm and carbon granules are found in the mouthpiece and receiver, respectively. The diaphragm vibrates as we speak through the mouthpiece. An electrical current may travel through the wire because the diaphragm vibrates slightly, compressing the carbon.

At the opposite end of the line, the receiver reverse this procedure. An electromagnet in the receiver generates a



changing magnetic field as a result of the electrical current. As a result of the receiver's thin metal diaphragm vibrating due to the magnetic field, sound is produced.

18.5 TRANSMISSIONS OF RADIOWAVES THROUGH SPACE

Cables or radiowaves may be used to transmit electrical signals representing data from a microphone, TV camera, or computer. Audio frequency (AF) signals may be used to send data directly via wire. Electromagnetic waves, on the other hand, must be used to transmit information over a long distance.

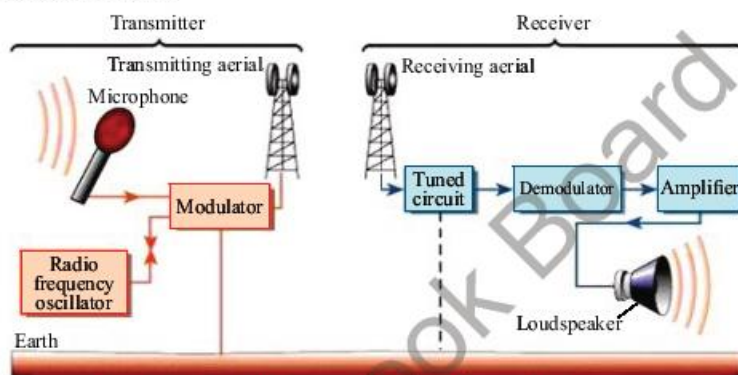

Fig. 18.4: Radio transmission and receiving system

The microphone converts the radio station's sound waves into electrical impulses. The transmission aerial consists of two metal rods, and these signals are subsequently fed into the antenna. Electromagnetic radiowaves are produced when the charges on the transmission antenna vibrate in response to electrical signals.

The modulated signal is selected and amplified by the receiver at the other end. In order to get at the information signal, we need to use the demodulator, which extracts it. In Fig. 18.5, we see a radio broadcast and reception system in action.

Fax machine

A fax machine; Fig. 18.6 is a need for many enterprises across the globe. There are two essential functions in the use of fax machines: scanning the page and transmitting the resulting electronic signals over telephone line.

Do You Know!

Satellites communicate by using radio waves to send signals to the antennas on the Earth.



Antenna or aerial



Fig: 18.5 Radio



**Fig: 18.6
Fax machine**



An internal printer on the receiving system is used to print out a copy of the transmitted message once it has been converted by the software.

Cell phone

In mobile phones, radio technology is used; Fig. 18.7. It's a sort of radio that allows for two-way communication between users. There are radio transmitters and receivers built inside the mobile phone's internal components. To communicate, it uses radio waves to transmit and receive.



Fig. 18.7
Mobile phone

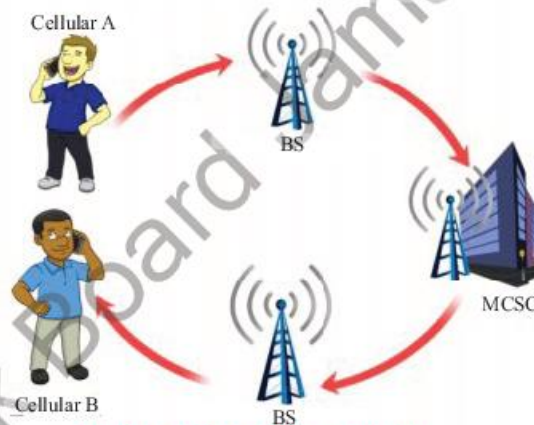

Fig. 18.8. Cell phone network

When a mobile phone user makes a phone call, the sound waves of the caller are transformed into radiowaves. As soon as this signal is received, it is routed to the caller's local base station and given a unique radio frequency. The receiver's base station receives this signal through mobile switching center (MSC), which transmits it to the transmitter. Afterwards, the caller's mobile phone is connected to the call. The radiowaves are converted into sound once again by the mobile receiver as shown in figure 18.8.

Photo phone

Figure 18.9 depicts a more modern form of a photo or video phone. It is possible for users to view each other's faces, unlike the traditional phone. To contact our friends or family members, we just hit the pad with their picture and their phone number. As a result, we are able to connect with our family and friends through camera phone with their actual appearances.



Fig. 18.9
Photo phone



18.6 TRANSMISSION OF LIGHT SIGNALS THROUGH OPTICAL FIBRES

Visible light waves are substantially higher in frequency than radio waves. This implies that light beams can convey information faster than radiowaves or microwaves. An optical fibre was employed as a transmission path. A low-refractive-index optical fibre is a tiny strand of high-quality glass that absorbs less light. A bundle of optical fibres of human hair-thick glass fibres.

Light entering the core of an optical fibre travels straight and meets the inner wall (cladding). If the cladding incidence angle is below the critical angle, some light escapes the fibre optics and is lost; Fig. 18.10. A critical angle of incidence is one where all light is reflected into the fibre optics. It then proceeds in a straight path until it meets the inner wall again, and so on.

The benefit of optical fibre is that it can be used to transmit very large amounts of data across great distances with little loss of quality. This characteristic of fibre optics separates it from wire-based systems. Whenever electrical signals are transferred across wires, the signal loss rises in direct proportion to the increase in data rate delivered. As a result, the signal's range is reduced.

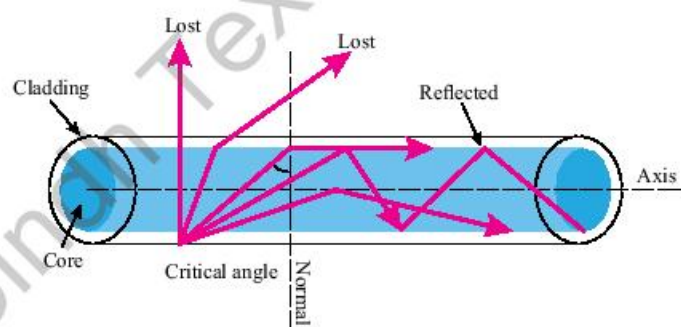

Fig: 18.10.

Light entering a glass rod at greater than the critical angle is trapped inside the glass



Do You Know!

(One common misconception is that most of our information is transmitted through satellites, but fiber optic cables actually form the backbone of the internet, transmitting about 99% of all data.) Today, there are over 420 submarine cables in service, stretching over 700,000 miles (1.1 million km) around the world.





Do You Know!

Supercomputer is a computer that performs at or near the highest operational rate for computers. Traditionally, supercomputers have been used for scientific and engineering applications that must handle massive databases, do a great amount of computation or both.



Do You Know!

ENIAC, in full Electronic Numerical Integrator and Computer, the first programmable general-purpose electronic digital computer, built during World War II by the United States. American physicist John Mauchly, American engineer J.



When compared to single-mode cables, the thickness of each optical fibre in a multi-mode cable is about 10 times greater. The term "multiple-mode" comes from the fact that light beams may flow through the core in several ways. Multi-mode cables can only transmit data over small distances and are used to connect computer networks together.

Computer

A computer processes, stores, and displays data. Hardware and software are two components that are fundamental to the operation of a computer. "Hardware" is a physical component of computer. CPU, monitor, keyboard, and mouse are a few examples. CPU, a microprocessor, is the most important component of hardware. It is the "brain" of computer the unit that processes instructions and calculates results. Software informs hardware what to do. A word processing program enables you type letters. The operating system (OS) is the software that governs the functioning of your computer and any other connected devices. Windows and Linux are well-known operating systems.

Today, computers are employed in almost every field, including medicine, engineering, weather forecasting, transportation, and shopping malls. Most individuals now use laptops; Fig 18.11. It is easy to carry a laptop with you when you need to work on a computer since they're compact and light.



Fig: 18.11
Laptop

Fig: 18.12. Parts of a computer



18.7 INFORMATION STORAGE DEVICES

Storage device is a device that can be used to store information in a computer. Storage devices use electronics, magnetism, and laser technology in different ways to store information.

Primary Memory

Primary memory is made up of integrated circuits (ICs) that a processor or computer can access immediately. Random Access Memory (RAM) is a region in the memory where running programmes and services may be accessed by the CPU. Whenever you turn off your computer, you lose all of your RAM's data. The second part of memory is called read-only memory (ROM), which is a type of storage medium that stores data on personal computers (PCs) and other electronic devices in a way that doesn't change it. Among its many functions, it handles the majority of a computer's input and output and stores any program or software instructions that are loaded during bootup.



Do You Know!

Primary memory is also known as primary storage or the main memory.

Secondary Storage Devices

They are usually the secondary storage memory, it can also be used to store other types of data. It is used to keep the data in the computer for a long time. When we open a software, data is transferred from secondary to main storage. Audio-video cassettes, hard discs, USBs, memory cards are the few examples of secondary storage devices.



Do You Know!

The magnetic fields weaken the data will also be lost.

Audio And Video Cassettes

These devices are based on magnetism. Audio cassettes consist of a tape of magnetic material on which sound is recorded in a particular pattern of a magnetic field; Fig 18.13 For this purpose, microphone changes sound waves into electric pulses, which are amplified by an amplifier. Magnetic tape is moved across the head of audio cassette recorder which is in fact an electromagnet; Fig 18.13.



Fig: 18.13
Audio cassette



Do You Know!

In 1877 Thomas Edison, invented the phonograph. It was beginning of sound recording and reproduction.



Phonograph

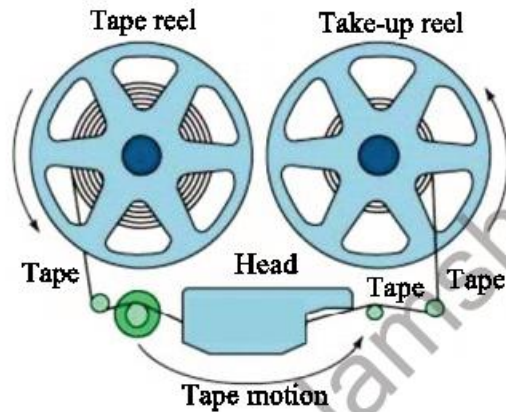

Fig: 18.14. A magnetic tape storage mechanism



**Fig: 18.15
Video cassette**

Thus, magnetic tape is magnetized in a particular pattern according to rise and fall of current. In this way, sound is stored in a specific magnetic pattern on this tape.

To produce the sound again, the tape is moved past the playback head. Changes in magnetic field on the tape induce alternating current signals in the coil wound on the head.

These signals are amplified and sent to the loudspeakers which reproduce the recorded sound. In video tape/cassettes; Fig.18.15, pictures are recorded along with sound.



**Fig: 18.16
Floppy disk**

Magnetic Disks

There are different types of magnetic disks coated with a layer of some magnetic material. The read/write head of disks are similar to the record replay head on a tape recorder. It magnetizes parts of the surface to record information. The difference is that a disk is a digital medium— binary numbers are written and read.

A floppy disc; Fig.18.16 is a small magnetically sensitive, flexible plastic wafer housed in a plastic case. It is coated with a magnetic oxide similar to the material used to coat cassettes and video tapes. Most personal computers include at least one disk drive that allows the computer to write it and read from floppy disk.



**Fig: 18.17
Hard disk**

Hard Disk

Most users rely on hard disks as their primary storage devices. A hard disk is a rigid, magnetically sensitive disk



that spins rapidly and continuously inside the computer chassis or in a separate box connected to the computer housing; Fig.18.17. This type of hard disk is never removed by the user. A typical hard disk consists of several platters, each accessed via a read/write head on a moveable arm.

Compact Disc (CDs)

It's a moulded plastic disc with tiny "pits" and "lands" that store digital data. Pits are CD's spiral tracks and lands lie between them ;Fig. 18.18 (a, b) A laser beam scans the disc to read data. CD pits and lands reflect laser light differently. This pattern of pit and land light reflection is transformed to binary data. Pits signify '1' and '0'. CDs can contain 680 MB of data. A DVD can contain 17GB of data, the same as a CD.

Flash Drive

It is an electronics device and has Integrated circuits (ICs) that store data. A flash drive may transfer data between computers; Fig 18.19. Many of these little devices can hold a year's load of schoolwork. We may connect one to our key chain, collar, or book bag. Because of flash derive; we don't need to bring a hard drive or laptop with us when we move around the world.

18.8 Word Processing, Data Management and Control

Word processing is such a use of computer through which we can write a letter, article, book or prepare a report. Word processing is a computer program. Using this program we can develop any document, see it on the screen after typing. We can edit the document, add some new text or delete the previous text or make amendments in it. We can move text from one page to another, even from one document to another. Document can be stored in memory and its print can also be taken. By means of modern word processing, we can write it in different styles and in different colours. We can also use graphics.

Some other features of word processing are shown below in the icon of word processing:



Fig: 18.18 (a)
Compact disk

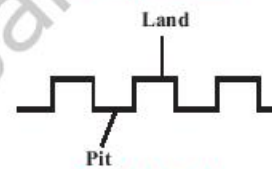

Fig: 18.18 (b)



Fig: 18.19
Flash drive

Do You Know!

In 1956, IBM's Data Processing Division in southern San Jose, Ca transported the first hard-drive that only held a whopping 5 megabytes of storage.





Do You Know!

National Database and Registration Authority (NADRA),

biggest data managing authority of Pakistan was established on 10 March 2000. That manage the data of citizens through the internet by issuing computerized identity card and Form B.



Fig: 18.20
Barcode scanning

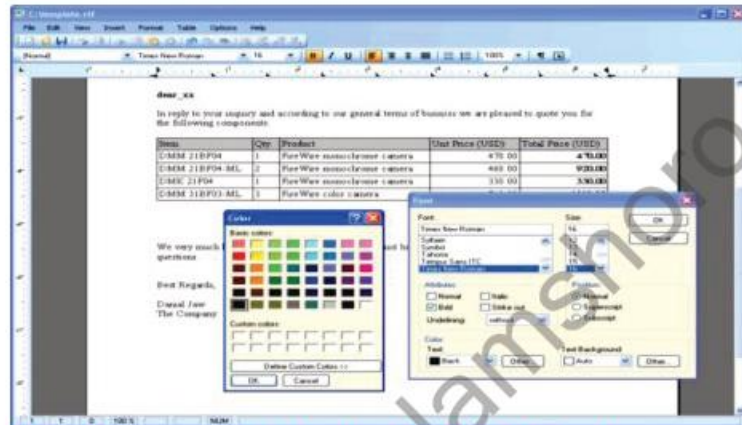

Data Management – Monitoring And Control

To collect all information regarding a subject for any purpose and to store them in the computer in more than one inter linked files which may help when needed, is called 'data managing'.

The educational institutions, libraries, hospitals and industries store the concerned information by data management. Additions and deletions are made in the data according to the requirement, which help in the improvement of the management of the institutions.

In big departmental stores and super markets, optical scanners are used to read, with the help of a Laser Beam, the barcodes of a product which indicate the number at which this product is recorded in the register; Fig.18.20. In this way, the detail about its price is obtained. The central computer monitors the bills and the related record of the sold goods. It also helps placing the order of goods being sold in a large quantity and to decide about less selling goods.

18.9 Internet

When many computer networks of the world were connected together, with the objective of communicating with each other, Internet was formed. In other words, we can say that Internet is a network of networks, which spreads all across the globe. Initially, the size of Internet was small. Soon, people became aware of its utility and advantages and within short span of time, numerous computers and networks got themselves



connected to Internet. Its size has increased multi folds within few years. Today Internet comprises of several million computers. There is hardly any country of the world and important city of the country, where Internet is not available.

A conceptual diagram of Internet is illustrated in Fig.18.21.



Fig: 18.21. Schematic diagram of internet

Internet is basically a large computers network, which extends all across the globe. In Internet, millions of computers remain connected together through well-laid communication system.

Recall that telephone communication system is well-defined, time proven system. Internet makes use of this system and many other systems to connect all the computers. Thus like a telephone connection, any computer of any city can establish a connection with any other computer of any other city and exchange data or messages with it.

Internet Services

The main services used on the internet include:

- Web browsing - this function allows users to view webpages.
- E-mail - Allows people to send and receive text messages.

Browsers

A browser is an application which provides a window to the Web. All browsers are designed to display the pages of information located at Web sites around the world. The



Do You Know!

January 1, 1983 is considered the official birthday of the Internet. Prior to this, the various computer networks did not have a standard way to communicate with each other. A new communications protocol was established called Transfer Control Protocol/Internet Protocol (TCP/IP).



Do You Know!

HTTP, in full **Hyper Text Transfer Protocol**, standard application-level protocol used for exchanging files on the World Wide Web.



Internet explorer



Google Chrome



Mozilla Firefox

Fig: 18.22.
Icons of different web
browsers



Fig: 18.23.
Icons of Electronic mail

most popular browsers on the market today include Internet Explorer, The World, Opera, Safari, Mozilla Firefox, Chrome, etc; Fig. 18.22.

We can search anything through search engine like Google Chrome, Internet Explorer, Mozilla Firefox, etc.

Electronic Mail

One of the most widely used application of internet is electronic mail (or e-mail), which provides very fast delivery of messages to any enabled site on the Internet. Communication through e-mail is quicker and more reliable. Through our e-mail, we can communicate with our friends and institution with more ease and pace. Some advantages of e-mail are as follows:

Fast Communication:

We can send messages anywhere in the world instantly.

Cost Free Service:

If we have an internet access, then we can avail the e-mail service free of cost.

Simple to Use:

After initial set up of e-mail account, it is easy to use.

More Efficient:

We can send our message to many friends or people only in one action.

Pictures or other files can also be sent through e-mail. Internet has proved to be very beneficial to us. Here is the list of use of internet.

- i. Faster Communication
- ii. Big Source of Information
- iii. Source of Entertainment
- iv. Access to social media
- v. Access to Online Services
- vi. E-commerce
- vii. E-Learning



SUMMARY

- The scientific method used to store information, to arrange it for proper use and to communicate it to others is called information technology.
- The methods and means that are used to communicate information to distant places instantly is called telecommunication.
- Information and Communication Technology (ICT) is defined as the scientific methods and means to store, process and transmit vast amounts of information in seconds with the help of electronic equipment.
- Flow of information means the transfer of the information from one place to another through different electronic and optical equipments.
- In telephone, information can be sent through wires in the form of electrical signals. In radio, television and cell phone information can be sent either through space in the form of electromagnetic waves or it can be sent through optical fibres in the form of light signals.
- There are five parts that must come together in order to produce a Computer-Based Information System (CBIS). These are called the components of information technology. These are: hardware, software, data, procedures and people.
- Information storing devices store the information for later use and benefits. These include audio cassettes, video tapes, compact discs, laser disks, floppy disks, and hard disks.
- Telephone changes sound into electrical signals and sends these signals to the receiver. The receiver changes the electrical signals again to sound by a system fitted in the receiver.
- Mobile phone is a sort of radio with two-way communication. It sends and receives the message in the form of radiowaves.
- Fax machine is the means to send the copy of documents from one place to another through telephone lines.
- Radio is an instrument which transmits the sound waves to us.
- Computer is an electronic computing machine that is used for adding, subtracting and multiplying.
- Hardware refers to the parts of a computer that we can see and touch i.e., key board, monitor, printer, scanner, mouse, etc.



- The most important piece of hardware is the central processing unit (CPU). It is the “brain” of computer—the part that translates instructions and performs arithmetic calculations.
- Software refers to the instructions, or programs, that are installed in the hardware to perform different tasks. Window and Linux Operating Systems (OS) are examples of softwares.
- Word processing is such a use of computer through which we can write a letter, prepare reports and books. By means of this, we can develop any document and see it on the screen after typing.
- To collect information for a special purpose and to store it in a computer in a file form, which may help at times when needed, is called data managing.
- Internet is a network of large number of computers which is major source of information and world communication.



CONCEPT MAP

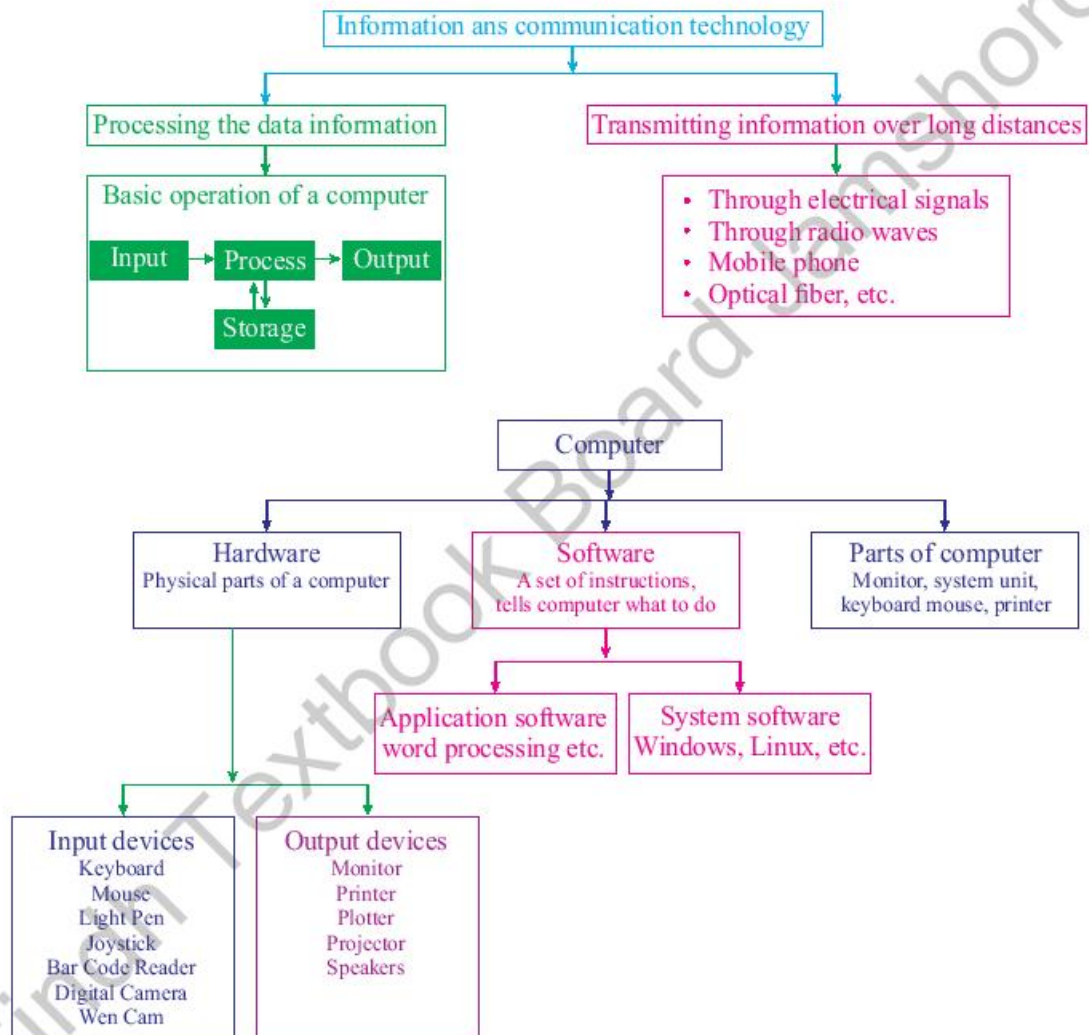



Section (A) Multiple Choice Questions (MCQs)

1. Another name for a supercomputer is a:
a) High-performance computer b) Maxi computer
c) Mainframe computer d) None
2. Input, processing, output, and storage are collectively referred to as:
a) Information processing cycle. b) Software life cycle.
c) Hardware life cycle. d) Information technology.
3. _____ is the output from a computer that ranks from processing input data
a) Data b) Information
c) Computer d) Mouse
4. Which one of the following is not considered as a system software?
a) Assembler b) Interpreter
c) Compiler d) Tally
5. Which of the following is suitable for connecting different computers in an organized manner within an office building?
a) MAN b) WAN
c) ANN d) LAN
6. A computer program that translates one program instruction at a time into machine language is called?
a) Interpreter b) CPU
c) Compiler d) Simulator
7. The name given to a sequence of instructions in a computer language, to get the desired result is?
a) Program b) Decision table
c) Pseudo code d) Algorithm
8. USB stands for
a) Ultra Serial Bus b) Unlimited Structured Bit
c) Universal Serial Bus d) Unified Status Bus
9. Which is the extension not suitable to an ms-word file
a) .doc b) .docx
c) .rtf d) .jpeg
10. ICT stands for
a) Information and Communications Technology
b) Integrated Circular Technology
c) Intensive Computer Techniques
d) Interfacing Computer Theories



Section (B) Structured Questions

1. What is difference between data and information?
2. What do you understand by Information and Communication Technology (ICT)?
3. What are the components of information technology? Clearly indicate the function of each component.
4. Differentiate between the primary memory and the secondary memory.
5. Name different information storage devices and describe their uses.
6. Explain briefly the transmission of radiowaves through space.
7. How light signals are sent through optical fibre?
8. What is computer? What is the role of computer in everyday life?
9. What is the difference between hardware and software? Name different softwares.
10. What do you understand by the term word processing and data managing?
11. What is Internet? Internet is a useful source of knowledge and information. Discuss.
12. Discuss the role of information technology in school education.
13. Why optical fibre is more useful tool for the communication process?
14. Which is more reliable floppy disk or a hard disk?
15. What is the difference between RAM and ROM memories?

.....

Unit - 19

Atomic Structure

Students Learning Outcomes (SLOs)

After learning this unit students should be able to

- Describe the structure of an atom in terms of a nucleus and electrons
- Describe the evidence for the nuclear model of the atom
- Describe the composition of the nucleus in terms of protons and neutrons
- Explain that number of protons in a nucleus distinguishes one element from the other.
- Represent various nuclides by using the symbol of proton number Z , nucleon number A and the nuclide notation ${}_Z^AX^A$
- Use the term isotope

There are over 100 different kinds of atoms. Among 92 of them occur naturally, while the remainder is manufactured. Atoms are mostly empty spaces. The nucleus of an atom is dense and contains nearly all of the atomic mass. Electrons contribute very little mass to the atom (it takes 1,836 electrons to equal the mass of a proton) and orbit so far away from the nucleus that each atom is 99.9% free space.





Matter composes everything such as bacteria, animals, and plants as well as non-living things such as tables, water, planets, and stars. But the building blocks of matter are atoms. Thus, the composition of everything, living or non-living, atoms.

What the exactly atom is? What is it composed of? Let us study atoms and the structure of atoms in detail in this unit.

19.1 ATOM AND ATOMIC NUCLEUS

The structure of an atom in terms of a nucleus and electrons

Atom is the smallest unit into which matter can be divided without releasing electrically charged particles. This is too small to be seen with any ordinary microscope. However, by shooting tiny atomic particles through atoms, scientists have developed a structure model. The simple Rutherford's atomic model given below; Fig 19.1 is often used to explain the basic structure of an atom.

Every atom is composed of two parts;

- The central hard-core of an atom is the nucleus which is the small, dense region consisting of closely packed protons and neutrons.
- Around the nucleus, electrons revolve at high speed. The number of particles (electrons and protons) depends on the type of atom.

Most of the atom is empty space. The rest comprise a positively charged nucleus surrounded by negatively charged orbiting electrons. The nucleus is tiny and dense compared with the electrons. Electrons are bound by a positively charged nucleus with the electrostatic force.

Nuclear Model of the Atom

Nobody has seen an atom. To visualize the processes in the atom, various models have been proposed. Rutherford put forward one of the earliest model of the nucleus, which he derived from experiments carried out by Geiger and Marsden. Let us discuss this experiment and its results in detail.

Geiger and Marsden α - scattering Experiment

Geiger and Marsden, the two scientists, used a beam of positively charged α - particles to bombard a thin gold

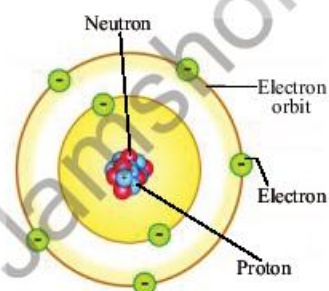

Fig: 19.1
The structure of an atom



Do You Know!

The word "atom" comes from the Greek word "undivided." The name comes from the 5th century BCE Greek philosopher Democritus, who believed matter consisted of particles that could not be divided into smaller particles. For a long time, people believed atoms were the fundamental "undividable" unit of matter.

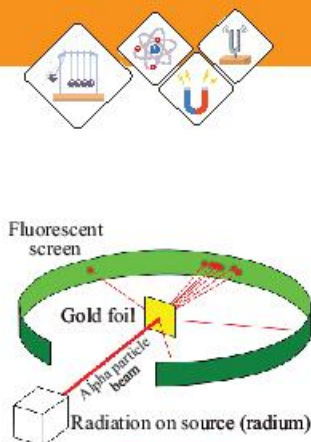

Fig: 19.2
Experimental arrangement of Geiger and Marsden α -scattering

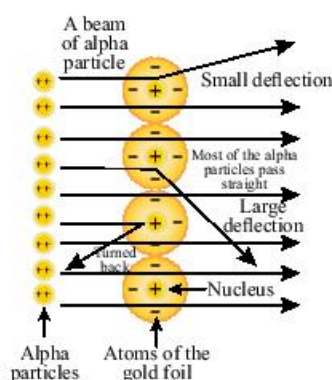

Fig: 19.3.
Scattering of α -particles by a nucleus

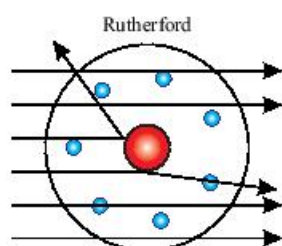

Fig: 19.4
Close up view of scattering of α -particles by a nucleus

foil placed in a vacuum surrounded by a ring-shaped fluorescent screen. After bombarding the foil, the scattered α - particles were detected using a rotating detector. When α - particles hit the screen of light was observed through the detector; Fig 19.2.

Geiger and Marsden found quite unpredicted experimental results that most of the α - particles were not deflected or only a few deflected through small angles. The unexpected result was that a small number of the α - particles were deflected through considerable large angles of more than 90° , and a few of the α - particles were even deflected back through nearly 180° .

To explain these observations, Rutherford postulated an atomic model. The nucleus carries all the positive charge of atom and nearly all its mass, as a large number of α - particles passing through the foil undeflected suggest that there exist large empty spaces in an atom and those positively charged α - particles that deflected through large angles had come very close to the positively charged nucleus. However, a few were repelled so strongly that they bounced back or deflected through large angles, as shown in figures 19.3 and 19.4.

Self-Assessment Questions:

Q1: What the center of an atom is called?

Q2: Where are the electrons found inside an atom?

19.2 PROTONS, NEUTRONS

The composition of the atom

We studied in previous classes that atoms consist of three elemental particles: electrons, protons, and neutrons. The outermost region of the nucleus is called electron shell. It contains electrons. Electrons have a negative (-) charge. The nucleus contains the neutrons and the protons bound tightly together by the nuclear forces (gluons) as shown in figure 19.5. Neutrons carries no charge. The mass of a neutron is slightly larger than that of a proton. Proton have an equal positive (+) charge that of an electron in magnitude. An atom usually has an equal number of protons as electrons, so its net charge is zero. Therefore atom is



considered neutral. Atoms have different properties depending upon the arrangement and number of their elemental particles;

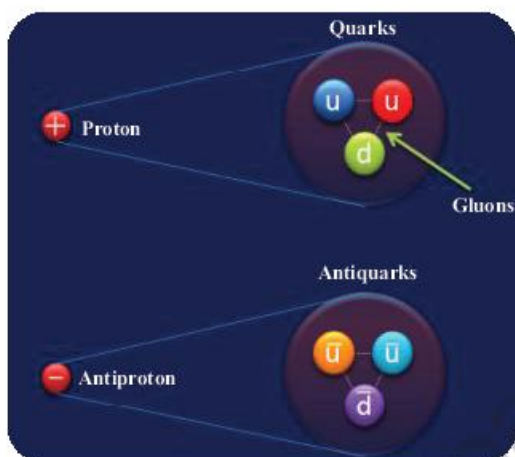

Fig: 19.5

The strong force binds quarks together in clusters to make more-familiar subatomic particles, such as protons and neutrons. It also holds together the atomic nucleus and underlies interactions between all particles containing quarks.

Table 19.1

The relative masses and charges of particles in an atom

Name of Particle	Relative Mass	Relative Charge
Proton	1	+1
Neutron	1	0
Electron	1/1836	-1

The branch of physics concerned with the study and understanding of the atomic nucleus, including its composition and the forces which bind it together, is called nuclear physics.

Self Assessment Questions:

Q1: An atom consists of electrons revolving around the nucleus made of neutrons and protons. State which of these particles have

- (i) An equal and opposite charge
- (ii) Almost equal mass.



Fig: 19.6
A model of the atomic nucleus showing it as a compact bundle of the two types of particles: protons (red) and neutrons (blue)



Weblinks

Encourage students to visit below link for Atom and its composition
https://www.youtube.com/watch?v=pNroKeV2fgk&ab_channel=FuseSchool-GlobalEducation

**Do You Know!**

Only electron is fundamental particle

**Do You Know!**

If the atom is the size of a football ground, the nucleus would be the size of a pea. Although the nucleus is much denser than the rest of the atom.

**Weblinks**

Encourage students to visit below link for Atomic Number

https://www.youtube.com/watch?v=D3GR6htApI&ab_channel=Don%27tMemorise

19.3 ELEMENTS

All materials are made from about 100 essential substances known as elements. The smallest part of an element is an atom. How is it possible to find the characteristics that differ between each element and distinguish one element from another? Each element has a unique number of protons.

The number of protons in the nucleus of an atom in an element is called atomic number (Z).

The atomic number distinguishes one element from another. For example, the atomic number (Z) of carbon is six because it has 6 protons, and the atomic number (Z) of nitrogen is seven because it has 7 protons. There are some other examples given in table 19.2. The atomic number also tells you the number of electrons in that atom.

Table 19.2.
Atoms of the first eight elements of the periodic table

Name of Element	Protons $P = Z$	Neutrons $N = A - Z$	Electrons e^-	Atomic Number $Z = P^+$	Atomic Mass (A)
Hydrogen	1	0	1	1	1
Helium	2	2	2	2	4
Lithium	3	4	3	3	7
Beryllium	4	5	4	4	9
Boron	5	6	5	5	11
Carbon	6	6	6	6	12
Nitrogen	7	7	7	7	14
Oxygen	8	8	8	8	16

Nuclides

An atom of an element has all the characteristics of that element. The nucleus is at the center of the atom and contains the protons and neutrons, which are collectively called nucleons. The number of protons in an atom of an element is called the atomic number, (Z). The number of neutrons in the nucleus is the neutron number, (N).

The number of protons and neutrons is collectively known as nucleon number (A) or atomic mass (A).

The total number of nucleons is the atomic mass, **A**.
Table 19.2. These numbers are related by the symbol **A**.

$$A = Z + N$$

A nucleus is represented symbolically by:



Where **X** represents the nuclide of a chemical element, **A** is the nucleon number, and **Z** is the atomic number.

For example, ${}_6 C^{12}$ represents the carbon nucleus with six protons and twelve nucleons. Thus, the total orbiting electrons are also six, and the neutron number is:

$$A = Z + N$$

$$N = A - Z$$

$$N = 12 - 6$$

$$N = 6$$

Self-Assessment Questions:

Q1: The nuclide notation for the uranium-235 is ${}_{92} U^{235}$. Determine the proton number, electron number, neutron number, and nucleon number of the uranium.

19.4 ELEMENTS AND ISOTOPES

Isotopes

The atoms of an element are not exactly alike. Some may have more neutrons than others. These different variants of the elements are called isotopes.

Two or more species of atoms of an element with the same atomic number, (**Z**) have different atomic mass, (**A**) is called Isotopes.

Most elements have mixture of two or more isotopes. For example, the hydrogen atom (atomic number 1) has three isotopes with atomic masses 1, 2, and 3. You can see how to represent an atom of Hydrogen using symbols and numbers in the table 19.3 given below.

Table 19.3. Isotopes of the Hydrogen atom

Name of Isotope	Proton number, Z	Neutron Number, N	Atomic Mass, A	Symbol
Protium	1	0	1	${}_1 H^1$
Deuterium	1	1	2	${}_1 H^2$
Tritium	1	2	3	${}_1 H^3$

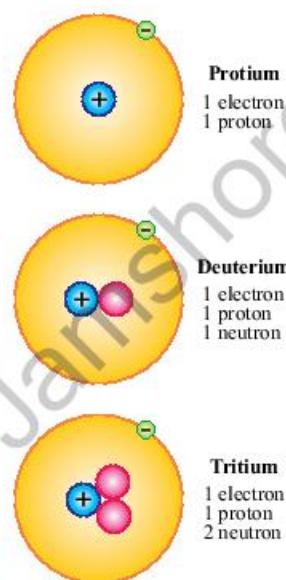

Fig: 19.7.
Isotopes of hydrogen

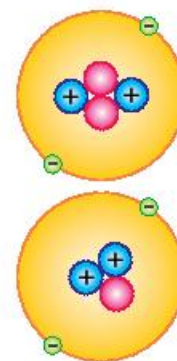

Fig: 19.8.
Isotopes of helium



Do You Know!

The elements with the most isotopes are Cesium and Xenon with 36 known isotopes.



Do You Know!

The term isotope is formed from the Greek roots isos "equal" and topos "place", meaning "the same place"; thus, the meaning behind the name is that different isotopes of a single element occupy the same position on the periodic table.

Every element has a specific position in the periodic table and nearly identical chemical behavior or properties with the same number of electrons.

Many other essential properties of an isotope depend on its mass. The total number of neutrons and protons in the nucleus of mass number (symbol A) gives it different physical properties, i.e. mass, surface area, volume, and density.

Isotopes are two or more species of atoms of an element with identical chemical properties that have different physical properties.



 **CONCEPT MAP**

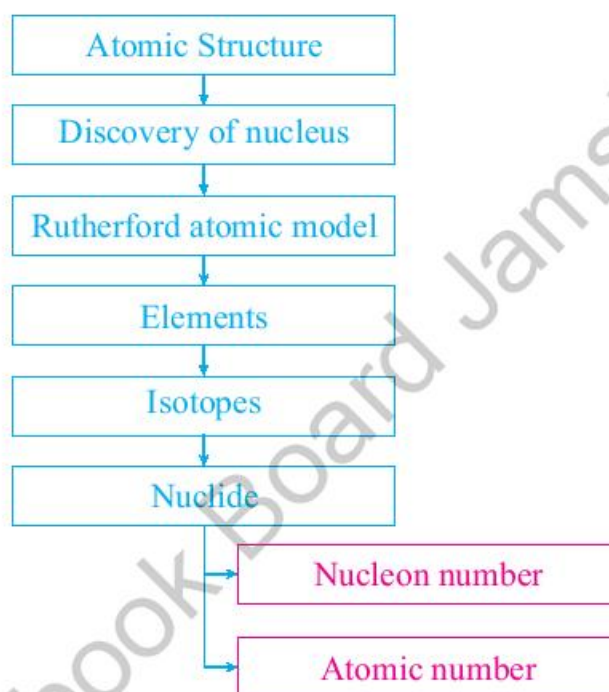

Sindh Textbook Board Jamshoro



SUMMARY

- Everything around us is made up of atoms.
- Atom is the smallest unit of matter.
- Every atom is composed of two parts; the nucleus and the shell.
- The nucleus is a central small and dense part of the atom that contains protons and neutrons.
- The shell part of the atom contains electrons that orbit at high speed around the nucleus.
- Most of the atom is an empty space.
- In an atom, electric forces bind the electrons to the nucleus.
- An atom consists of three elemental particles: electrons, protons, and neutrons.
- Each element, however, does have a unique number of protons in its nucleus.
- The number of protons in an atom of an element is called the atomic number.
- The number of protons and neutrons in an atom is known as nucleons.
- The total number of nucleons in an atom is called the mass number.
- Isotope has the same atomic number but a different mass number.

Section (A) Multiple Choice Questions (MCQs)

Choose the correct answer from the following choices:

1. ${}^2_1\text{H}$ and ${}^3_1\text{H}$ are:
 - a) Isotopes
 - b) Isobars
 - c) Isotones
 - d) Isochores
2. The neutral atoms of all of the isotopes of the same element have
 - a) different numbers of protons.
 - b) exact numbers of neutrons.
 - c) An exact number of protons.
 - d) An exact number of nucleons.
3. Consider the species ${}_{17}\text{Cl}^{35}$, and ${}_{17}\text{Cl}^{37}$. These species have:
 - a) the exact number of nucleons
 - b) the exact number of protons
 - c) the exact number of neutrons.
 - d) the exact mass number.
4. Atomic mass of an element is equal to
 - a) Mass of protons and neutrons
 - b) Mass of protons and electrons
 - c) Mass of electrons and neutrons
 - d) Mass of protons only



5. The maximum mass of an atom is concentrated in:
- a) nucleus b) neutrons
c) protons d) electrons
6. Consider isotope ${}_{92}\text{U}^{237}$ of uranium. The number of neutrons in it is:
- a) 92 b) 237
c) 145 d) 329
7. The symbol denotes the proton number is:
- a) P b) A
c) N d) Z
8. The number of neutron(s) in Protium is:
- a) no b) one
c) two d) three
9. In an atom, the nucleus when compared to the extra-nuclear part, is
- a) More significant in volume and heavier in mass
b) smaller in volume but heavier in mass
c) More significant in volume but lighter in mass
d) Smaller in volume and lighter in mass
10. If an element B has five protons and six neutrons what will be the symbol of element B
- a) ${}_{11}_6\text{B}$ b) ${}_{11}\text{B}$
c) ${}_{11}_5\text{B}$ d) ${}^5_{11}\text{B}$

Section (B) Structured Questions

1. (a) Which particles are found in the nucleus of an atom?
(b) Describe the structure of an atom.
(c) How does the number of protons in a nucleus distinguish one element from the other?
2. (a) Cite the Geiger Marsden experiment with the help of a diagram.
(b) Give the Rutherford model of an atom.
(c) Why it was proposed that most atoms possess an empty space.
3. (a) Define Atomic number (Z)
(b) Explain the symbolic representation of an atom of an element. Give an example.
4. (a) What is the isotope?
(b) Explain the isotope with an example.
(c) Why are the chemical properties of an element's different isotopes identical?
(d) List the physical properties of different isotopes of an element that are different.

Unit - 20

Nuclear Structure

Students' Learning Outcomes (SLOs)

After learning this unit, students should be able to

- Explain that some nuclei are unstable, give out radiation to eliminate excess energy, and are said to be radioactive.
- Describe that the three types of radiation are α , β & γ .
- State radioactive emissions and their:
 - nature
 - relative ionizing effects.
 - relative penetrating abilities
- Explain that an element may change into another element when radioactivity occurs.
- Represent changes in the composition of the nucleus by symbolic equation when alpha or beta particles are emitted.
- Describe sources of background radiations and artificial radiations.
- Describe that radioactive emissions occur randomly over space and time.
- Explain the meaning of the half-life of radioactive material.
- Make calculations based on the half-life, which might involve information in tables or shown by decay curves.
- Determine the half-life of a sample of radioactive material by using a graph of the number of radioactive nuclei of activity versus time.
- Estimate the age of ancient objects by the process of carbon dating.
- Describe what radio-isotopes are. What makes them useful for various applications?
- Describe the application of radioisotopes in medicine, agriculture, and industrial fields.
- Describe the process of fission and fusion briefly.
- Describe how radioactive materials are handled, used, stored, and disposed of safely.

Nuclear Power Plant K-2 & K-3 Karachi Nuclear Power Project Unit-2 (K-2) & Unit-3 (K-3) in the vicinity of KANUPP, construction work on two nuclear power reactors i.e., K-2 and K-3, was started in August, 2015 and in May, 2016 respectively. These units are based upon Chinese ACP1000 design, that is a Generation-III version of the PWR nuclear reactor technology. In this design, apart from other features, safety is significantly enhanced by using passive safety systems (no need of human action or input power for operation). On 23rd March of the year 2021, K-2 was connected to the national grid and successfully started commercial operation on 21 May, 2021. K-3 also achieved the milestone of grid connection on 4th March, 2022 and its commercial operation is expected very soon i.e., in a few weeks.



The nuclear structure is the area of physics that studies the nuclei of atoms. It is about far more than just nuclear power. Nuclear scientists are studying everything from the shapes of nuclei to cancer treatments and medical imaging, from highly unstable nuclei that only exist for fractions of a second to nuclear detectors. However, upon understanding the nuclear structure and nuclear radiation, we will appreciate that this radiation has peaceful and beneficial applications to our daily lives. Let us study this all in this unit in detail.

20.1 NATURAL RADIOACTIVITY

Atomic nuclei consist of protons and neutrons, whereby protons repel each other through electrostatic force due to their positive charges. In contrast, nuclei bind the nucleons through another specific binding energy. These two forces compete with each other, leading to various nuclei stability. There are only certain neutron-proton pairings that form stable nuclei. As a result, an increasing ratio of neutrons to protons is required to form a stable nucleus. Some proportions of neutrons to protons are more stable than others in a nucleus if the neutron number, N , is plotted against the proton number, Z ; figure 20.1, for all different isotopes of all the elements.



Do You Know!

Binding energy is amount of energy required to separate a particle from a system of particles or to disperse all the particles of the system.



Do You Know!

Higgs Bosons (force carrier)

It is a type of boson which carries mass as well and known as god particle.

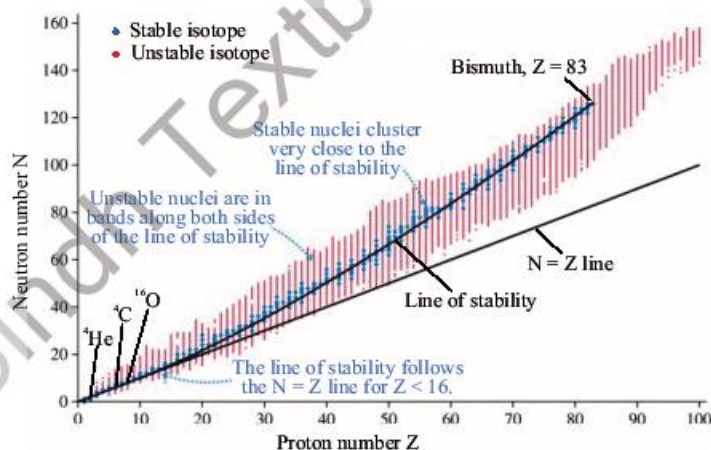

Fig: 20.1. Nuclear stability curve of all isotopes

There are too many or few neutrons for a given number of protons. In that case, the resulting nucleus is unstable, and it undergoes radioactive decay to get rid of excess energy.



Do You Know!

Gluon

It is a type of boson (force carrier) is an exchanging particle of strong nuclear force

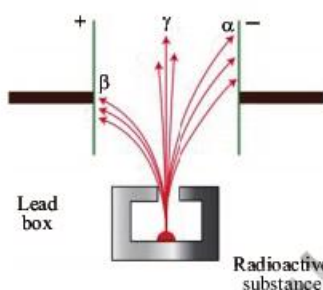

Fig: 20.2
Three types of radiations can be distinguished from their path followed in an external electric field



Do You Know!

The α and β -radiations are affected by a magnetic force that acts if they pass through opposite poles of a magnet.

If an isotope undergoes radioactive decay is called radio-isotope or radioactive element.

The emission of α , β and γ radiation with the release of energy is known as radioactivity.

Types of radiation α , β & γ

To explain the graph of unstable nuclei with the varying number of neutrons as discussed above. It has these salient features as given below.

- i. Stable isotopes lie along with the stability line.
- ii. Isotopes above the stability line have too many neutrons to be stable. The decay for β^- (electron) emission reduces the number of neutrons.
- iii. Isotopes below the line of stability have few neutrons to be stable. The decay for β^+ (positron) emissions increases the number of neutrons
- iv. The heaviest isotopes (proton number, $Z > 83$) decay by α emissions.

Many other infrequent types of decay, such as spontaneous fission or neutron emission, are also observed.

Nature of radioactive emission

To describe the nature of three types of radiation α , β , and γ , the radioactive source is placed inside the electric field. The radiation emitted from the source breaks down into three components: α and β -radiations bend in the opposite direction in the electric field, while γ -radiation does not change its direction; Figure 20.2.

This result describes that.

- α deflected towards a negatively charged while the plate is positively charged,
- β deflected towards a positive plate that is negatively charged. It is deflected more in the field, thus, much lighter than α particles.
- γ rays are not deflected by the field and carry no electric charge.

Further, it was found by further explorations that an alpha particle is a helium nucleus comprising two protons and two neutrons with a charge of $+2e$. Beta radiation is a streamlet of high-energy electrons. Gamma radiations are photons that are electromagnetic radiations of ultra-high frequency.



Relative ionizing effects of radioactive emission

Ions are charged atoms or charged molecules.

Atoms become ions when they lose or gain electrons. Nuclear radiations, i.e., alpha, beta, and gamma, can knock out electrons from atoms in their paths, resulting in an ionizing effect. However, alpha particles have the most significant ionization power than beta particles and gamma rays. It is due to the large positive charge and large mass of alpha particles. Beta particles ionize a gas much less than alpha particles. The ionization power of gamma rays is even less than that of beta particles. The ionization of alpha particles in a gas is given in figure 20.3.

The phenomenon by which radiations split matter into positive and negative ions is called ionization.

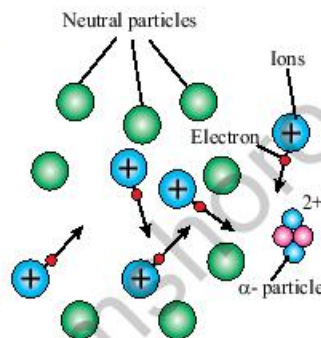

Fig: 20.3.
Ionization of alpha particles in a gas

Relative penetrating abilities of radioactive emission

An alpha particle has the shortest penetrating ability because of its strong interacting or ionizing power. Alpha particle has a penetrating range of only a few centimeters in the air; they can be stopped by a thick sheet of paper or by the skin. The beta radiation interacts with the matter due to its charge and has a high penetrating range compared to alpha particles. Beta particles have a range of several meters in the air. They can penetrate through thick paper but are stopped by a few millimeters of aluminum. However, gamma rays range several hundreds of meters in the air. The gamma rays are very penetrating, never completely stopped through lead, and thick concrete will reduce their intensity. It is due to their high speed and neutral nature. Fig. 20.4 shows the relative penetrating abilities of three kinds of radiations.

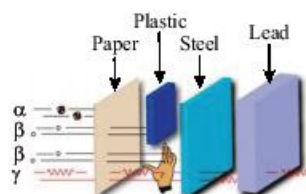

Fig: 20.4.
Relative penetrating abilities of three kinds of radiations.

The strength of radiations to penetrate a certain material is called penetrating power.

Self Assessment Questions:

- Q1:** Which force is responsible for binding protons in the nucleus?
Q2: What is the nature of alpha radiations?
Q3: Define the penetrating power?



Do You Know!

In the core of the Sun hydrogen is being converted into helium. This is called nuclear fusion. It takes four hydrogen atoms to fuse into each helium atom. During the process some of the mass is converted into energy

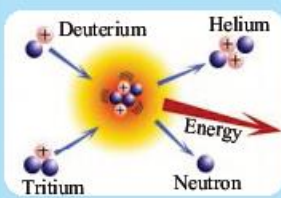

Q4: Why do gamma radiations have a high penetrating ability?

Q5: Iron-59 emits beta and gamma radiations simultaneously. Explain how the gamma radiation could be separated from beta radiations emitted?

20.2 NUCLEAR TRANSMUTATIONS

We know that if an isotope is radioactive, it has an unstable arrangement of neutrons and protons. The emission of alpha or beta particles makes the nucleus more stable, whereas it changes the number of protons and neutrons. So it transmutes to the nucleus of a different element.

The original nucleus before decay is called the **parent nucleus**.

The nucleus formed after decay is called the **daughter nucleus**.

Radioactive disintegration causes nuclear transmutation and converts one chemical element or isotope into another chemical element or isotope.

Now we can represent changes in the composition of the nucleus using a nuclear equation in which an unstable parent nuclide X decays into a daughter nuclide Y by the emission of alpha, beta, and gamma decay products with the release of energy.

Alpha (α)-decay

In alpha decay, the proton number or atomic number, Z of the parent nuclide reduces by 2, while its atomic mass or nucleon number, A, decreases by 4.

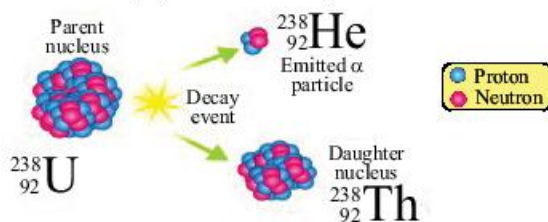

Do You Know!

Helium nuclei is also known as α .

Its general equation

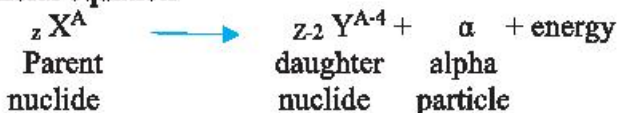



Example:

When radium ${}_{88}\text{Ra}^{226}$ decays by alpha emission. The alpha decay leaves the nucleus with 2 protons and two neutrons less than before. So the atomic number drops to 86 and the atomic mass to 222. Radon has the atomic number of 86, so radon is the new element formed. Its decay process can be written as,



Beta (β)-decay

In beta decay, the atomic number Z of the parent nuclide increases by one, and its atomic mass or nucleon number remains unchanged.

Its general equation is

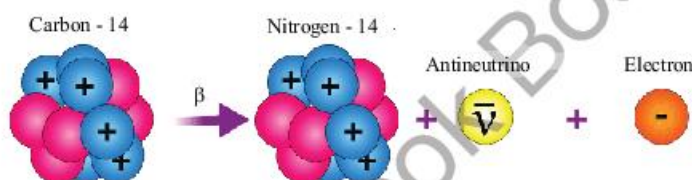
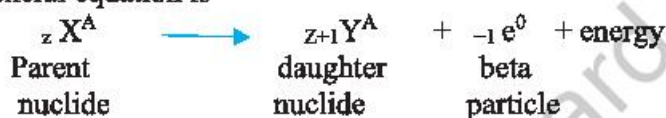

Beta-minus Decay

Example:

When carbon ${}_{6}\text{C}^{14}$ decays by beta emission. The beta decay leaves the nucleus with one more proton and one neutron less than before. So the atomic number increases to 7, and the mass number remains unchanged. Nitrogen has the atomic number of 7, so nitrogen is the new element formed. Its decay process can be written as,

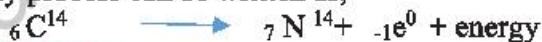

Beta (β)+ decay

In positron emission/positive beta decay (β^+ -decay), A proton in the parent nucleus decays into a neutron that remains in the daughter nucleus and the nucleus emits a neutrino and a positron, which is a positive particle like an ordinary electron in mass but of opposite charge.



Weblinks

Encourage students to visit below link for Radioactivity:
Expect the unexpected

https://www.youtube.com/watch?v=TJgc28csgV0&ab_channel=TED-Ed



Weblinks

Encourage students to visit below link for Alpha and Beta decay

https://www.youtube.com/watch?v=UtZw9jflxXM&ab_channel=FuseSchool-GlobalEducation

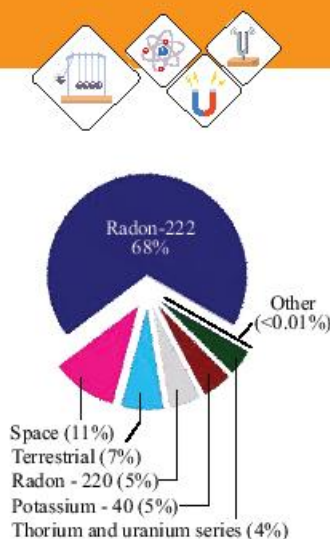

Fig: 20.5.

Sources of background radiations



Do You Know!

When cosmic rays enter the atmosphere, they undergo various transmutations, including the production of neutrons. When nitrogen-14 atoms absorb these thermal neutrons, radio-carbon-14 is produced in the upper layers of the atmosphere.

$${}_{0}n^{1} + {}_{7}N^{14} \rightarrow {}_{6}C^{14} + {}_{1}p^{1}$$

Fig: 20.6.
Shower of radiation



Self-Assessment Questions:

- Q1:** Define Nuclear Transmutation.
Q2: What nuclear changes take place in gamma emission?
Q3: When a nuclide of Strontium-90 (${}_{38}\text{Sr}^{90}$) decays by the emission of β particle, it becomes the nucleus of the Yttrium; symbol Y. Complete the nuclear equation.

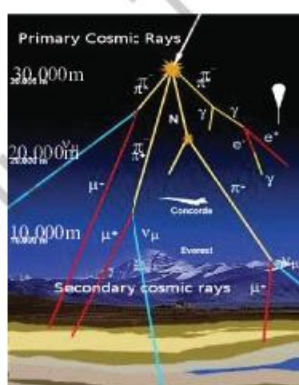
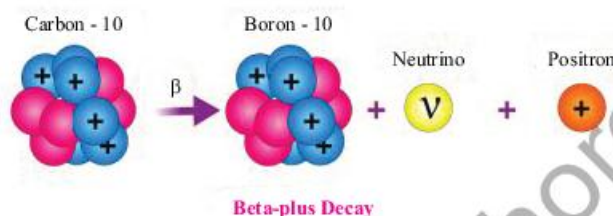
20.3 BACKGROUND RADIATION

We are surrounded by the atmosphere on the surface of the Earth. There are a small number of radiations around us due to the radioactive elements present in the surroundings. These radiations mainly originate from various natural sources such as soil, rocks, air, building materials, food and drinks, and even from space.

These natural radiations that come from the surroundings are called background radiations.

In some areas, over half of these radiations come from radioactive radon ${}_{86}\text{Rn}^{222}$ gas, rocks seeping, and some types of granite; Figure 20.5.

Our planet Earth is also exposed to radiation from outer space called cosmic radiations, consisting of electrons, protons, alpha particles, and larger nuclei. The cosmic radiation interacts with atoms in the atmosphere to create a shower of radiation; figure 20.6, including X-rays, muons, protons, alpha particles, electrons, and neutrons.

Radioactive emissions occur randomly over space and time

Spontaneous decay is a process in which environmental factors cannot influence.

Radioactive decay takes place naturally (all by itself). There is no way of predicting when a particular nucleus will disintegrate, and the process is unaffected by



pressure, temperature, chemical conditions, and other physical conditions. However, some nuclei undergo nuclear disintegration at different rates.

A random decay is a process in which the exact time of decay of a nucleus cannot be predicted.

A detector like a Geiger-Muller (GM) tube can demonstrate the random nature by observing the count rate of radioactive disintegration. When a GM tube is placed near a radioactive source, the counts are irregular. Each count represents a decay of an unstable nucleus. The variation of count rate over time of a sample radioactive source is plotted on the graph. You can see the fluctuations in count rate against time; figure 20.7 on the graph that provides evidence for the random nature of radioactive decay over space and time. It can be concluded from the experiment that

- The time of each decay cannot be predicted
- The direction in which radiation is emitted is not possible to determine.

20.4. Half-Life

Explain the meaning of the half-life of radioactive material.

The radioactive decay process is random, and the rate of radioactive decay is proportional to the number of unstable nuclei present. In the decay process, a constant fraction of many unstable radioactive nuclei disintegrates at a certain time. The lifespan of the unstable nuclei is indefinite and is challenging to measure. We can think of about decay rate by another term, half-life.

The half-life of a radioactive isotope is the time taken for half of the nuclei present in any given sample to decay.

Iodine-131 is a radioactive isotope of iodine. Iodine-131 has an eight-day half-life, which means that half of an iodine-131 sample will be converted to other elements within 8 days; Fig. 20.8. Half of the remaining iodine will decay in the next eight days, leaving eight only one-fourth

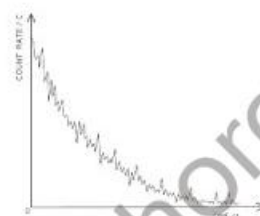

Fig: 20.7.
The fluctuation show the random nature of radioactive decay



Do You Know!

We all receive exposure to man-made radiation, such as X-rays, radiation used to diagnose diseases, and cancer therapy. The fallout from nuclear explosives testing and also small amounts of radioactive materials released to the surroundings from coal and nuclear power plants are also sources of manufactured background radiation.



of the original amount of radium, and so on, the decaying process continues.

Do You Know!

Experts have used scientific dating techniques to verify the historical chronology of ancient Egypt. Radiocarbon dating was used to show that the chronology of Egypt's Old, Middle and New Kingdoms is indeed accurate.

The researchers dated seeds found in pharaohs' tombs, including some from the tomb of the King Tutankhamun.

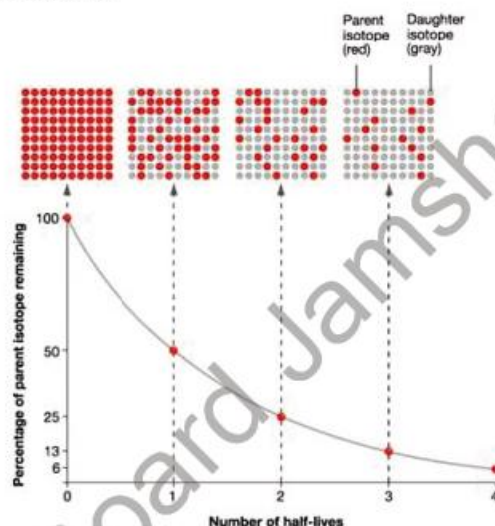

Fig: 20.8 Radioactivity of iodine

Every radioactive element has its characteristic half-life. The half-lives of some radioactive isotopes are given in the table below. It might seem strange that some isotopes have short half-lives while others have long half-lives.

Table 20.1 Half-lives of some radioactive nuclides

Radioactive isotope	Half-life
Boron-12	0.02 seconds
Radon-220	52 seconds
Iodine-128	25 minutes
Radon-222	3.8 days
Iridium-192	74 days
Cobalt-60	5.27 years
Strontium-90	28 years
Radium-226	1602 years
Carbon-14	5730 years
Plutonium-239	24400 years
Uranium-235	7.1×10^8 years
Uranium-238	5×10^9 years



If the radioactive element is $T_{1/2}$, then the number of nuclei in the sample will become half at the end. After a time of $2T_{1/2}$, i.e., after the second half-life period, the number of remaining nuclei will become $1/2 \cdot 1/2 = 1/2^2 = 1/4$; after a time of $3 T_{1/2}$, the number of remaining nuclei left will be $1/2 \cdot 1/2 \cdot 1/2 = 1/2^3 = 1/8$, and at the end of ' n ,' half-lives number of atoms that remain will be $1/2^n$. Thus, using the equation below, we can determine how much of the original amount of sample remains after a certain interval of time,
The remaining amount of sample = $1/2^n \times$ the original amount of the sample

Where n is the number of half-lives.

Worked Example 1

If there are 96 grams of radioactive element Neptunium-240 present, how much Np-240 will remain after 6 hours? (Neptunium-240 has a half-life of 1 hour)

Solution:

Step 1: Write down the known quantities and quantities to be found.

Mass of the sample, $m = 96$ grams

Half-life of the sample, $T_{1/2} = 1$ hour

Time, $t = 6$ hours

Number of half-lives, $n = \text{time interval/half-life}$
 $= 6 \text{ hours} / 1 \text{ hour}$
 $n = 6$

Step 2: Write down the formula and rearrange if necessary
 Remaining mass of the sample = $1/2^n \times$ Mass of the sample

Step 3: Put the values and calculate.

Remaining mass of Neptunium-240 = $1/2^6 \times 96$ grams
 $= 1/64 \times 96$ grams
 $= 1.5$ grams

After 6 hours, only 1.5 grams of the original 96 grams sample would remain in the radioactive isotope of Neptunium -240.



Do You Know!

"Many scholars were not satisfied with these relative dating methods [of the Indus civilization by John Marshall and Sir Mortimer Wheeler from 1930s-50s], which relied on distant Mesopotamian chronologies, but it was not until after the introduction of the radiocarbon dating technique in the 1950s that the situation began to change. During his excavations at Mohen-jodaro in 1964-65, George F. Dales collected the first series of samples for radiocarbon dating from the latest levels of the city.





Weblinks

Encourage students to visit below link for What is Radioactivity and Is It Always Harmful

https://www.youtube.com/watch?v=M0uw4ZNpqcI&ab_channel=ScienceABC



Weblinks

Encourage students to visit below link for Half life of radioactive material

https://www.youtube.com/watch?v=IDkNIU7zKYU&ab_channel=FuseSchool-GlobalEducation

Worked Example 2

A sample of Ac-225 originally contained 8.0×10^{24} nuclei. After 960 hours, how much of the original sample remains un-decayed. The half-life of the isotope is ten days.

Solution:

Step 1: Given data and find unknown

Original number of nuclei, $N = 8.0 \times 10^{24}$ nuclei

Given time, $t = 960$ hours
 $= 960/24$ days
 $= 40$ days

Number of half-lives, $n = \text{time interval} / \text{half life}$
 $= 40 \text{ days} / 10 \text{ days}$
 $n = 4$

Step 2: Write Remaining number of nuclei $= 1/2^n \times$ the original number of nuclei

Step 3: Put the values and calculate.

Remaining number of Ac-225 nuclei $= 1/2^4 \times 8.0 \times 10^{24}$ nuclei
 $= 1/16 \times 8.0 \times 10^{24}$ nuclei
 $= 5.0 \times 10^{23}$ nuclei

After 960 hours, only 5.0×10^{23} nuclei of the original 8.0×10^{24} nuclei sample would remain the radioactive isotope of Ac-225.

Worked Example 3

How long will it take to decay for 36.0 mg of Ra-226 to leave 4.5 mg? The half-life of the isotope is 1600 years.

Solution:

Step 1: Given data and find unknown.

Mass of original sample = 36.0 mg.

Mass of remaining sample = 4.5 mg

The half-life of the sample = 1600 years

Number of half-lives $= 1/2^3 (36 \text{ mg}) = 4.5 \text{ mg}$.

Step 2: Write down the formula and rearrange if necessary

The required time = number of half-lives \times half-life

Step 3: Put the values and calculate.

The required time $= 3 \times 1600$ years
 $= 4800$ years

This decay process requires 4800 years.



Radio activity

To determine the half-life of a sampling of radioactive element for some given data showing how the activity (or the number of nuclei) changes over time: Plot a graph of this data, activity or number of nuclei changes on the y-axis with time on the x-axis. Draw a smooth best fit curve closer to the x-axis.

Now, look at the original activity (where the line crosses the y-axis) and halve it. Move from the halved value (on the y-axis) to the best fit curve, and straight down to the x-axis. The point where you reach the x-axis should be the half-life of the sample radioactive element. Repeat it to take second and third half-lives and get an average to avoid any possible error.

Example:

Iodine-131 is a radioisotope. It undergoes decay by beta particle emission into xenon-131. From the graph, its initial percentage activity is 100%. After eight days have passed, half of the atoms of the sampling of iodine-131 will have decayed, and the sample will now be 50% iodine-131. After the next eight days pass (a total of 16 days or two half-lives), the sample will be 25% iodine-131. This decaying continues until the entire sample of iodine-131 has completely decayed; Fig. 20.9.

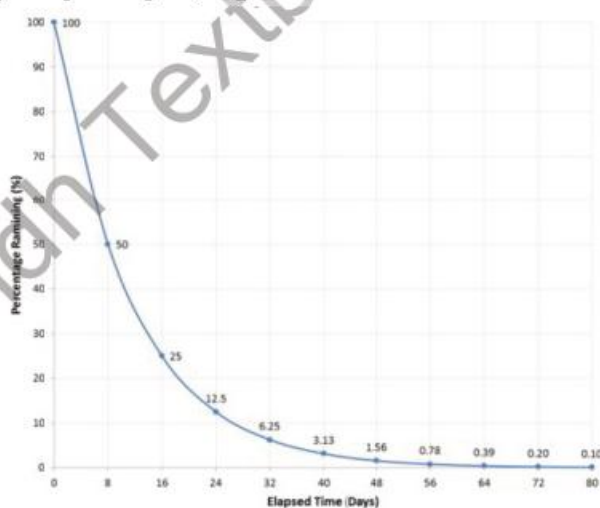

Fig: 20.9. Decay curve of Iodine-131

Do You Know!

Units of Radiation and Radioactivity

Becquerel (Bq)

Unit for intensity of radiation:

One nucleus decay (degenerates) per second
= 1 becquerel

Sievert (Sv)

Unit of radiation exposure does which a person receives:
Associated with radiation effects





Estimate the age of ancient objects by the process of carbon dating.

Radioactive dating is a process by which the approximate age of an object is determined by using certain radioactive nuclides.

For example, radioisotope carbon-14 is found in a small amount in the atmosphere and is used to measure the age of organic material. Living plants and animals use carbon dioxide and become slightly radioactive accordingly. While an organism is alive, the amount of carbon-14 remains constant because fresh carbon-14 enters whenever the organism consumes nutrients; Fig. 20.10.

Do You Know!
Activity in radioactive-decay processes, the number of disintegrations per second, or the number of unstable nuclei that decay per second in a given sampling. Activity is expressed in the International S.I. Units by the Becquerel, **Bq** is exactly equal to one disintegration per second.

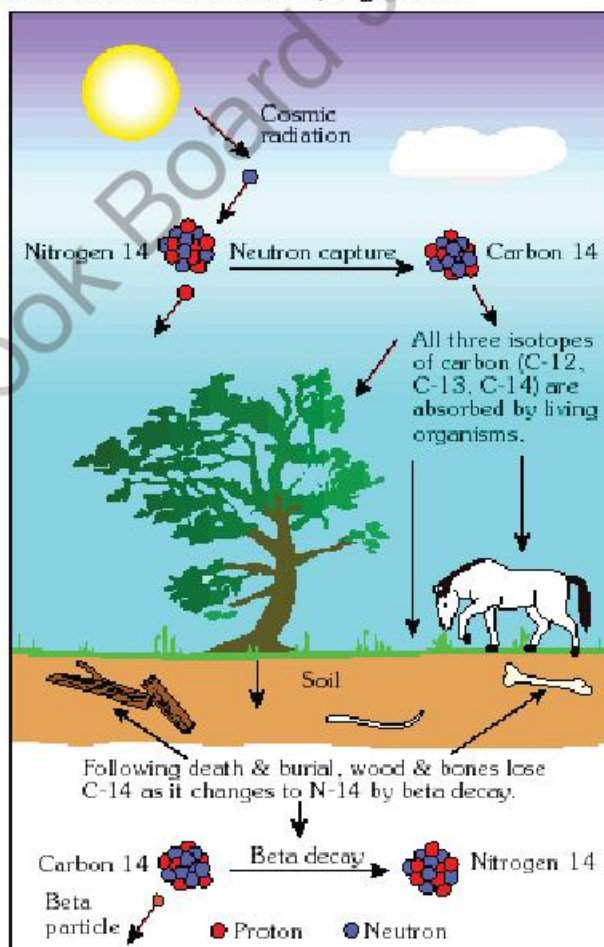

Fig: 20.10 Cycle of Radio Carbon-14



When an animal die, no more carbon is absorbed, and the radio carbon-14 present inside the animal starts decaying to nitrogen-14. Since the half-life of carbon-14 is 5730 years, archeologists can estimate the age of remains by computing the activity of carbon-14 in the live and dead animals.

Self Assessment Questions

- Q1: Can the decay half-life of radioactive material be changed?
Q2: Why the radioisotopes of greater half-lives are used in radioactive dating of archeological relics?

Radio Isotopes 2.05

Radio-isotopes

The radioisotope is also a radioactive isotope, radionuclide, or radioactive nuclide. A radioisotope is a kind of the same element with different masses. It undergoes decay spontaneously and emits radiation to dissipate excess energy.

We have learned that every element has one or more isotopes. For example, hydrogen, the lightest element, has three isotopes H^1 , H^2 and H^3 . Only H^3 (tritium) is unstable. However, it is a radioactive isotope and undergoes nuclear decay.

The stable and non-radioactive elements can also be transmuted into radioactive elements by exposing them to neutrons, or alpha particles. Such artificially produced radioactive elements are also called radioisotopes. Here are some examples of the production of radioisotopes:

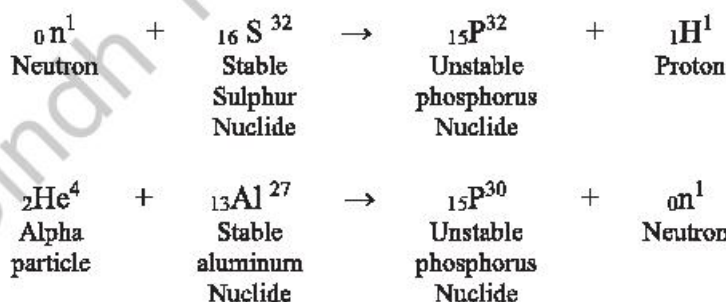

In these examples, P^{32} and P^{30} produced are artificial radioisotopes.



Do You Know!

Radioisotope potassium-40 is used for dating rocks to estimate the age of the geological specimen. The unstable K-40 is trapped when molten material cools to form igneous rock. This K-40 decays to the stable argon nuclide Ar-40 with a half-life of 2.4×10^8 years. The age of the rock sample can be estimated by computing the concentrations of K-40 and Ar-40.



Do You Know!

Uranium-containing minerals that have been analyzed by radioactive dating have allowed scientists to determine that the Earth is over 4.5 billion years old.



Applications of radioisotopes in medicine, agriculture, and industrial fields.

The attributes of naturally and artificially decaying elements, radioisotopes, give rise to their multiple applications across many aspects of modern-day life. Radioisotopes are often used in medicine, industry, and agriculture for various beneficial purposes. Some practical applications of radioisotopes in different fields are given below.

1. Radiotracers

A radioactive tracer is a chemical compound in which a short-lived radioisotope has replaced a few atoms. Tracers monitor the metabolism of chemical reactions inside the human body, animals, or plants. Radioisotopes are used as tracers in medicine, industry, and agriculture.

In medicine, a patient drinks a liquid containing radio iodine-131, a gamma emitter, to check thyroid function. Over the next 24 hours, a detector measures the activity of the tracer to find out how quickly it becomes concentrated in the thyroid gland.

For the diagnosis of brain tumors, the phosphorous-32 isotope is used. The malignant part of the body absorbs more quantity, which helps trace the affected section of the body.

In industry, manufacturers use tracers to monitor flow and filtration to detect leaks in the equipment. A small amount of short-lived radioactive substances is used in various processes and scanned the flow rates of various materials, including liquids, powders, and gases, to locate leakages. Radiotracers are also used in the oil and gas industry to detect and estimate the extent of oil fields.

In agriculture, fertilizer uptake in the plant from root to leaves is traced by adding tracer phosphorus- 32 to the soil water.



Do You Know!

Radiations interact with matter to produce the excitation and ionization of an atom or molecule. As a result, physical and biological effects are produced. These physical and biological effects of radioisotopes produced are widely used in our daily life.

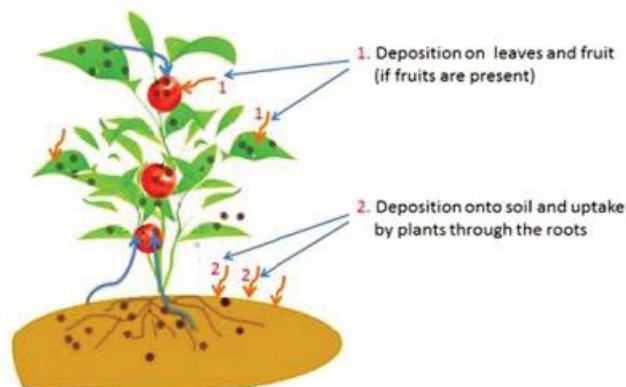

Fig: 20.11 Illustration of radionuclide transfer to plants

2. Medical treatment

In nuclear medicines, radioisotopes are used for curing various diseases. For example, cobalt-60 is a strong gamma emitter. These rays can penetrate in-depth into the body and kill the malignant tumor cells in the patient. Treatment like this is called radiosurgery.

3. Testing for cracks

Gamma rays have high penetrating power, so they can photograph metals to check cracks. A cobalt-60 is a natural gamma rays source and does not need electrical power like an x-ray tube.

Self-Assessment Questions

- Q1: What is the main difference between stable and unstable nucleotides?
- Q2: Why specific radioactive tracers are used orally in medical imaging?
- Q3: Why are the radioisotopes of shorter half-lives used in nuclear medicine?

20.6. Fission and Fusion

Nuclear reactions are processes in which one or more nuclides are produced from the collisions between two atomic nuclei. The nuclides produced from nuclear reactions are different from the interacting nuclei or parent nuclei. Two notable nuclear reactions are **nuclear fission reactions** and **nuclear fusion reactions**. Let us learn about these nuclear reactions.

Do You Know!

Gamma Knife radiosurgery is a radiation therapy used to treat tumors, malformations, and other abnormalities in the brain. Gamma Knife radiosurgery uses equipment to focus about 200 tiny radiation beams on a tumor. Each beam has a minimal effect it passes through. A strong dose of radiation is given to the tumor. This stereotyped radiosurgery minimizes radiation risk to the target's healthy tissues.

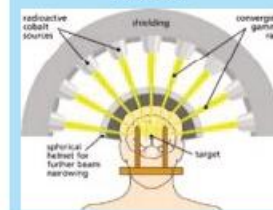



Do You Know!

In nuclear fission, the total mass of the products is less than the original mass of the heavy nucleus that is converted into energy.



Do You Know!

The fission of enriched uranium, U-235 of 1 Kg, can produce as much energy as 55 tons of burning coal.

Nuclear Fission

Nuclear fission occurs when a heavy nucleus, such as U-235 absorbing a slow-moving neutron, splits or fissions into two smaller nuclei with the release of energy.

For example:

When U-235 captures a neutron, an intermediate, highly unstable nucleus, U-236 is formed that disintegrates only for a fraction of a second into two smaller nuclei of nearly equal fragments, Kr-144 and Barium-89, called **fission fragments** accompanied by two or three neutrons.

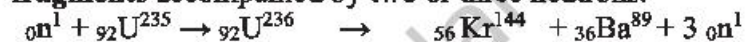

Measurements showed that about 200 MeV of energy is released in each fission event.

The schematic illustration; Fig. 20.12 represents the fission of ${}_{92}^{235}\text{U}$.

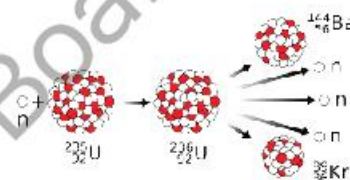

Fig: 20.12. Schematic illustration of nuclear fission

Chain Reaction:

In each nuclear fission, a few neutrons are emitted. These neutrons can, in turn, trigger further nuclei to undergo fission with the possibility of a chain reaction; Fig.20.13. Computations show that if the chain reaction is not controlled, it will explode, releasing massive energy.

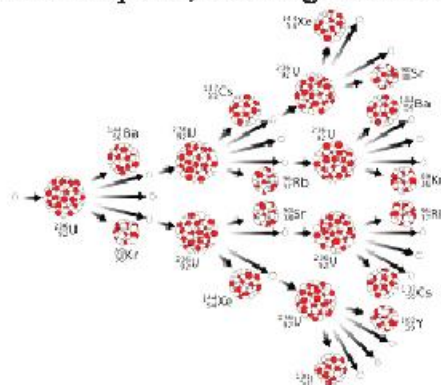

Fig: 20.13. The fission chain reaction in U-235



This fission chain reaction is controlled in nuclear reactors. A nuclear reactor provides an enormous amount of energy for our valuable purposes.

Nuclear Fusion

Nuclear fusion occurs when two light nuclei combine to form a heavier nucleus with the release of energy.

For example: When a nucleus of Deuterium (H^2) is fused with a nucleus of Tritium (H^3), then a Helium nucleus or alpha particle is formed as represented by the equation,

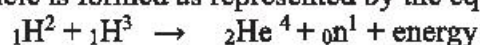

A schematic illustration of the fusion reaction is shown in figure 20.14.

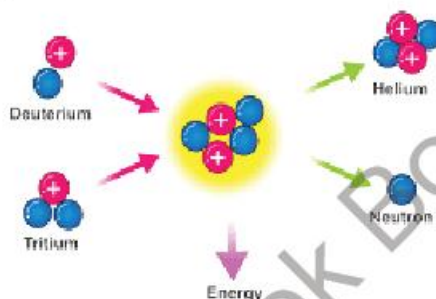

Fig: 20.14. Schematic illustration of nuclear fusion

The total mass of the final nuclei is always less than the mass of the original nuclei. This loss of mass produces nuclear energy.

Self-Assessment Questions

Q1: What is meant by

- a) Nuclear fission
- b) Nuclear chain reaction
- c) Nuclear fusion

Q2: Give an example of

- a) Controlled chain reaction
- b) Uncontrolled chain reaction

20.7 Hazards and safety measures

Describe how radioactive materials are handled, used, stored, and disposed of safely.

Radiation Hazards

All kinds of ionizing radiations such as α , β , γ , and X-rays can damage body cells when exposed to these radiations greater than the average level.



Do You Know!

Every star in the universe, including the sun, is alive due to the nuclear fusion of hydrogen nuclei into the helium nucleus. The stars use fusion to produce enormous heat and light energy.



Do You Know!

The International Atomic Energy Agency (IAEA) announced the ionizing radiation warning symbol. This symbol, to be used on sealed radiation sources, is aimed to alert anyone, anywhere, to the danger of a vital source of ionizing radiation.



Do You Know!

A radiation dosimeter is a scientific device that detects and measures dose uptake of external high energy ionizing beta, gamma, or X-ray radiation. This badge is labelled by the people working with the radioactive materials being monitored, and it also records the radiation dose received.



The danger from α particles because of their lower penetration power is minimal. If sources of α particles are lodged into the body, through the air, or we eat, it can damage our body tissues.

The β particles are more penetrating and can damage the body surface tissues. Sources of these particles that enter the body can be quite damaging.

The γ rays are highly penetrating and the most dangerous of all other radioactive radiations.

The prolonged exposure to radioactive radiation can produce deep-seated burns, damage to cells or tissues, and the mutations of the cells that can lead to genetic changes. Radioactive exposure can also cause cancerous growth in specific body tissues.

Safety Measures

While working in the radiology department in hospitals, nuclear reactors, and research laboratories, should take the following safety measures to avoid any risk of radiation hazards:

- i. Keep all radioactive sources at a safe distance from the body.
- ii. Minimize the time spent near radioactive materials.
- iii. Wear personal protective equipment, including a laboratory coat, gloves, safety glasses, and close-toed shoes.
- iv. Lapel the dosimeter badge always and monitor regularly.
- v. Do not eat, drink, smoke or touch exposed areas of skin while working in a room where radioisotopes are handled.
- vi. Use tongs to handle radioactive sources.
- vii. After use, must return the source immediately to its lead boxes.
- viii. All radioactive sources should be kept in thick lead containers.
- ix. Dispose of all radioactive waste under permitted regulation or statutory control.



SUMMARY

- Atomic nucleus consists of protons and neutrons.
- Radio-isotope, an isotope that undergoes radioactive decay.
- Radioactivity is the emission of radioactive radiation elements with the release of energy.
- The α and β –radiations are affected by an electric field and a magnetic field.
- Ionization is a phenomenon by which radiations split matter into positive and negative ions.
- The alpha particle has the shortest penetrating ability.
- The gamma rays are very penetrating, stopped through lead and thick concrete.
- Penetrating power is the strength of radiations to penetrate a specific material.
- Nuclear transmutation is converting one chemical element into another element.
- In alpha decay, the proton number of the parent nuclide reduces by 2, and its atomic mass decreases by 4.
- In beta decay, the proton number of the parent nuclide increases by 1, and its atomic mass remains unchanged.
- Background radiations are natural radiations that come from the surroundings.
- Spontaneous decay is a process that environmental factors cannot influence.
- A random decay is a process in which the exact time of decay of a nucleus cannot be predicted.
- The half-life of a radioactive element is the time taken for half of the nuclei present in any given sample to decay.
 - Radioactive dating is when an object's approximate age is determined using radioactive nuclides.
- Radioactive tracers monitor the metabolism of chemical reactions inside living objects.
- Nuclear fission is a process in which a heavy nucleus absorbs a slow neutron splits into two smaller nuclei with the release of energy
- Nuclear fusion is a process in which two light nuclei combine to form a heavier nucleus with the release of energy.



CONCEPT MAP

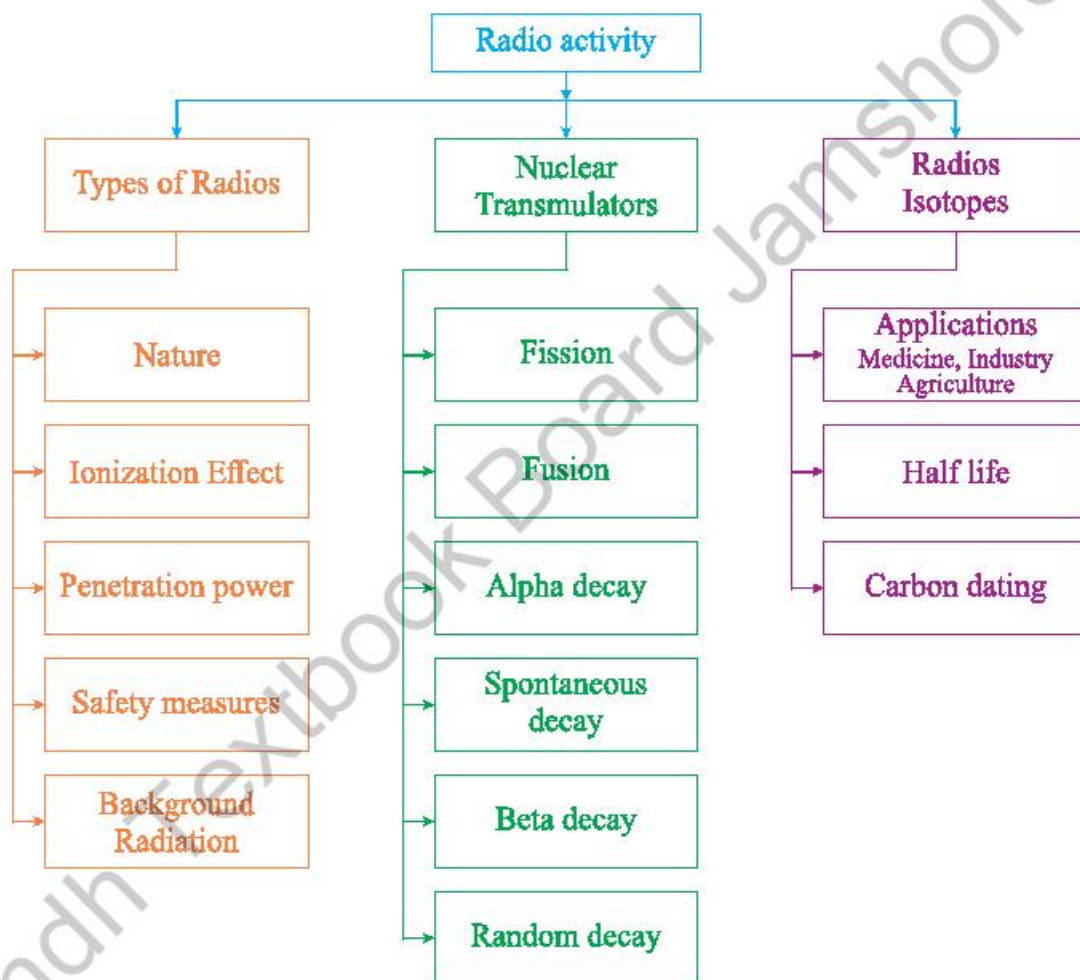



Section (A) Multiple Choice Questions (MCQs)

Choose the correct answer from the following choices:

- The α -radiation is
 - A stream of fast-moving electrons.
 - A form of electromagnetic radiation.
 - Highly ionizing than γ -radiation.
 - More penetrating than β -radiation.
- A radioactive nuclide emits a β -particle. The atomic number (proton number) of the nucleus
 - Stays the same.
 - Increases by 1.
 - Decreases by 2.
 - Decreases by 4.
- A radioactive element emits a particle from the nucleus of one of its atoms. The particle comprises two protons and two neutrons. The name of this process is called
 - α -emission
 - β -emission
 - γ -emission
 - Nuclear fission
- A radioactive decay can be represented as shown. ${}_{91}\text{Pa}^{233} \rightarrow {}_{92}\text{U}^{233} + \dots$
The emitted particle is a/an
 - Gamma-ray.
 - Proton.
 - α -particle.
 - β -particle.
- The type of radiation that travels in a straight line across an electric field is a/an
 - Proton
 - Electron
 - Alpha particle
 - Gamma-ray
- A powder contains 100mg of a radioactive material that emits α -particles. The half-life of the isotope is five days. The mass of isotope that remains after ten days will be
 - 0mg
 - 25mg
 - 50mg
 - 75mg
- The main source of energy in the stars is.
 - Chemical reaction
 - Nuclear fission
 - Nuclear fusion
 - Mechanical energy
- The splitting of a heavy nucleus into smaller nuclei is called
 - Fusion
 - Fission
 - Half-life
 - Gamma decay
- A process in which two light nuclei combine to form a heavier nucleus is called
 - Nuclear fusion
 - Nuclear fission
 - Beta-decay
 - Alpha-decay



10. Which row shows the nature and the penetrating ability of β -particles?

	Nature	Most are stopped by
a)	helium nucleus	a few mm of aluminum
b)	helium nucleus	a thin sheet of paper
c)	electron	a few mm of aluminum
d)	electron	a thin sheet of paper

11. Compared with α -particles and β -particles, γ -rays,
- Are a type of radiation to carry a charge.
 - Have the most significant ionizing effect.
 - Have the most significant penetrating effect.
 - Have the most negligible mass.
12. The severe health hazards caused by radioactive emissions is/are.
- Cancer
 - Genetic change
 - Deep-seated burns
 - All of these
13. Radioactive materials should be handled carefully. Which safety measure does not reduce the risk of using radioactive material?
- Keeping the material a long distance
 - Keeping the material at a low temperature
 - Using lead screening
 - Using the material for a short time
14. A scientist experiments using a sealed source that emits β -particles. The range of the β -particles in the air is about 30cm. The precaution that is the most effective to protect the scientist from the radiation is,
- Handling the source with long tongs
 - Keeping the temperature of the source low
 - Opening all windows in the laboratory
 - Washing his hands before leaving the laboratory
15. The safest way to dispose of a large quantity of radioactive waste is,
- Burying it in a dry rock deep underground
 - Washing it in the drain
 - Burning it on a fire
 - Draining it into the sea

Section (B) Structured Questions

- Define the term radioactivity.
 - What do you mean by the term stable nucleus?
 - Why are some elements radioactive, but some are not?



2. The uranium isotope ${}_{92}\text{U}^{238}$ with atomic mass (nucleon number) 238 and atomic number 92.
- State the nucleon number.
 - Uranium-238 nuclide decays to form a thorium nuclide (symbol Th) by emission of an alpha particle. State
 - The proton number of an alpha particle,
 - The nucleon number of an alpha particle,
 - The proton number of thorium
 - The nucleon number of thorium isotopes formed.
 - Complete the nuclear equation of the uranium decay
3. A radioactive rock emits gamma rays. A demonstrator plans to experiment to show that the emission of gamma rays is random.
- State the random nature of radioactive decay.
 - Describe what is meant by a gamma-ray
 - State two safety measures that the researcher must take.
 - Describe how the experiment is performed.
4. The nuclide notation for two isotopes of carbon is ${}_{6}\text{C}^{12}$ and ${}_{6}\text{C}^{14}$. Carbon-14 decays by beta emission to a stable isotope of nitrogen.
- Which nuclide of the carbon is? State with a reason.
 - Stable isotope
 - Radioisotope
 - What is meant by a beta particle?
 - Write the nuclear equation of carbon-14 decay to a nitrogen -14 by beta decay.
5. When a slow-moving neutron hits a ${}_{92}\text{U}^{235}$ nucleus, it splits into the nucleus of barium ${}_{56}\text{Ba}^{141}$ and the nucleus of krypton ${}_{36}\text{Kr}^{92}$ and emits three neutrons energy is released.
- $${}_{0}\text{n}^1 + {}_{92}\text{U}^{235} \rightarrow {}_{92}\text{U}^{236} \rightarrow {}_{56}\text{Ba}^{141} + {}_{36}\text{Kr}^{92} + 3 {}_{0}\text{n}^1 + \text{energy}$$
- State name of the nuclear process.
 - Which of the two isotopes of U-235 and U-236 have a shorter half-life.
 - How can we make radioisotopes artificially? Describe a suitable example
 - For the given process, state its one application in our daily lives.
6. The reaction that takes place at the center of the sun can be represented as
- $$2 {}_{1}\text{P}^1 + 2 {}_{0}\text{n}^1 \rightarrow {}_{2}\text{He}^4 + \text{energy}$$
- State the name of this type of reaction.
 - Also, define the reaction.
 - A Nuclear fusion reaction is a more reliable and sustainable energy source than nuclear fission chain reaction. Justify this statement with suitable arguments
7. a) What do you understand by the half-life of a radioactive element?



- b) When a Radium-226 undergoes alpha decay, Radon-222 is produced

$${}_{88}\text{Ra}^{226} \rightarrow {}_{86}\text{Rn}^{222} + {}_2\text{He}^4 + \text{energy}$$
 Which of the nuclide is a
 i. Parent nuclide
 ii. Daughter nuclide
- c) Define the terms
 i. Parent nuclide
 ii. Daughter nuclide
8. Describe uses of radioisotopes in
 a) medicine,
 b) industry,
 c) agriculture
9. a) What are the common radiation hazards?
 b) Why is an alpha source more harmful when lodged into the body?
 c) Which type of radiation is more hazardous than other radiations? Explain why?
 d) Describe briefly the safety measures that are taken against them.

Section (C) Numericals

1. A living plant contains approximately the same isotopic abundance of C-14 as does atmospheric carbon dioxide. The observed rate of decay of C-14 from a living plant is 15.3 disintegrations per minute per gram of carbon. How much disintegration per minute per gram of carbon will be measured from a 12900-year-old sample? (The half-life of C-14 is 5730 years.) **(2.2513, 0.21, 3.2)**
2. The smallest C-14 activity that can be measured is about 0.20%. If C-14 is used to date an object, the object must have died within how many years? **(51374 yr)**
3. How long will it take for 25% of the C-14 atoms in a sample of C-14 to decay? **(2378 yr)**
4. The carbon-14 decay rate of a sample obtained from a young tree is 0.296 disintegration per second per gram of the sample. Another wood sample prepared from an object recovered at an archaeological excavation gives a decay rate of 0.109 disintegration per second per gram of the sample. What is the age of the object? **(8258 yr)**



Glossary

AC Generators machine that converts mechanical energy into electrical energy like AC current.

Alpha Rays is a positively charged nuclear particle identical to the nucleus of a helium atom that consists of two protons and two neutrons.

Alternating Current is a type of electrical current, in which the direction of the flow of electrons switches back and forth at regular intervals or cycles.

Ammeter is a measuring instrument used to find the strength of the current flowing around an electrical circuit when connected in series with the part of the circuit being measured. A modified form of a galvanometer, connecting shunt (very small) resistance parallel to a galvanometer to make it an ammeter.

Amplitude: The maximum displacement from the mean position

Analogue Electronics: Analog means continuous and real. *Analog electronics* is a branch of electronics that deals with a continuously variable signal. It's widely used in radio and audio equipment along with other applications. The Analog signal translates the information into electric pulses of varying amplitude,

Artificial Radioactivity is produced in a substance by bombardment with high-speed particles (such as protons or neutrons).

Atom is the smallest building block of a matter.

Background Radiation: The measure of the level of ionizing radiation present in the environment. Most of the *background radiation* occurs naturally from minerals and a small fraction comes from man-made elements.

Beta Rays: Beta particles (β) are high-energy, high-speed electrons (β^-) or positrons (β^+) that are ejected from the nucleus by some radionuclides during a form of radioactive decay called beta-decay

Browsers: Applications that are used to access and view websites.

Capacitance: The ability to store electric charges its unit is Farad. $Q = CV$ OR $C = Q/V$

Capacitor: The electronic device that stores electric charges.

Cathode Rays emitted high-speed electrons in a stream from the heated cathode of a vacuum tube.

Cell Phone: A portable telephone that can make and receive calls over a radio frequency link while the user is moving within a telephone service area.

Central Process Unit (CPU) or (brain) of the Computer and it performs all types of data processing operations.

Compound Microscope is a high resolution and uses two sets of lenses to provide a 2-dimensional image of the sample.

Compression is a region in a longitudinal wave where the particles are closest together.

Computer: An electronic, that processes data according to a set of instructions.

Concave Lens is a lens that diverges the straight light coming from the source to create a reduced, upright, or digital picture. It can generate real and virtual objects, depending on the light source.

Concave Mirror is a spherical mirrors whose inner side is reflecting or polished.



Convex Lens (positive lens) is also known as a convergent lens. It can converge light rays passing parallel to its main axis.

Convex Mirror is a spherical mirror whose outer side is reflecting or polished.

Coulomb is the SI unit of electric charge, equal to the quantity of electricity conveyed in one second by a current of one ampere.

Crest: is the highest surface part of a wave is called the crest,

Critical Angle: is the angle of incidence, for which the angle of refraction is 90° . If light enters a denser medium from a comparatively rarer medium.

Damped Oscillation is that fades away with time. OR. The motion of an oscillator reduces due to an external force, the oscillator and its motion are damped.

Data: Collection of given information.

DC Motor is an electrical machine that converts electrical energy into mechanical energy. In a *DC motor*, the input electrical energy is the direct current.

Dielectric is very poor conductor of electric current. Dielectric means an insulator like Distilled water, transformer oil, etc. are liquid dielectric materials

Diffraction of waves involves a change in direction of waves as they pass through an opening or around a barrier in their path.

Digital Electronics: The branch of electronics that deals with the study of digital signals, and the components that use or create them. The digital signal translates information into a binary format of 0 and 1, where each bit represents two distinct amplitudes.

Direct Current is the flow of electric charge that does not change direction, or it is a unidirectional current. DC is produced by generators with commutators.

Dispersion of Light is process of splitting white light into its constituent colors.

Dispersion of light through Water Droplets: A rainbow is produced by dispersion and internal reflection of light in water droplets in the atmosphere.

Echo is the repetition of sound caused by the reflection of sound.

Electric Charge is the physical property of matter that causes it to experience a force when placed in an electromagnetic field. The charge may be positive or negative.

Electric Current is basically the flow of the electron per unit of time. Its unit is Amp (A). $I = q/t$

Electric Field Intensity at a point is the force experienced by a unit positive charge placed at that point. Electric Field Intensity is a vector quantity. $E = F/q$

Electric Field: The region around an electric charge.

Electric Potential is the amount of work needed to move a unit charge from a reference point to a specific point against an electric field. The unit of electric potential is volt. $V = \Delta w/q$

Electric Power: The rate at which a device changes current to another form of energy. $P = E/t$

Electrical Energy is a type of kinetic energy caused by moving electric charges. The amount of energy depends on the speed of the charges – the faster they move, carry more electrical energy.

Electrical Resistance is the *resistance* force that counter-acts the flow of current. Its unit is ohm.



Electricity is the form of energy, s that we get from the conversion of other sources of energy, like coal, natural gas, oil, nuclear power, and other natural sources, which are called primary sources.

Electromagnetic Force is a fundamental force. It is an interaction between electrically charged particles. It acts between charged particles and is associated with electric and magnetic fields. The electromagnetic force can be attractive or repulsive. $F = q(\mathbf{V} \times \mathbf{B})$ OR $F = BIL \sin \theta$

Electromagnetic Induction: The creation of an electro-motive force (EMF) by way of a moving magnetic field around an electric conductor and conversely, the creation of current by moving an electrical conductor through a static magnetic field.

Electromagnetic waves are created by a fusion of electric and magnetic fields. The light you see, and the colors around you are visible because of electromagnetic waves. These waves travel with a speed equal to the speed of light, i-e., 3×10^8 m/s. **Microwaves, X-rays, Radio waves, Ultraviolet waves, infrared, Visible rays, and Gamma rays.**

Electromagnetism is a type of magnetism produced by an electric current or The branch of Physics deals with the electromagnetic force that occurs between electrically charged particles.

Electromotive Force (emf) is the amount of energy required to drive a unit positive charge through an external circuit connected to a cell. its(emf) unit is joule per coulomb or volt.

Electron Gun: An electrical instrument produces a beam of electrons.

Electron is elementary particle having a negative charge, moving around the nucleus.

Electronics: The branch of physics and electrical engineering that deals with the emission, behavior, and effects of electrons and with electronic devices.

Electroscope is instrument used for detecting the presence of an electric charge.

Electrostatic Induction: A redistribution of electric charge in an object, caused by the influence of nearby charges.

Elements: An element is a substance that cannot be broken down into any other substance. An element is uniquely determined by the number of protons in the nuclei of its atoms.

Fax Machine: A device that sends and receives printed pages or images over telephone lines.

Frequency: The number of cycles in one second. $F = 1/T$

Gamma Rays: The part of the electromagnetic spectrum with the most energy and shortest wavelength. With no charge.

Glass Prism is a triangular object made up of a transparent material, like glass or plastic, that has at least two flat surfaces that form an acute angle

Half-life: The time needed for half of the material to decay. $T_{1/2} = \ln 2 / \lambda$

Hard Disk: Hard disk drive or hard drive, magnetic storage medium for a computer.

Hardware: The tangible or physical elements of a computer.

Image: The collection rays at a focal point when light rays appear to converge or to diverge after reflection or refraction is known as the *image*.

Information and Communication Technology: (ICT) is defined as a diverse set of technological tools and resources used to transmit, store, create, share, or exchange information.

Isotopes are atoms with the same number of protons but differ in numbers of neutrons. Isotopes are different forms of a single element.



Lens is basically glasses that are thicker/thinner with curved sides. A lens is a piece of transparent glass that concentrates or disperses light rays when passes through them by refraction.

Logic Gates: A device that acts as a building block for digital circuits. The basic logic gates are classified into seven types: AND gate, OR gate, XOR gate, NAND gate, NOR gate, XNOR gate, and NOT gate.

Longitudinal waves: The movement of the particles is parallel to the motion of the energy, i.e., the displacement of the medium is in the same direction in which the wave is moving. Example – Sound Waves, Pressure Waves

Magnetic Field is a vector field; it is the region around a magnetic material or a moving electric charge within which the force of magnetism acts. The unit of the magnetic field is Tesla (T).

Mechanical waves are a wave that is an oscillation of matter and is responsible for the transfer of energy through a medium.

Microscopy is the technical field to view samples & objects that cannot be seen by naked eye.

Moving Coil Galvanometer is electrical instrument used to measure a small amount of current.

Musical Sound has a pleasant effect on the listener.

Mutual Induction is process in which a changing current in one coil induces emf in another coil.

Natural Radioactivity is a phenomenon of spontaneous and continuous and uncontrollable disintegration of an unstable nucleus accompanied by the emission of active radiations is called natural radioactivity.

Neutron: Elementary particle not having any charge also lay in the nucleus.

Noise Pollution is unwanted and disturbing sounds in our environment.

Nuclear Fission: A nuclear reaction in which the nucleus of an atom splits into two or more nuclei.

Nuclear Fusion: A Nuclear reaction through which two or more light nuclei collide to form a heavier nucleus

Nuclear Transmutation: Nuclear transmutation is a conversion of one chemical element into another. A transmutation involves a change in the structure of atomic nuclei and hence may be brought by a nuclear reaction

Nucleus is in the center of an atom, containing proton and neutron in it.

Ohm's Law: The potential difference across conductors is directly proportional to the electric current flowing through it provided physical conditions same.

Oscilloscope is an instrument used to display and analyze the waveform of electronic signals.

Periodic Motion: A motion that repeats itself in an equal period of time.

Photo Phone is a device that allows transmission of speech on a beam of light.

Photographic Enlarger is an optical instrument used to enlarger image on a Photographic plate.

Potential Difference: is the difference in the amount of energy that charge carriers have between two points in a circuit. $V = \Delta W/Q$

Power Transformer is an electrical instrument used in transferring electrical power from one circuit to another without changing the frequency.

Primary Memory: The component of the computer that holds data, programs, and instructions that are currently in use. Primary storage is located on the motherboard.



Production of Sound Waves: It is produced from vibrating particles, so when there are no particles (i.e., there is no medium), sound cannot be generated, e.g. in outer space.

Projector is an apparatus with a system of lenses for projecting slides or film onto a screen.

Proton: Elementary particle having a positive charge, and lay in the nucleus

Quality of Sound or "timbre" is describes those characteristics of sound which allow the ear to distinguish sounds that have the same pitch and loudness

Radio waves: The wireless transmission and reception of electric signals by means of electromagnetic waves.

Radioactive Dating or Radiometric is a way to find out how old something is.

Radioisotopes: An unstable combination of neutrons and protons, or excess energy in their nucleus. When it breaks down becomes more stable

Rarefaction is a region in a longitudinal wave where the particles are furthest apart.

Reflection of Light: The bouncing back of the light.

Reflection of waves involves a change in direction of waves when they bounce off a barrier.

Refraction of Light is the change in direction of a wave passing from one medium to another is caused by its change in speed.

Refractive Index: The ratio of the velocity of light in a vacuum to its velocity in a specified medium. OR The ratio of incident angle to the refracted angle.

Refraction of waves: involves a change in the direction of waves as they pass from one medium to another.

Resistivity: The resistance per unit length and cross-sectional area is called resistivity. $R = \rho l/g$

Resistor is an instrument that limits or regulates the flow of electrical current in an electronic circuit

Secondary Storage devices: Any non-volatile storage device that is internal or external to the computer, such as floppy, USBs, CDs, or DVDs.

Self-Induction is the phenomenon in which a changing current in a coil induces an emf in itself.

Simple Harmonic Motion is an oscillatory motion under a retarding force directly proportional to the amount of displacement from an equilibrium position. Obeys Hook's law $F \propto -x$

Simple Microscope: it makes the image enlarged that cannot be seen by naked eyes.

Simple pendulum is an ideal pendulum consists of a point mass suspended by a weightless inextensible perfectly flexible thread and free to oscillate neglecting air resistance. $T = 2\pi\sqrt{l/g}$

Software is the set of instructions, data, programs used to operate and execute specific tasks.

Sound Waves: longitudinal (mechanical) is a wave of compression and rarefaction by which sound is propagated in an elastic medium such as air.

Spectrum: The intensity of light as it varies with wavelength or frequency.

Speed of Sound in (Gas, Liquid and Solids) varies from substance to substance: typically, sound travels most slowly in gases as compare to liquids and fastest in solids. For example, sound travels at 343 m/s in air, it travels at 1,481 m/s in water (almost 4.3 times as fast) and at 5,120 m/s in iron (almost 15 times as fast)

Speed of Sound is the distance traveled by sound wave per unit of time as it propagates through an elastic medium. At 20 °C (68 °F). $V = \lambda f$



Spherical Mirror is a mirror that has the shape of a piece cut out of a spherical surface. There are two types of spherical mirrors: concave, and convex.

Storage Devices: Used to store data.

Telescope: An arrangement of lenses, mirrors, or both that collects visible light, allowing direct observation or photographic recording of distant objects.

The internet: The internet is a globally connected network system facilitating worldwide communication and access to data resources.

The Spectrum of White Light is consisting of seven basic colors arranged in a specific order: red, orange, yellow, green, blue, indigo, and violet.

Thermionic Emission: Discharge of electrons from heated materials.

Time-Period: Time is taken by a wave to complete its one cycle or one oscillation.

$$T=1/f$$

to transmit or send data with the aid of an antenna.

Total Internal Reflection(TIR) is the complete reflection of a ray of light within a medium such as water or glass from the surrounding surfaces back into the medium. The phenomenon occurs if the angle of incidence is greater than the critical angle.

Transmitter: An electronic device used in telecommunications to produce radio waves

Transverse Waves- When the movement of the particles is at right angles or perpendicular to the motion of the energy, then this type of wave is known as a transverse wave. Light is an example of a transverse wave.

Trough is the lowest part is the trough.

Ultrasound is high-frequency wave. That a normal human ear cannot hear.

Voltmeter is an instrument used for measuring the potential difference between two points in an electrical circuit. A modified form of a galvanometer, connecting a large resistance in series with a galvanometer.

$$V \propto I \quad \text{OR} \quad V = IR \quad \text{OR} \quad I = V/R$$

Wave front is a surface over which the phase of the wave is constant

Wavelength is the spatial period of a periodic wave—the distance over which the wave's shape repeats.

$$\lambda = v/f$$

Waves is a dynamic disturbance of one or more quantities. Waves can be periodic. Waves transfer energy from one place to another, but they do not necessarily transfer any mass. Light, sound, and waves in the ocean are common examples of waves.

Wave-Speed: Distance travelled by wave travels in a unit time. $V = \lambda f$

